

Patchwork 3D Enterprise 2026 X8

USER MANUAL



TABLE OF CONTENTS

User manual for Patchwork 3D Enterprise	18
Patchwork 3D Overview	18
New Features in the 2026 X8 Version	20
Matter	20
Shaper	20
Required Hardware	21
64-bit Architectures	21
Minimal Configuration	21
Recommended Configuration	21
Getting Started	23
Connection to Community/Premium	23
Installing Patchwork 3D on a Computer User	23
Activating Patchwork 3D	24
Running Patchwork 3D for the First Time	24
License Activation Wizard	24
Requesting a Nodelock Activation for Your Computer	25
Using an Existing Nodelock Activation Key for Your Computer	25
Using a Floating Activation from an RLM License Server on Your Network	26
Using an activation with a license of tokens (dongle)	26
Overview	27
Importing Data	28
Actions in Shaper	28
Actions in Matter	28
Going Further	29
Interface Regions	29
Modules	30
Menus	30
Shaper Menus	30
Matter Menus	31
Toolbars	32
Workspace	32
Configuration Scheme	33
3D Viewport	36
Sidebar	36
Information Bar	37
Status bar	37
Editors	38
Context Menu	39
Lists	39
Items of a list or hierarchy	41
Data	42
P3D Database	42
Start Screen	45
Resources in a P3D File	46
Model	46
Product	47

Digital Aspect Mockup	47
Undo/Redo Mechanism	47
Shaper	48
Matter	48
Default Keyboard Shortcuts	48
Settings	53
General Tab	53
File Tab	54
User Interface (UI) Tab	56
Geometry Tab	58
Lighting Tab	58
Color Tab	60
Rendering Tab	60
OpenGL Engine Options	60
Raytracing Engine Options	61
User Preset Tab	61
Fresnel Value Presets	62
Snapshot Dimension Presets	63
Measurement Units	63
Shaper	65
Shaper Graphical Interface	65
Shaper Viewports	66
Configuring 3D Viewports	66
Interacting with the 3D Viewports	67
Configuring the Rendering in a 3D Viewport	68
Selection Visibility Modes	72
Manipulating Shaper Objects	72
Selection	72
Actions available from the context menu	73
Modifying the Selection Using Menu Operations	73
Surface Selector	73
Selection Mode	74
Manipulating Surfaces	76
Gizmos	76
Transformation Tools	78
Surface Visibility and Frozen States	79
Positioning Surfaces from the Main Interface	79
Coordinates in World Reference Frame	80
Coordinates Relative to Parent's Pivot	80
Relative Translation and Rotation	81
Applying a Transformation to a Selection of Surfaces	82
Defining the Step Values	82
Alignment tool	83
Aligning objects to a reference object	84
Aligning multiple objects to the leader object	85
Aligning multiple objects by selecting the leader object in the selection	87
Explode View Helper	87
Matter	90

Matter Graphical Interface	90
Collision Detection System	91
Matter Viewports	91
Importing an Object into the Active Viewport	92
Interacting with the 3D Viewports	92
Configuring the Rendering in a Viewport	94
Linking the Updates of the 3D Viewports	94
Grid and Axis Orientation	94
Render Statistics	95
Full Screen Mode	95
Floating Viewport of Matter	95
Modifying Default Properties	96
Unlinking from the Shaper Configuration	96
Viewport Rendering Modes	96
Managing Matter Resources	98
Dragging and Dropping Matter Resources	98
Purging Unused Matter Resources	99
Listing Matter Resources	99
Purging Unused GPU Resources	99
External Library Explorer	100
Editors	102
List of Editors in Patchwork 3D	102
Camera Animations (Editor)	106
Kam File Type	106
Bookmark Animator Type	107
Bézier Curve Path Type	109
Example: Creating a Rotor Animation	111
Backgrounds (Editor)	112
Unfolding & Stitch Workshop	114
Main Toolbar	116
2D UV Zone	118
Defining a Constraint	119
Modifying a Constraint	119
Releasing a Constraint	120
3D Geometry Zone	120
Edition zone	122
Unfolding tab	122
Stitches tab	127
Surface Cutting Workshop	130
Timelines (Editor)	135
Timeline Controls	136
Timeline Playback Controls	136
Navigation Controls for Timeline Tracks	137
Precise Positioning Controls	138
Timeline Library	138
Product Library	139
Camera Animations Library	139
Configuration Keys Library	140
Channel Clip Library	141

Texture Library	142
Aspect Layers (Editor)	143
Layer Tab	143
Bookmark Tab	146
Assignment Tab	146
Position Layers (Editor)	147
Cameras (Editor)	148
Camera List	148
Editing Camera Properties	150
Renaming the Camera	151
Choosing a Sensor	151
Lens	151
Channels (Editor)	154
Channel Selector	154
Standard Configuration	155
Using Preset Values for an Animated Mesh	156
Advanced Configuration	156
Sensors (Editor)	159
Snapshots (Editors)	160
Shared Settings	160
Dimensions of the Media Output	160
Rendering Engine	161
Files	162
Internal Render Info	165
Snapshot Process	166
Rendering Buttons	166
Specific Settings for Images	166
Dimensions Zone	166
Specific Settings for Videos	166
Dimensions Zone	167
Files Zone	167
Timeline Zone	169
Frame Output Zone	169
Preview	169
Specific Settings for Panoramas	170
Dimensions Box	170
Configuring the Codec	171
Timeline Zone	172
Frame Output Zone	172
Preview	172
Specific Settings for VR Objects	173
Preview Frame Zone	173
Camera Path Zone	174
VR Object Settings	174
Specific Settings for Cubic VR Panoramas	174
Configuration Keys (Editor)	175
Animation Sliders (Editor)	175
Animated Meshes	176
Translations	176
Rotations	176

Clips	176
Configurations (Editor)	176
Rule Tab	176
Browser Tab	177
Library Tab	178
Inspection Tab	178
GPU Consumption (Editor)	178
Running an Analysis	179
Summary of Consumption	179
Detection of Overconsumption	181
Rules	181
Colored Display	181
List of Results for All Surfaces	182
Results for a Picked Surface	182
Product Environments (Editor)	183
Environment Layers Tab	183
Environment Layers Box	183
Environments Box	184
Surfaces Using Environment Box	184
Product Environment Properties Tab	185
Environments Box	185
Orientation Box	185
Real-Time Sun Box	186
Environment's Brightest Point Box	186
Tag Manager	186
Using Tags to Create Configuration Triggers	187
Gradients (Editor)	188
Importing Gradient Ramps in .csv Format	189
RGB Profile	190
CIE Lab Profile	190
Flakes Color Editor	191
How to create a color palette?	192
How to import a color palette in CSV format?	192
Rendered Views History	192
Operations Toolbar	192
Engines Used for Rendering	193
Recalling a View	194
Text Image (Editor)	194
Operations Toolbar	194
Display Settings	195
Text	195
Preview	196
Materials (Editor)	196
Live Mode (Editor)	197
Defining Triggers	197
Creating a Trigger	198
Associating a Clip or a Timeline	199
Choosing a Play Mode	199
Configuration Browser	199
Measuring Tool	200

Snapshot Batcher	200
Snapshots Box	201
Selecting Snapshots	202
Snapshot Context Menu	203
Operations Toolbar	203
Adding and Modifying Snapshots Using the Snapshot Editors	203
Rendering from the Snapshot Batcher	204
Raytracing Settings (Editor)	204
Rendering	204
Adaptive Sampling	205
Denoiser	205
Ray Rebounds	206
Reflections	206
Transmissions	207
Clipping Planes (Editor)	208
General Settings for Clipping Planes	208
Settings for the Selected Plane	209
Creating a Contour	210
Additional Display Options	210
Post-Processing (Editor)	211
Advanced Menu	212
Database Properties (Editor)	214
Rendering Tab	214
Color Management Tab	214
Application Tab	214
Environment Properties (Editor)	214
General Properties	215
Parallax Correction	217
Box	217
Hemisphere	218
Local Environment Properties	218
Surface Properties (Shaper Editor)	218
Lighting	219
Geometry	219
Display	220
Properties of a Selection of Several Surfaces	221
Surface Properties (Matter Editor)	221
Visibility	221
Backface Culling	221
Depth Writing (Transparent Materials Only)	222
Transforming a Material	222
Product Properties (Editor)	223
Keyboard Map (Editor)	224
Actions	224
Navigation	225
Render Quality Settings (Editor)	225
Selections (Editor)	229
Saved Selections	229
Selection by type	230
Selection by lighting	230

Regular Expression Selections	230
Color Chooser (Editor)	231
Media	232
Color from Picker	232
Color from Temperature	233
Color from Color Books	234
Layer Visibility Bookmarks (Editor)	234
Real-Time Sun (Editor)	235
Sun Settings Box	236
Shadow Settings Box	237
North Setting Box	238
Position Box	239
Manual Tab	239
Date, Time and Location Tab	239
Extracted from Environment Tab	239
Raytracing Box	240
Overlays (Editor)	240
Textures (Editor)	241
Layer Visibility (Editor)	241
Modifying a Layer's Visibility	241
Modifying the Intensity and the Color of an Illumination Layer	242
Plug-ins	243
HDR Light Studio Plug-In	243
Import and Export	245
Importing 3D CAD Models	245
Import User Interface	246
General	247
Data	248
Scene orientation	248
Groups	248
Tessellation	249
Animations	249
Advanced options	250
Automatic scene preparation	250
Import Options	251
Exporting CAD models	253
P3DXml Format	254
FBX Import	254
Imported FBX Data	255
Surfaces	255
Point cache	255
Surface Parameterization	256
Materials	256
Textures	257
Camera Animation Path	257
Animation	258
Other FBX Nodes	258
Visibility Layer Hierarchy	258
Kinematic Hierarchy	258

Wire Import	259
Importing Files in the Wire Format	259
Geometry Data	259
Material Data	259
Wire File Format Import Options	260
Surfaces	260
Camera	261
Shaders	261
Topology Conversion Failures	261
Log	261
Update Mode	261
Exporting Matter Products	262
Export KDR	262
Export FBX	265
Models	266
Operations on Models	266
Surfaces	267
Operations on Surfaces	267
Surface Optimization	268
Triangulation	268
Stitch and Split Functions	269
Orientation: Front and Back Faces	269
Surface Auto-Orientation	270
Positioning Surfaces	274
Recalculating Normals	275
Surface States	276
Unfinished Surfaces	277
Marking a Surface as Unfinished	277
Finding Unfinished Surfaces	278
Surface groupings	278
Merge and unmerge surfaces	278
Create and delete a saved selection	279
Visual representation	280
Geometric Primitives	280
Plane Primitive	281
Box Primitive	281
Sphere Primitive	281
Hemisphere Primitive	282
Cylinder Primitive	282
Edit Primitive	282
Kinematic Primitives	283
Pivots	284
Operations on Pivots	284
UV Mapping	286
Assigning Mapping	286
Mapping Operators	287
Extraction	287

Planar Projection	288
Box Projection	288
Open Box Projection	288
Spherical Projection	289
Cylindrical Projection	289
Cylindrical with Cap Projection	289
Transforming Mapping Gizmos	290
UV mapping scaling	290
Repetition on the U and U Axis	290
Automatic Alignment	290
Viewing the Mapping Information	291
Kinematics	292
Modifying the Hierarchy	293
Saving the Hierarchy	293
Kinematic Properties of Hierarchy Parts	294
Properties of Rotating Parts	294
Properties of Translatable Parts	294
Properties of Freely Transformable Parts	294
List of Objects Belonging to Parts	295
Assigning Objects to a Parent Part	295
Assignment Modes	295
Keeps Child's World Position	295
Aligns to Parent-Relative Position	296
Repositioning Parts and Their Associated Objects	296
Animation Constraints	296
Managing the List of Constraints	297
Position Constraints	297
Orientation Constraints	297
Look At Constraints	297
Follow Path Constraints	298
Lighting	299
Type of illumination rendering	299
Preview Mode	300
Calculating Lightmaps	300
Filtering Layers	300
Filtering Surfaces	301
Setting the Render Quality	301
Launching a Lightmap Render	301
Options for Existing Lightmaps	302
Light Sources	302
Light Source Groups	303
Properties common to all types of source	303
Adjusting the Light Source's Properties	304
Positioning Light Sources	306
Properties of Sky Sources	308
Properties of Spot Sources	308
Gizmos for Aperture and Attenuation Cones	308
Properties of Sun Sources	309
Properties of Omni Sources	310

Properties of Area Sources	310
Lighting Planner	311
Planning a Lighting Sequence	311
Lighting Layer	312
Configuration	312
Part Animator	312
Selected Surfaces	312
Distributed Lightmap Rendering	314
Patchwork Lightmap Render	314
Installing Patchwork Lightmap Render	314
How Patchwork Lightmap Render Machines Work ?	314
Distributed Lightmap Rendering Mode in Patchwork 3D	315
Setting up the Distributed Rendering	315
Starting a Distributed Rendering	316
Stopping Distributed Rendering	317
Resources Consumed	318
Behavior Following Loss of Connection	319
Loss of Network Connection	319
Patchwork 3D Crash	319
Products	320
Product Library	320
Product Properties	320
Surface Visibility	320
Environment	320
Background	321
Standard Assignment	321
Background and Environment on Product Selection	321
Materials	323
Material Library	323
AxF Material	326
Standard Material	326
Basic Principles	327
Diffuse	328
Diffuse Color	328
Color Map	329
Transparency of the Diffuse Layer	331
Filter According to View Angle	332
Reflection	332
Intensity	333
Color Filter	333
Specular Map	334
Roughness	335
Diffuse Filter	337
Transparent Filter	337
Bump	338
Enhanced Relief	339
Sticker	341
Raytracing	341

Environment Material	341
Environment material lighting behavior	342
Principle	342
When to use it?	342
Apply a lighting mode to the scene	343
Media	344
Using an Alternate Background Texture as an Environment Material	344
Matte Material	345
Mirror Material	345
Diffuse	346
Diffuse Color	346
Color Map	347
Transparency of the Diffuse Layer	349
Reflection	351
Reflection color	352
Specular Map	352
Roughness	353
Media	354
Bump	354
Multilayer Materials	356
Types of Layers: Diffuse Layer	356
Types of Layers: Specular Layer	357
Types of Layers: Illumination Layer	357
Flakes layer	358
Enhanced Relief	360
Enabling Enhanced Relief	360
Settings	360
Seam Material	361
Diffuse	362
Reflection	362
Bump	362
Sticker Material	363
Managing Applied Stickers	364
Assigning a Material to a Surface	364
Assigning Materials as Stickers	365
Positioning and Orienting Materials	366
Lighting Environments	367
Environment Library	368
Manipulating the Environment	371
Manipulating the Environment from Editors	371
Examples of Environments with a Product	371
Local Environments	372
Setting Local Environment Parameters	372
Multiple Environments	374
Textures	376
Texture Library	376
Use text as texture	379
Use video textures	379
Use animated textures	379

Backgrounds	381
Assignment	381
Background Library	381
Overlays	384
Enabling Overlays	384
Overlays in Configurations	384
Overlays in Animations	384
Overlay Library	385
How to Make an Overlay	387
Examples	387
Post-Processing	389
Enabling Post-Processing	389
Post-Processing Effects	389
Post-Processing Library	392
Tone Mapping	394
PBR Neutral Tone Mapping	395
Principle	395
When to use it?	395
Creating and applying an effect	395
Reinhard Tone Mapping	396
Drago Tone Mapping	397
Sensors	400
Default Values	400
Attributing a New Sensor to a Viewport's Free Camera	400
Sensor Library	400
Using Sensors	402
Opening a Database from an Older Version	402
Assigning a Sensor to a Camera	402
Assigning a Sensor to a Viewport	403
Modifying the Sensor Used in a Viewport	403
Geometry Layers	404
Operations on Geometry Layers	404
Position Layers	406
Definition	406
Displaying Position Layers	406
Lighting Layers	407
Operations on Lighting Layers	407
Using Lighting Layers	408
Substitution	409
Configuration	409
Recommendations	409
Settings for a Lighting Layer	409
Environment Layers	411
Using Environment Layers	411

Aspect Layers	413
Accessing All Aspect Layers with Assignments	413
Moving Material and Sticker Assignments	413
Live Mode	414
Product Configurations	415
Definitions used in Configurations	415
Preparing a Model	416
Understanding Partitions	417
Using Meaningful Layer Names	417
Configuration Rules	418
Definition of a Rule	418
Understanding Functional Principles of Symbols	418
Activation/Deactivation Principle: "partition" Symbols	419
Exclusion Principle: "partition.value_n" Symbols	419
Creating Simple Rules	420
Creating Simple Rules by Dragging and Dropping	420
Adding Targets to Existing Rules by Dragging and Dropping	424
Creating Simple Rules Manually	424
Creating Complex Rules	426
Rule Syntax	428
Simple Rules	428
Complex Rules	429
Example: Creating Configuration Rules	429
Configuration Annex: Auto-Partitioning	435
The Concept of Auto-Partitioning Aspect Layers	435
Example: Creating a Configured Product with Auto-Partitioning	436
Step 1: Creation of a Blank Product and Layers Import from All Product Versions	437
Step 2: Auto-Partitioning	438
Step 3: Renaming the Layers	439
Step 4: Rule Creation	440
Cameras	441
Identifying the Camera Used in a Viewport	441
Recalling a Camera's Settings in a Viewport	442
Modifying a Camera's Settings	442
By directly selecting a camera in the viewport	442
By selecting a camera from the Cameras list	443
Default Camera: the Free Camera	443
Viewport Free Camera	443
Viewport Camera Presets	444
Product Favorite Cameras	444
Generating Bookmarks from a Kam File	445
To load a *.kam file:	445
To generate the bookmarks:	445
Animation	447
Animating Geometries	447
Animation Utility Objects	448
Null	448

Rotation Axis	448
Translation Vector	449
Timelines	449
Items in Tracks: Clips and Keys	450
Selecting Individual Items	450
Selecting Multiple Items	451
Repositioning Items	451
Resizing Clips	451
Loop, Reverse, and Delete Elements	452
Bézier Curve Primitives	452
Modifying a Bézier Curve	453
Modifying a Bézier Curve via the contextual menu	453
Modifying a Bézier Curve via the editor	454
Bézier Curve Position and Orientation	455
Live Mode	456
Animating Channels with Advanced Configuration	457
Clipping Planes	459
Animating Clipping Planes	459
Real-Time Sun	460
Antialiasing	461
Enhanced Transparency	462
Enabling Enhanced Transparency	462
Standard versus Enhanced Transparency	462
Raytracing	464
Ray tracing a View	464
Ray tracing a view	464
Path tracing a view	465
Creating Snapshots using the Ray tracing engine	465
Rendering Snapshots, Videos, and 3D Environments	467
Snapshot Menu	467
Printing	468
General Print Window	468
Printing to a File	468
Scripting	470
Workspaces	470
About	471
About Lumiscaphe	471
About This Documentation	471
Interface Text	471
Links	472
Boxes	472
Step-by-Step Instructions	472
Images of the Interface	472

Version: 20260626.0534

© Lumiscoppe SA, 2001-2026

Headquarters:

ZA du Courneau II
8, impasse de la rouilleuse
33610 Canéjan
France

Documentation lead: P. Peyrevidal

Reproduction, extraction, presentation, alteration, modification, or use, whether in whole or in part, of this documentation or any of its elements whatsoever, by whatever means or for whatever purpose, and more generally any act that has not been explicitly authorized by Lumiscoppe, are strictly forbidden and subject to prosecution.

Trademarks, brands, brand names, service marks, logos, and other distinctive symbols displayed in this documentation are the property of their respective owners. They are protected by French and European legislation, as well as by other applicable legislation. All unauthorized use or reproduction is strictly prohibited.

This software uses NVIDIA® Iray® technology. Iray® 2022.1.0

This software uses X-Rite AxF™ technology.

This software uses components from Siemens Digital Industries Software. Copyright 2019-2021. All Rights Reserved.

This software uses components from 3DS Spatial Corp. Copyright 1986-2021. All Rights Reserved.

This software uses libHaru 2.0.8. More info at libharu.org.

This software uses UMFPACK Version 5.1. Copyright 1994-2021 by Timothy A. Davis, University of Florida. All Rights Reserved. More info at faculty.cse.tamu.edu/davis/suitesparse.html.

This software contains Autodesk™ FBX™ code developed by Autodesk, Inc. Copyright 2011 Autodesk, Inc. All rights, reserved. Such code is provided "as is" and Autodesk, Inc. disclaims any and all warranties, whether express or implied, including without limitation the implied warranties of merchantability, fitness for a particular purpose, or non-infringement of third-party rights. In no event shall Autodesk, Inc. be liable for any direct, indirect, incidental, special, exemplary, or consequential damages (including, but not limited to, procurement of substitute goods or services; loss of use, data, or profits; or business interruption) however caused and on any theory of liability, whether in contract, strict liability, or tort (including negligence or otherwise) arising in any way out of such code.

This software uses Little CMS 2.9.0-a. Copyright 1998-2021 Marti Maria Saguer. More info at www.littlecms.com. Little CMS is used under the MIT license.

This software uses the FreedImage open-source image library. More info at freeimage.sourceforge.io. FreedImage is used under the FIPL, version 1.0.

This software uses the GLEW open-source library. More info at glew.sourceforge.net. GLEW is under the Mesa 3-D License (MIT License)

This software uses libav 13 (see LGPL 2.1). More info at [libav](#).

This software uses lib3ds 2.0.0 (see LGPL 2.1). More info at [lib3ds](#).

The Libav library under Lesser General Public License (LGPL 2.1) and its source code can [be downloaded here](#).

The lib3ds library under Lesser General Public License (LGPL 2.1) and its source code can [be downloaded here](#).

This software uses the FreeType library. More info at www.freetype.org. FreeType is under the FreeType License (BSD-style License)

Information about the LGPL 2.1 license can be found in the LGPL folder.

This software uses Embree. Copyright 2009-2021 Intel Corporation. More info at <http://software.intel.com/en-us/articles/embree-photo-realistic-ray-tracing-kernels/>. Embree is used under the Apache v2.0 license.

This software uses Threading Building Blocks (TBB). Copyright 2005-2021 Intel Corporation. More info at <https://www.threadingbuildingblocks.org>. TBB is used under the Apache v2.0 license.

This product is licensed under the AVC patent portfolio license for the personal use of a consumer or other uses in which it does not receive remuneration to (i) encode video in compliance with the AVC standard ("AVC VIDEO") and/or (ii) decode AVC video that was encoded by a consumer engaged in personal activity and/or was obtained from a video provider licensed to provide AVC video. No license is granted or shall be implied for any other use. Additional information may be obtained from MPEG LA, L.L.C. See <http://www.mpegla.com>

This documentation is provided with the software Patchwork 3D Enterprise. It does not, however, constitute a contractual agreement regarding the features and functionality of the software.

USER MANUAL FOR PATCHWORK 3D ENTERPRISE

This manual describes the features of Patchwork 3D Enterprise 2026 X8 and their use, provides step-by-step procedures and recommendations, and introduces the conventions for reading documentation.

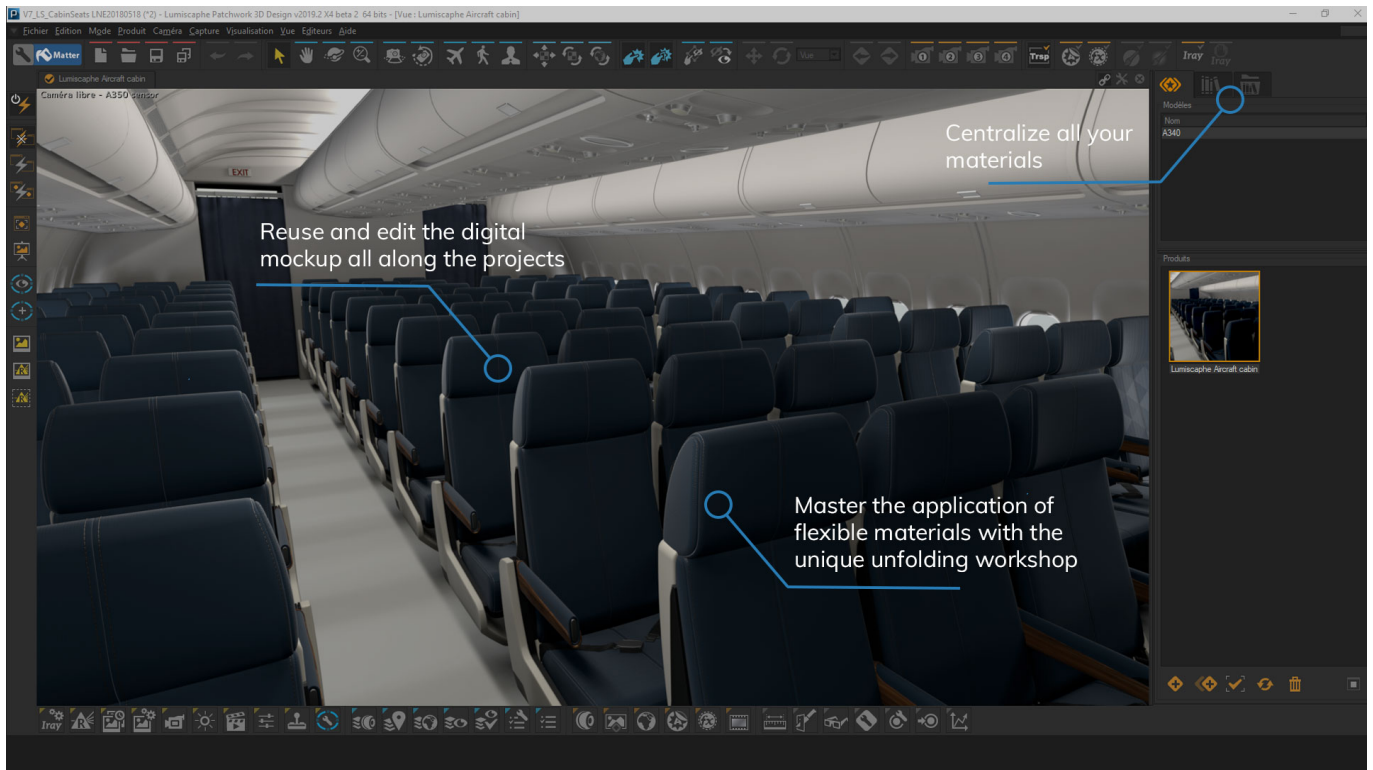

For a detailed explanation of how this documentation works and is organized, see [About This Documentation \[471\]](#).

Patchwork 3D Overview

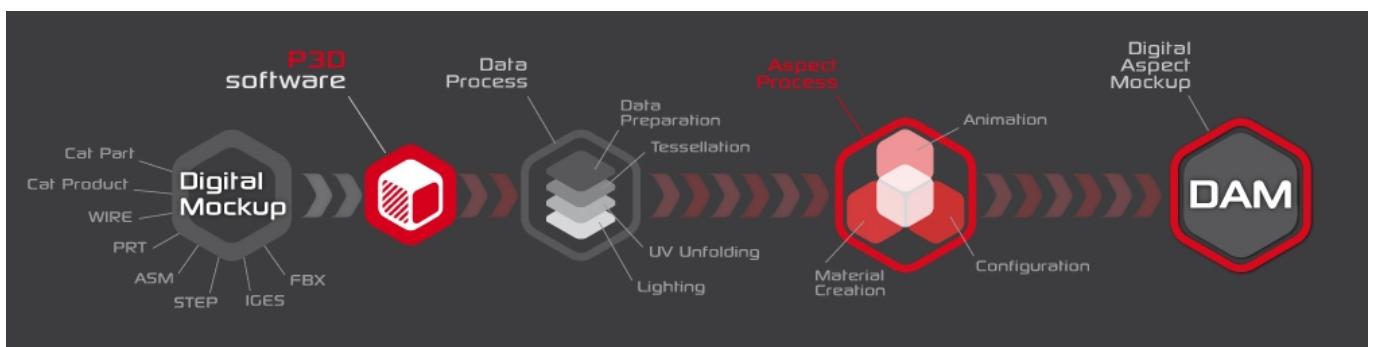

Lumiscaphe's Patchwork 3D software suite enables organizations to convert their original CAD data to Digital Aspect Mockups (DAMs) or to static images and dynamic renderings while maintaining complete in-house control over the process. Permanent data access is assured through local storage or through a Product Lifecycle Management system (PLM).

Patchwork 3D Enterprise

Patchwork 3D Enterprise is a complete DAM production tool built to meet the needs of the design.

Used for product development during the design phases, Patchwork 3D Enterprise provides a range of effective tools for working in real time on the style, colors and materials of the product.

Patchwork 3D Community & Premium

Patchwork 3D Community is a full software and free to use for non-commercial use.

It is particularly suited for:

- people who need to evaluate the software on a longer period than the three weeks of Enterprise evaluation license.
- for students and trainers to learn by themselves without or before contracting our Education program, Lumi'School.
- for graduates and former Enterprise Users searching for a job.
- freelancers and users of small businesses, who need to advise customers or bosses.

For assistance, use the [patchwork3d.com public forum](https://patchwork3d.com/public/forum). You will find there tips and tricks that will help you. Stay tuned by subscribing to the newsletter or following us on [Youtube](#) and [Twitter](#).

Patchwork 3D Premium, for its part, is intended for commercial use. You must acquire a Patchwork 3D Premium license to use it.

Patchwork 3D Engineering

Through its synchronization of the DAM with the PLM system during the entire product lifecycle, Patchwork 3D Engineering is particularly suited for perceived quality reviews and for the production of marketing imagery.

NEW FEATURES IN THE 2026 X8 VERSION

Matter

- Addition of the [Configuration Scheme workspace](#) to streamline and automate product configuration creation [33].
- Increase the [number of samples](#) to 512 for the roughness of the [Mirror material reflection](#) [353] to reduce noise during rendering.

Shaper

- Improvement of the [Lighting](#) [303] tab with a reorganized and more readable interface.

REQUIRED HARDWARE



NOTICE

The hardware described below may not be compatible with your software edition: Community, Premium, Essential, or Enterprise.

64-bit Architectures

Patchwork 3D Enterprise runs on 64-bit architectures.

Minimal Configuration

Operating system: Windows 10 x64 or newer.

Processor: Intel Pentium Core i5 Sandy Bridge or higher, AMD Athlon II X4 or higher.

RAM: 8 GB, 16 GB for raytracing.

Workstation	Laptop
Quadro M6000 (12 GB)	Quadro M5100M (8 GB)
Quadro M5000 (8 GB)	Quadro M5000M (8 GB)
Quadro M4000 (8 GB)	Quadro M4000M (4 GB)
	Quadro M2000M (4 GB)



NOTE

Graphics cards must be used with the latest certified NVIDIA® drivers.

The minimum version of the NVIDIA driver supported by Patchwork 3D Enterprise 2026 is the **570**.

The minimum supported graphics cards are NVIDIA Quadro **Maxwell** generation.

Recommended Configuration

Operating system: Windows 11 x64 or newer.

Processor: Intel Core i7 Haswell or higher, AMD Bulldozer or higher.

RAM: 16 GB, 24 GB for raytracing with large scenes, and processor with at least 8 cores.

Workstation	Laptop
RTX A6000 (48 GB)	RTX A5500 (16 GB)
RTX A6000 (24 GB)	RTX A5000 (16 GB)
RTX A5000 (24 GB)	RTX A4500 (20 GB)
RTX A5500 (24 GB)	RTX A4000 (16 GB)
RTX A4500 (20 GB)	RTX A3000 (12 GB)
RTX A4000 (16 GB)	
RTX A2000 (12 GB)	
RTX A2000 (6 GB)	
Quadro RTX 8000 (48 GB)	Quadro RTX 3000 (6 GB)
Quadro RTX 6000 (24 GB)	
Quadro RTX 5000 (16 GB)	
Quadro RTX 4000 (8 GB)	
Quadro GV100 (32 GB)	-
Quadro GP100 (16 GB)	
Quadro P4000 (8 GB)	-



NOTE

Graphics cards must be used with the latest certified NVIDIA® drivers.

We recommend using NVIDIA Quadro RTX cards from the **Turing** generation.

GETTING STARTED

Connection to Community/Premium

To use Patchwork 3D Community/Premium you need to log in to your Lumiscaphe user account.

At first launch, the software loads a web page in your favorite web browser to identify yourself.

Two choices are available:

- Create a new account by entering your **Email**, your **Password** and click the **Register** button.
- Enter your **Email**, your **Password** et click the **Submit** button to log in.



TIP

Good to know:

Patchwork 3D Community/Premium can be used for up to 3 days offline.

You have to log in every 30 days.

You can disconnect Patchwork 3D Community/Premium from your user account to prevent using under your identity, as on a shared computer for example. To do this, click **File > Log out and Quit**.

The user can check his current license rights period in the software activation information window, accessible in the menu **Help > License activation**.

Installing Patchwork 3D on a Computer User

This process installs Patchwork 3D on a location of your choosing. It creates a listing in the **Start menu > Programs > Lumiscaphe** folder and places a shortcut icon on the desktop.

You will need:

- Administrator privileges on the computer where you intend to install Patchwork 3D.
- The software's .msi installation file.

We strongly advise running the .msi executable file locally, that is, saving it to the computer you wish to install the software on before running it. You can place it on the desktop or in any other folder on your computer.

1. Run the .msi executable file for Patchwork 3D by double-clicking on it. Unless you have deactivated alerts, Windows will ask if you want to execute this file. Click the **Execute** button.

2. A wizard will guide you through the following steps of the installation.
 - a. Computation of space requirements. The installer will verify that there is enough space on your hard drive to install the software. Once this automated step is complete, you will be asked to click **Next** in order to proceed.
 - b. Presentation of the end user license agreement. Read the end user license agreement carefully. You must accept the terms of this contract and check the box **I accept the terms of the license agreement** in order to continue with the installation. At this point, you also have the opportunity to print the license agreement. Click on **Next** to continue.
 - c. Choice of destination folder. By default, the installation wizard will install Patchwork 3D in the following folder:

C:\Program Files\Lumiscaphe\Patchwork 3D 2026 X8 release 1\

If you would like to install it elsewhere on your computer, click the **Change...** button and select or create a new folder for the installation. If you know the directory path of the folder you would like to use, you may also type it in. Click **Next** to continue.

- d. Validation. Click **Install** to continue or, if you want to make changes in the previous steps, click **Back**. You can also cancel the installation by clicking on the **Cancel** button.
- e. Installation. A status bar keeps you informed of the progress of the installation. When the installation is complete, click **Finish** to close the installation wizard.

Activating Patchwork 3D

Running Patchwork 3D for the First Time

The first time you run Patchwork 3D by selecting it from the **Start** menu > **Programs** > **Lumiscaphe** or by double-clicking on the icon on your desktop, the activation wizard will open automatically. You are required to activate Patchwork 3D before first use.

In order to complete the activation of your software, you will need a license. The following procedures will walk you through the steps to activate your software, including the steps to obtain your license key.

Follow the steps below or contact us at license@lumiscaphe.com (<license@lumiscaphe.com>) for further assistance.

To purchase a license or to obtain an evaluation copy of Patchwork 3D, the sales team is at your disposal. You can reach us at sales@lumiscaphe.com (<sales@lumiscaphe.com>).

License Activation Wizard



NOTE

The activation wizard will run when you open Patchwork 3D for the first time. You can also run it yourself at any time from the **Help** menu > **License Activation** > **Restart wizard...** button.

An activation wizard will guide you through the steps to activate Patchwork 3D.

First, choose your activation method. Four options are listed: two for nodelock licenses, and one for floating licenses, and one for dongles with tokens.

Choose one of the following options:

- **Create an activation request ;**
- **Activate the product with a license file ;**
- **Activate the product with a server on the network ;**
- **Activate the software with a token license (USB key).**

Requesting a Nodelock Activation for Your Computer

Choose this method if you don't have a license activation key yet but have already purchased your license.

1. Select ***I need activation for this computer*** on the first screen of the activation wizard, then ***click Next>.>***
2. Provide the account information requested by the activation wizard on the next screen. You will be asked for your name, your company, and your email address. You must provide your company email. This allows us to identify you. We will send the license key you request to the company email address you provide in this step.
3. Click the ***Save File...*** button. Choose where this file will be saved. It is advisable to save it in an easy to find place, for example, the office. By default, the name of the file is presented as follows: "20150315_Votre Société_Request_disksn = WD-WMAYUM849339.lar". Do not change the name of this file.
4. Click on ***Finish*** to close the wizard.
5. Email the file you have created to <license@lumiscaphe.com>.
6. When we receive this file, we will send you your activation key. Once you have received your activation key, you can run your P3D software again. This time choose ***I already have an activation file for this computer*** when the activation wizard opens. (See paragraph below [25].)

Using an Existing Nodelock Activation Key for Your Computer

Choose this method if you have already received a license activation key. These are files ending with extensions .lic or .klic. Choose the option I already have an activation file for this computer to use the license activation file you received attached to the email with the download links. This file must be saved to your computer.

1. Select ***I already have an activation file for this computer*** on the first screen of the activation wizard. Then, click ***Next >***.
2. Click on ***Select a license file...*** A window in which you can navigate to find your license activation key file opens. Select this file, then click ***Open***.
3. Click on ***Next>*** .
4. Your activation is complete. Click ***Finish*** to launch Patchwork 3D.

We recommend moving your .lic or .klic file to the following directory for safekeeping:

C:\Users\[Your User]\Documents\Lumiscaphe\Patchwork 3D Design 2026 X8\

This file will be useful in the future if you need to reactivate Patchwork 3D. It can also be used to provide us with information in the case of a problem with your activation, whether now or later on.

Using a Floating Activation from an RLM License Server on Your Network

Choose this method if you have purchased a floating license and have installed it on an RLM license server. Your computer must be connected to this server by a network. Currently, this method should be used for all floating licenses for Patchwork 3D.

1. Select ***I want to use an activation from an RLM license server on my network*** on the first screen of the activation wizard. Then, click **Next >**.
2. Enter the name of the RLM license server in the text box. If you do not know the name of your RLM license server, ask your system administrator. Click the **Next >** button.
3. Your activation is complete. Click on **Finish**.
4. On the next screen, all of the licenses available on your server will be listed.

Click on the license ID you want to use. If you only have one license ID available, or if you always want to use the same license ID, you can also tick the checkbox for the option ***Always use selected license***. If you do not check this option, you will be asked to select your license ID every time you open Patchwork 3D.

Then click **OK** to start Patchwork 3D.

Using an activation with a license of tokens (dongle)

Choose this option if you have a UniKey dongle (USB key) to use Patchwork 3D occasionally. Indeed, the activation of a license token per USB key is valid for 24 hours from the moment of acquisition of the token



NOTE

Once the license token is activated, it is not necessary to let the USB key (dongle) plugged into your computer. The token remains valid until the 24-hour period is over. When the token is no longer valid, it is necessary to plug the USB key back in to use another one token.

1. There are two possibilities of activation:
 - Via the dongle which is connected to the computer,
 - Via a server or via a network. In this case, it is possible to indicate the IP address of the server in the dedicated field (speeds up the search for the server). If the specified server is not available, it is possible to automatically search for a server on the local network by checking the box
2. Once you have made your choice, click on **Next >** and the wizard will confirm that the activation has been completed.

3. Click on **Finish**.
4. Patchwork 3D will prompt you to use a new token.



Overview

In the next pages, you will discover the structure of the [user interface \[29\]](#), the way Patchwork 3D organizes the [data \[42\]](#), and the [preferences \[53\]](#) of the software, including the default [shortcuts \[48\]](#). This will help you orient yourself in Patchwork 3D.



You will also need to know how to [manipulate objects \[72\]](#) and how [to navigate in a 3D view \[66\]](#).

Manipulating objects and navigating in viewports in a nutshell

Manipulating objects in **Shaper**:

-  **Translation gizmo**: use this to move an object along an axis or on a plane.
-  **Rotation Gizmo** : use this to rotate an object in 3D space.

Viewport navigation:

-  Middle mouse button: hold and drag to pan.
-  **Ctrl** + middle mouse button: hold and drag to orbit (turn the view in all directions).
-  **Shift** + **Ctrl** + middle mouse button: keep pressed and move the mouse to zoom.
- **Ctrl** + **Space**: recenter the camera by placing the surface point under the cursor at the center of the viewport.

Depending on how Patchwork 3D fits into your workflow, you might be starting from scratch with a CAD file. Below there is an example of a process that you can use.

The Patchwork 3D Workflow in a nutshell

In **Shaper**:

1. Import a CAD file to obtain a model.
2. Optimize the imported CAD data.
3. Add mapping, kinematics, and lighting.

In **Matter**:

1. Create and assign materials.
2. Develop a rich setting.
3. Add animation.
4. Render high-definition, photorealistic images, videos, and viewer-readable files.

Importing Data

Here are a few suggestions on how to start:

- If you have a CAD file, [import it \[245\]](#) to create the first 3D Patchwork model.
- If you do not have a CAD file, it is possible to explore the functions of Patchwork 3D by creating a simplified model with the [geometric primitives \[280\]](#) generated directly by the software.
- If you have a Patchwork 3D database, it will likely already contain a model.

Actions in Shaper

Here are some things to do in the **Shaper** module once you've imported your data:

- [Move surfaces in the 3D \[267\]](#) world to position or orient them differently,
- [Duplicate a surface \[267\]](#) or duplicate a surface with symmetry,
- [Move a surface to a different geometry layer \[267\]](#) ;
- [Adjust the tessellation \[268\]](#) of a surface,
- [Modify a surface's UV mapping \[286\]](#),
- [Parent a surface to a kinematic object \[292\]](#) for animation,
- [Add lighting to your model \[299\]](#).

Usually, you'll have finished with the geometry-related tasks in the **Shaper** module before switching to the **Matter** module to dress your model, but you may find yourself switching back and forth for certain tasks.

Actions in Matter

In **Matter**, dressing a model can include tasks like the following:

- [Create a product \[320\]](#) and open it in a [viewport \[91\]](#),
- [Create a material \[196\]](#) and [apply it to a surface \[364\]](#) of your product,
- [Import a texture \[376\]](#) and use it as a background, as relief or as a pattern in a material,
- Use materials to create the [shadow \[345\]](#) of your product,
- Use materials to create [reflective or transparent surfaces \[345\]](#),
- Add a [lighting environment \[367\]](#),
- Use a lighting environment as [a visual on a skydome \[341\]](#),
- Set up points of view using [cameras \[441\]](#),
- Add [backgrounds \[381\]](#), [overlays \[384\]](#), and [2D post-processing \[389\]](#);
- Add [configurability \[415\]](#) to your product:
 - Create [geometry \[404\]](#), [position \[406\]](#), [lighting \[407\]](#), [environment \[411\]](#), and [aspect layers \[413\]](#),
 - Create [configuration rules \[420\]](#) that impose the conditions under which each layer should be displayed,
 - Save combinations of rule states (and, consequently, layer combinations) as [configuration bookmarks \[178\]](#).
- Add a [real-time light \[235\]](#) to your product,
- [Animate \[447\]](#) the product;
- Render with [raytracing \[204\]](#) for true-to-life distortions wherever light is reflected or refracted,
- Generate [high-definition images \[166\]](#) or [videos \[166\]](#);
- [Export \[262\]](#) a product for use in viewers and other Lumiscaphe satellite applications.

Going Further

These are just ideas that skim the surface of the functions of Patchwork 3D. As you explore, you'll find additional functions and specific settings that allow you to obtain the exact results you are aiming for. Most of these functions and controls are described in the rest of this documentation.



TIP

For additional help, you can also contact our support department at support@lumiscaphe.com or set up a personalized training session through your account manager at sales@lumiscaphe.com.

Interface Regions

The interface of Patchwork 3D is composed of several main regions where you can find tools and information.

Modules

Patchwork 3D consists of two modules, each with its own interface: **Shaper** and **Matter**. **Shaper** combines all the tools for working on the 3D models. **Matter** combines all the tools for creating materials, dressing the models interactively and calculating high-definition images.

Only one of the two modules is active at any given time. The toggle button **Shaper / Matter**, visible in the toolbar under the menu **File**, allows you to switch from module **Shaper** to the module **Matter** and vice versa.

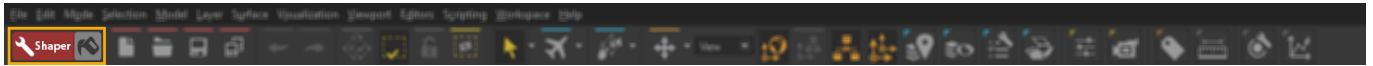

The toggle button. You are currently working in Shaper. Click here to switch to the Matter interface.



The toggle button. You are currently working in Matter. Click here to switch to the Shaper interface.

Menus

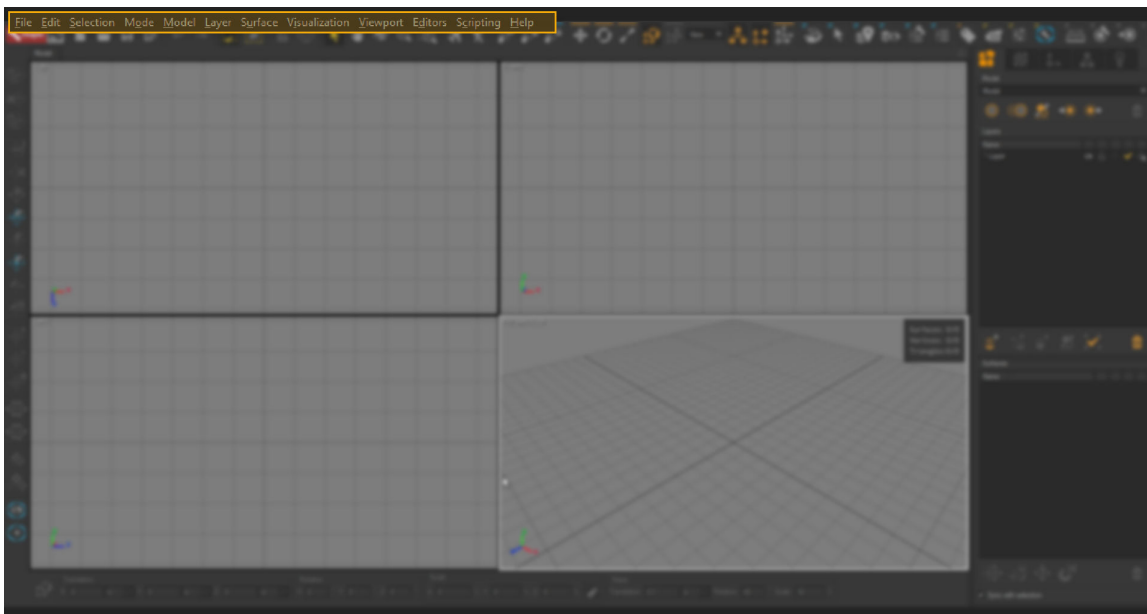

Menus allow you to handle the application: set your preferences, manage the operations stored in memory, open, save, and close databases.

The menus are organized according to the element your actions will affect; in the corresponding menu, you will find the main actions for each of these elements.

Shaper Menus

File: provides the options concerning the software or the database, including access to program settings and to the set-up of the program shortcuts.

Edit: offers access to the undo / redo options and to the selection options.

Mode: gives access to the various interface interaction modes.

Model: collects the options regarding models, including the functions for creating surfaces that make up a model, as well as imports and exports.

Layer: offers various actions to be performed on layers, for example, showing / hiding them or freezing / unfreezing them.

Surface: groups together the functions concerning surfaces.

Visualization: offers access to the visualization options, including the head up display, antialiasing, grid and axis orientation, as well as the visibility/non-visibility options for the current selection.

Viewport: allows the display windows called "viewports" to be manipulated.

Editors: gives access to the different editors available.

Scripting: gives access to the different scripting modes.

Workspace: allows you to change the Patchwork 3D user interface by reordering the toolbars according to your uses. Each reorders of toolbars can be saved in a workspace.

Help: gives access to the help and information files.

Matter Menus

File: provides the options concerning the software or the database, including access to program settings and to the set-up of the program shortcuts.

Edit: offers access to the undo / redo options and to the options to purge resources currently stored in memory.

Mode: gives access to the various interface interaction modes.

Product: groups together the options concerning products, including their export.

Camera: contains functions related to cameras and to sensors.

Snapshot: provides access to the snapshot tools.

Visualization: offers access to the visualization options, including the grid and axis orientation, as well as the stereoscopy options and the full screen mode.

Viewport: allows the display zones, called "viewports," to be manipulated and reorganized.

Editors: gives access to the different editors available.

Scripting: gives access to the different scripting modes.

Workspace: allows you to change the Patchwork 3D user interface by reordering the toolbars according to your uses. Each reorders of toolbars can be saved in a workspace.

Help: gives access to the help and information files.

Toolbars

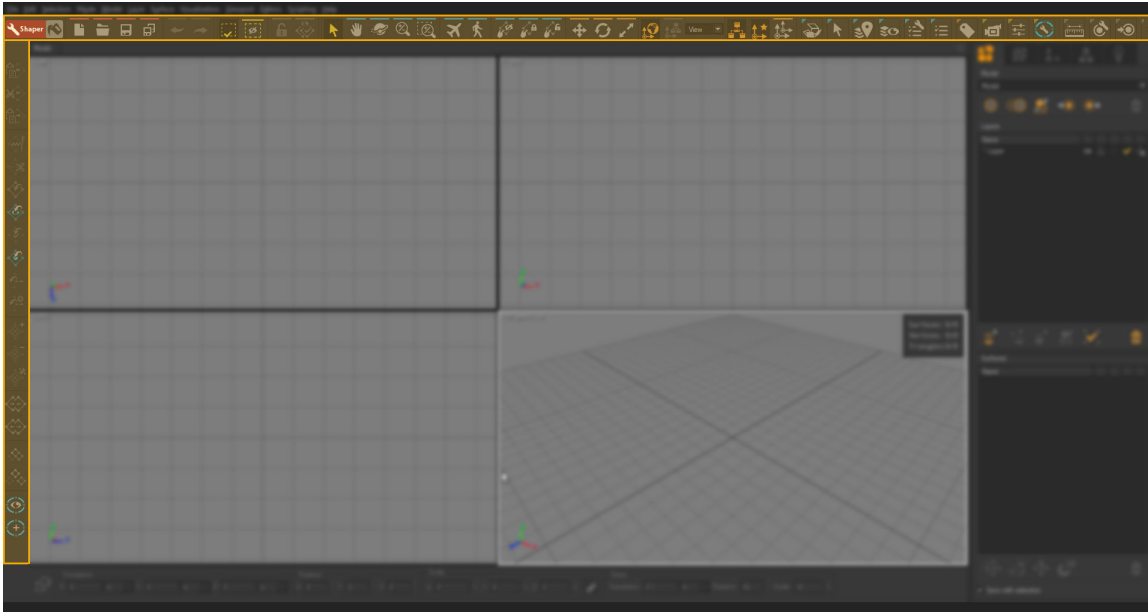

In Shaper, the toolbars are located at the top and on the left of the screen.

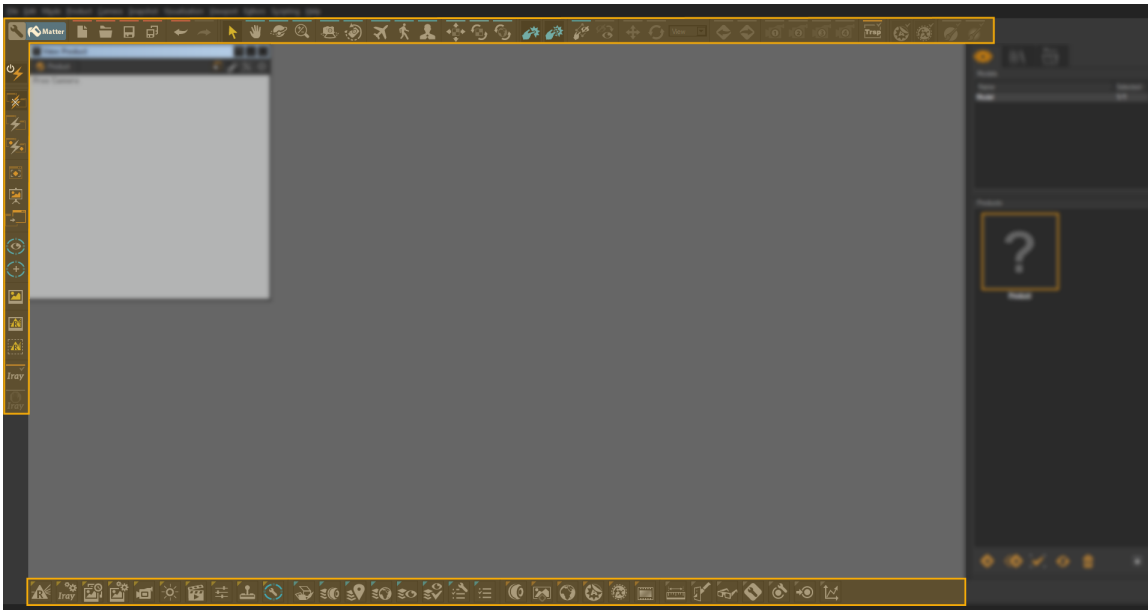

In Matter, the toolbars are located at the top and on the left of the screen. The editor toolbar is located at the bottom of the screen.

Toolbars provide quick access to the most common functions. You can move the toolbars around your screen and anchor them to the top or the left edges of the main window.

Workspace

Available in: **Shaper** or **Matter** : **Workspace**

A **Workspace** allows you to change the user interface of Patchwork 3D by reordering toolbars according to your uses. Each reorders of toolbars can be saved in a different workspace.

Several workspaces come with Patchwork 3D. The workspace named **Legacy** is the historical user interface of the software while the workspace named **Default** is an interface optimized for the uses of CG Artists with a selection of dedicated editors necessary for the creation of a Digital Aspect Mockup.

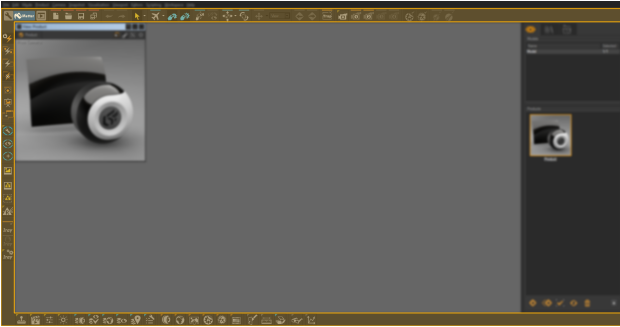

Example of the Matter module with the workspace **Default**.



Example of the Matter workspace module **Legacy**.

Select the desired workspace in the menu to display it.



NOTE

For **Shaper** the top and left toolbars of the Patchwork 3D user interface are customizable.

For **Matter** the top, bottom and left toolbars of the Patchwork 3D user interface are customizable.

You can also create your own workspaces from Python scripting. It is also possible to add new buttons related to a Python script: you can launch software or a website from the toolbar, develop new custom features using the P3D script API or automate routine operations. See the [scripting](#) documentation for more information.



Example of adding buttons linked to a Python script that executes one or more applications. Here, in this case, it is Accel VR, Lumis 3D, and Adobe Photoshop®.

To create a new workspace, we recommend using one of the spaces delivered with Patchwork 3D, for example, spaces named **Default** or **Legacy**. You will find them in the following location: `C:\Program Files\Lumiscaphe\Patchwork 3D 2026 X8 release 1 \workspaces`.

Workspaces created by you should be stored in the following location: `C:\ProgramData\Lumiscaphe\P3D\Workspaces` so that Patchwork 3D can list them in the **Workspace** menu. Click on **Open workspaces folder** to display the folder where workspaces are stored.

Configuration Scheme



NOTICE

New Features in Patchwork 3D 2026 X8

Available in: **Matter > Workspace** menu > **Configuration Scheme**

Principle



The **Configuration Scheme** workspace in Patchwork 3D automates the creation of configurations. It enables you to visually define color areas on the 3D model that will receive different materials. With just one click, you can generate the complete hierarchy of aspect layers and the corresponding configuration rules, eliminating repetitive entry and minimizing the risk of errors.

Two viewing modes:

- The **EDIT MODE** displays and activates the zone aspect layer to assign zone materials to surfaces. All generated material assignments are hidden, and the **Configuration Browser** has no visible effect in the viewport.
- The **VIEW MODE** shows the generated aspect layers. It allows you to preview the configurations generated via  **Configuration Browser**.



NOTE

Any modification of a zone made using the tools in the **Configuration Scheme** workspace, like its renaming  or deletion , automatically propagates throughout the structure, guaranteeing the consistency of configurations without manual intervention. Conversely, a rename performed manually outside of these tools, for example, directly on a material or a group of materials in the library, will not be propagated.

Each material zone has its own color to facilitate its identification. If two zones have colors that are too similar, it is possible to modify one without any impact on the process.



WARNING

The **Configuration Scheme** has been designed to work without further editing the aspect layers from the Aspect Layer Editor. It is best to use either the **Configuration Scheme** or the **Aspect Layers (Editor)** [143], but not both at the same time, to avoid configuration conflicts.



<https://www.youtube.com/embed/WDm9E4uM2TI>

When to use it?

- Regular updating (additions, deletions) of the materials used for each zone.
- Models requiring multiple aspect variants to be managed simultaneously.
- Configurations with multiple zones and materials to reduce the risk of manual assignment errors.
- Update or rename zones to be automatically propagated to all existing configurations.

Generate a configuration

The **Configuration Scheme** workspace associates each zone with a group of materials via a naming convention: the name assigned to a zone when it is created simultaneously defines the name of the color material (in **Zone Materials**) and the name of the group that will contain various materials. This correspondence allows the automatic generation of the hierarchy of aspect layers and configuration rules

1. In **Matter**, open the **Workspace** menu and select **Configuration Scheme**.
2. Click on  **EDIT MODE** to switch to edit mode.
3. Click on  **ADD ZONE** and name the zone, for example, "Plastic". This creates:
 1. a group of "Plastic" materials
 2. a group known as **Zone Materials** that includes a "Plastic" color material. **Zone Materials** thus makes the link with the material group.
4. From the **Zone Materials** group, assign the "Plastic" color material to the model's surfaces using drag-and-drop. This color material identifies these surfaces as belonging to the "Plastic" zone: during generation, they will be assigned materials from the corresponding group.



TIP

If this message appears, click **Apply to Configuration Scheme**. The option **Apply to Layer instead** would affect the material to the displayed aspect layer, outside of the structure **Configuration Scheme**. **Generate** could not take it into account.

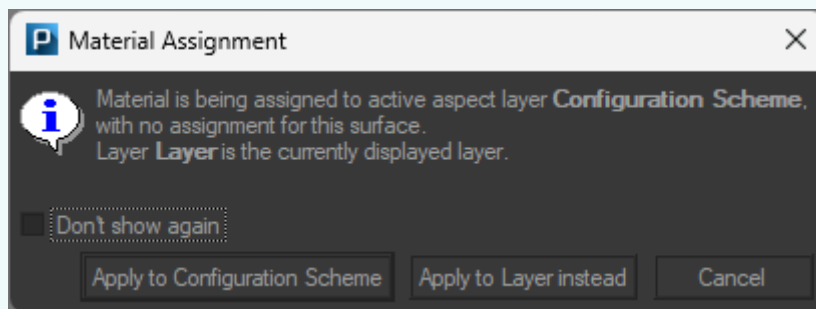



5. Repeat zone creation and color material assignment for each additional zone in the model.
6. Add the materials in the group corresponding to each zone.



TIP

It is also possible to drag and drop materials from the [Material Library \[323\]](#) in their corresponding material groups. (Example: "Plastic")

7. Click on  **GENERATE CONFIG** to automatically create the hierarchy of aspect layers and configuration rules.
The link is established by naming correspondence between the color material in each zone and the material group of the same name.
8. Switch to  **VIEW MODE** to visualize the result of your configurations.
9. Check the result in the  **Configuration browser**.

3D Viewport

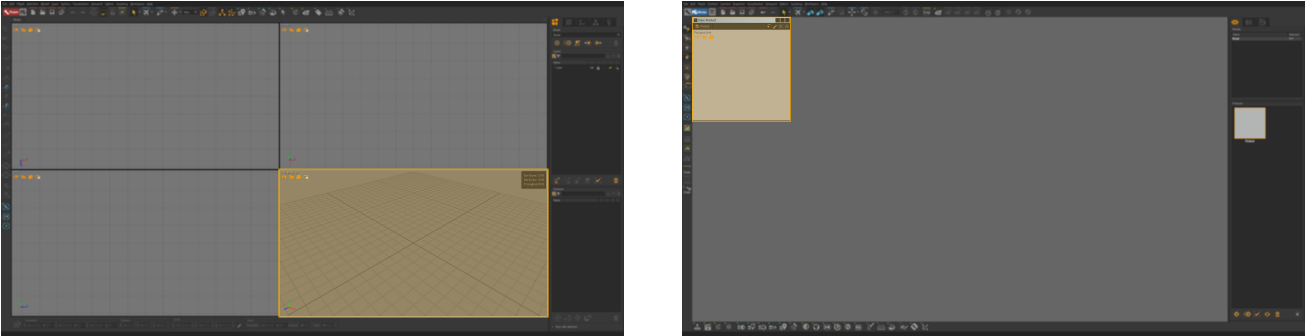

Viewports in *Shaper* (left) and *Matter* (right).

A viewport is a display window within the workspace that is used to show a 3D representation of the model or product being edited. Only one viewport can be active at a time.

The representation of the model or product is determined, in each viewport, by a viewpoint (the position of the observer) and by a look-at point (the point being observed). Several types of representation exist, depending on the active interface module. These render types are accessible via a right-click on the name of the viewport type in order to display the viewport's context menu.

Sidebar

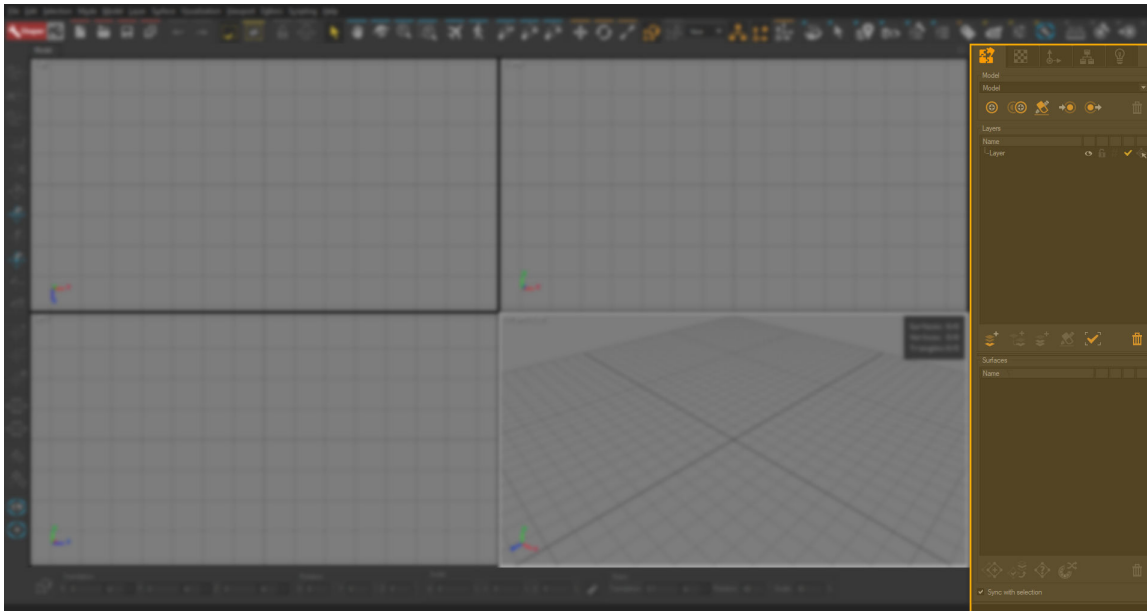

The sidebar provides constant access to the most common tools and determines the editing mode. The separator between the sidebar and the workspace is mobile, which provides a greater flexibility in the organization and division of the application's surface area.

In the sidebar in ***Shaper***, you will find the model, dressing, pivot, kinematics, and lighting tools.

In ***Matter***, browse the products, ***Matter*** elements (materials, textures, backgrounds, overlays, post-processing effects, and sensors) and their libraries.

Information Bar

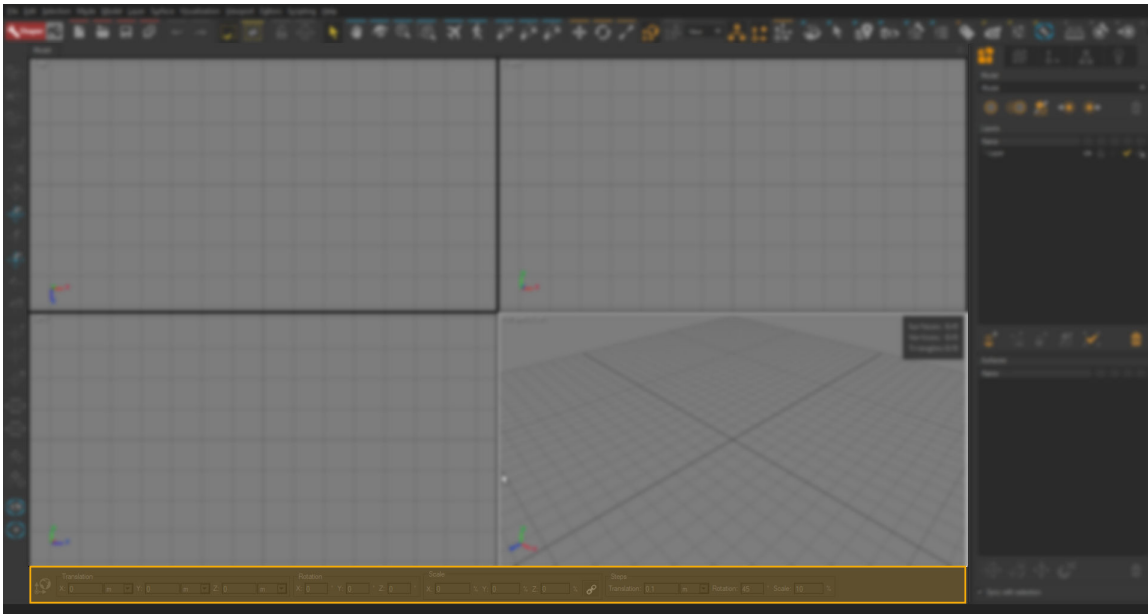

The space at the bottom of the main window is used to display additional information when you move a mouse over an option or an element of your model or product.

Status bar

The Save Reminder, which is present in the status bar, proactively reminds you to save your progress by displaying a visual alert in the lower right corner of Patchwork 3D.

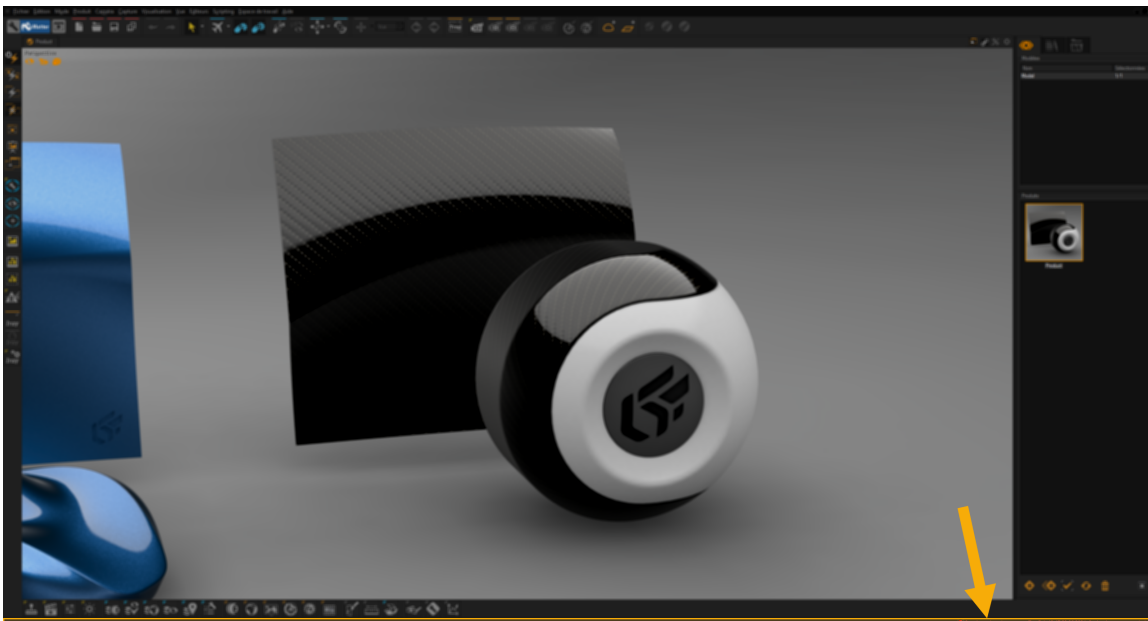

In the menu **Settings > Files** of the **Behavior when saving** box, you can customize the frequency of the reminder by choosing to be notified after a specific time interval, a predetermined number of actions, or both.

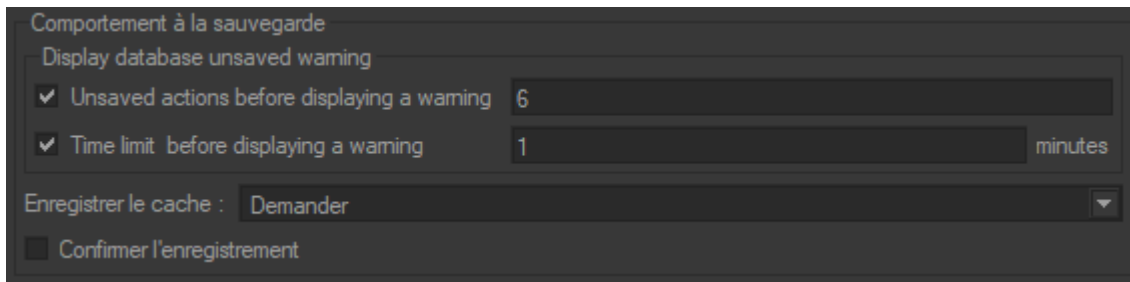

<https://www.youtube.com/embed/TzgMgdLsL7o>

Editors

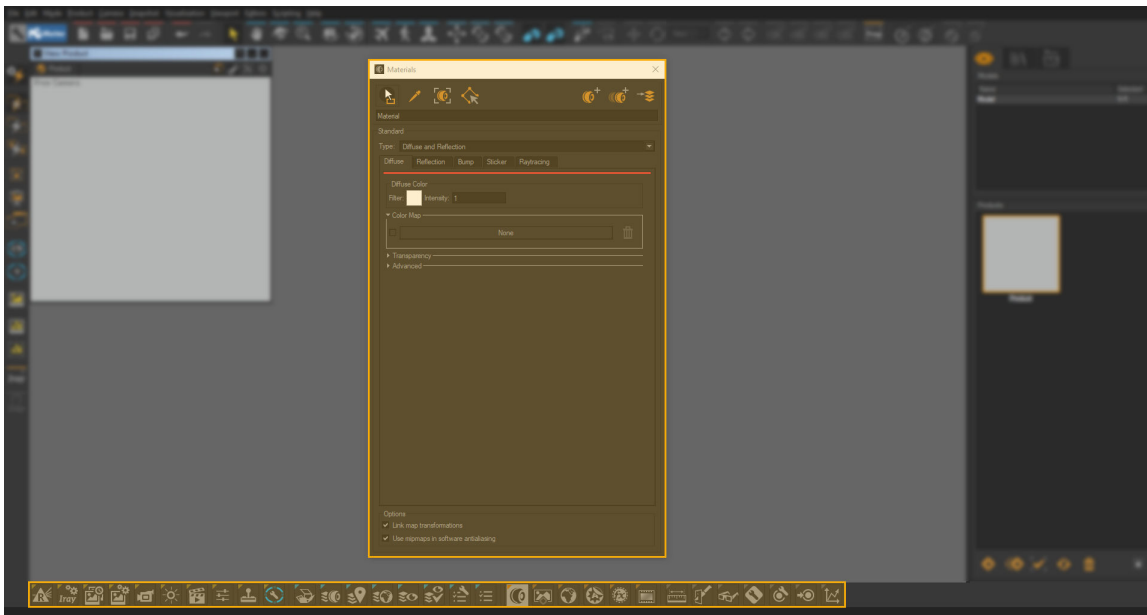

Editors are additional floating windows that give access to an element's settings. Most editors are accessible from the **Editors** menu or the corresponding toolbar, or from context menus.

Context Menu

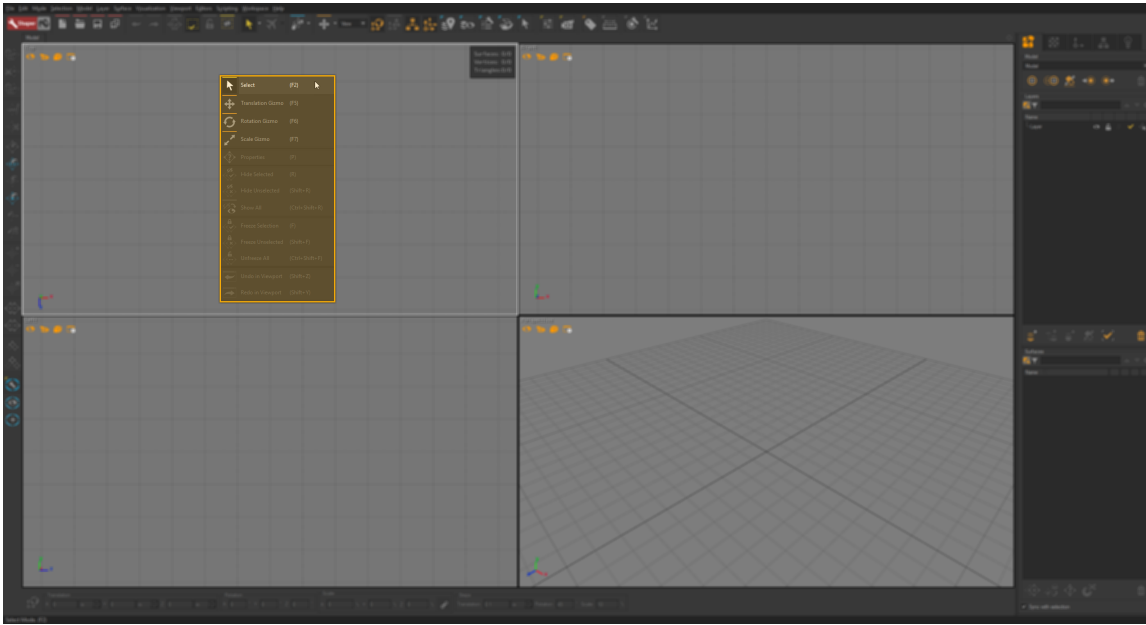

You can right-click on most elements in Patchwork 3D Design, whether that element is the upper-left corner of the viewports or a part of your model or product. This action displays a context menu listing options associated with the element in question.

Lists

Most lists in Patchwork 3D have search and filter functions.

Search function

Accessible from the following icon , the search function highlights all occurrences related to your search.

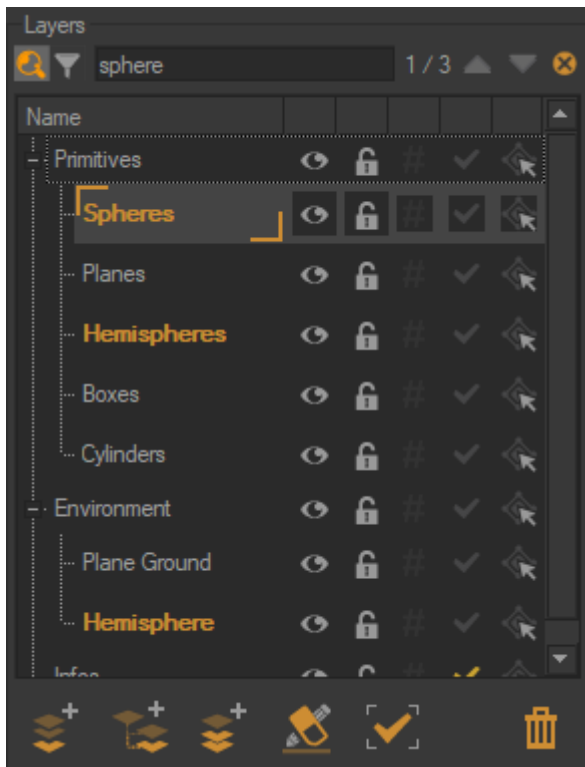

Filter function

Accessible from the following icon , the filter function reduces the search by hiding occurrences that are unrelated to the search.

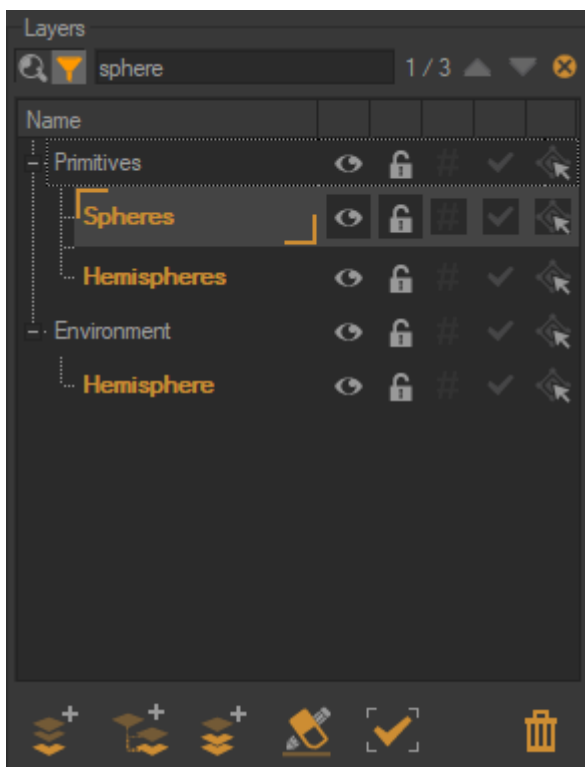

Items of a list or hierarchy

Patchwork 3D offers features that make it easy to change the state of items in a list or reorganize them in a hierarchy.

Change the state of multiple items in a list by clicking and dragging

Click and drag is very useful for changing, with a single click, the visibility, locking or selection state of items in a list. Thanks to this functionality, it is no longer necessary to individually select each item of a list to change their state.

The click and drag operation mode is easy to use. Select the first icon of the item in the list by holding down the left mouse button and expand the selection to the other icons of the items by moving vertically up or down, then release the left mouse button.



NOTE

When clicking and dragging, the visibility, locking or selection state of the first item in the list is applied to the other items in the selection.

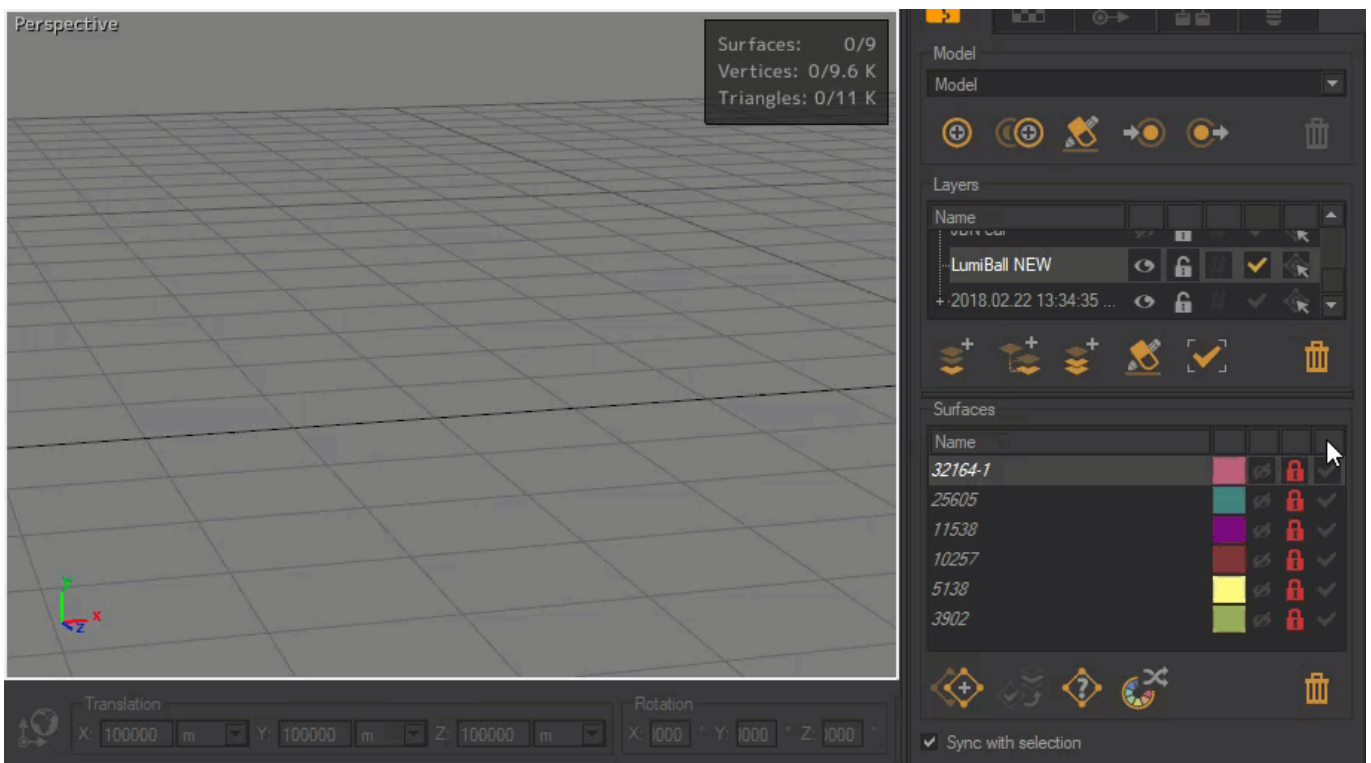

Example of changing the state of surfaces by clicking and dragging.

Rearranging items in a hierarchy

You can rearrange items in a list by a simply drag and drop.

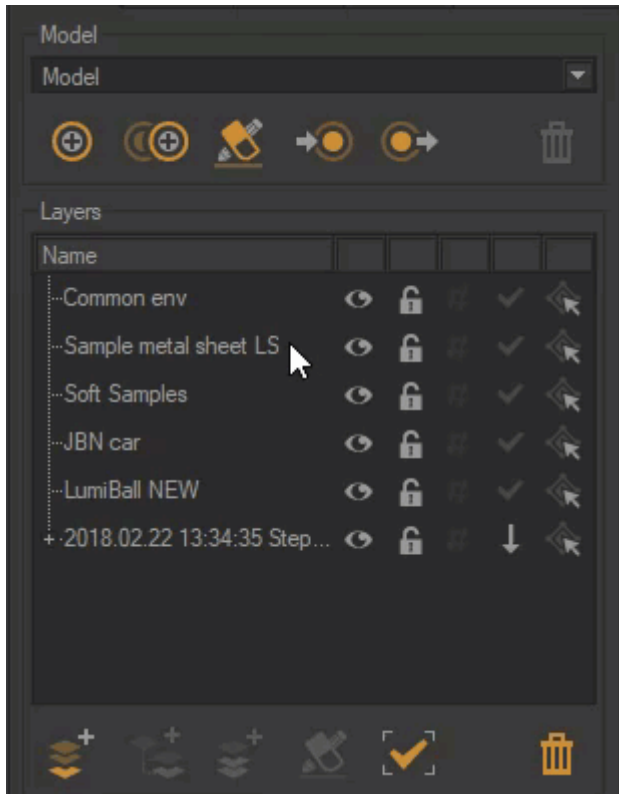

Data



NOTICE

All the features described below may not be present in your software edition: Community, Premium, Essential, or Enterprise.

P3D Database

In Patchwork 3D, the authoring data for a Digital Aspect Mockup is stored in a single file, a database using the P3D format. This file contains all of the raw editing information, the directory information for external resources, and the individual internal resources. Each element used to create the final rendering is stored in the .pd3 database whether or not it is used in the Digital Aspect Mockup that has been elaborated. For example, an image used to create relief in a texture, in turn, used in a material, is included in the P3D database.

Only one database may be open at a time.

A P3D database created with Patchwork 3D Community can be opened with Patchwork 3D Enterprise via a specific option.

Operations on the P3D database are available from the **File** menu:

- **New;**
 - **Open;**
 - **Reload** the last saved state of the database and discard any changes made since then,
 - **Recent:** a list of recently opened databases. The number of databases listed can be set in the [application settings \[53\]](#).
 - **Show Start Screen**
[More information below \[45\]](#).
-

- **Save;**

A database saved by a current version of Patchwork 3D may no longer be readable by earlier versions of the software. When you attempt to save an older database with a newer version of Patchwork 3D, the program will automatically ask you to confirm this action. Confirming the save will change the database version. To maintain a copy of the original file, use the **Save as** option instead.

- **Quick Save As**

Saves a copy of the opened file. No optimization is made.

- **Save as;**

Saves a copy of the opened file by defragmenting the data and optionally cleaning caches to reduce the size of the final file. Please note, that the saving time is longer than the Quick Save As. The larger the size of the database, the longer the saving time.

We have prepared a comparison of the saving time between the **Quick Save As** option and the **Save As** option with cache to illustrate the advantages of this option. [Click here to learn more.](#)

By using the **Save As** functionality, you can:

- **Do not save cache**, Patchwork 3D will purge the cache to save the database. The result is a significantly lighter database that will take a little longer to load the next time you open it.
- **Save all**, Patchwork 3D will keep the rendering cache. The next time the database is opened, Patchwork 3D will load the data faster based on the existing renderings.

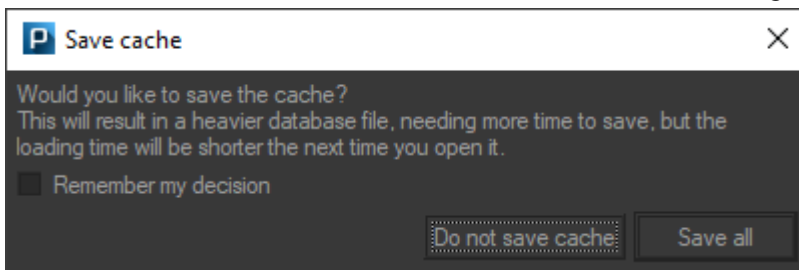

- **Save and clean;**

This feature allows you to save a version of your database free of unnecessary data such as deleted data which you no longer need. Its benefit is to decrease the database size. But, on the other hand, the time to save the database is lengthened.

The options of **Do not save cache** and **Save all** are also available with **Save and Clean**. Please refer to the previous point to understand how it works.



TIP

- Use **Save (Ctrl + S)** frequently during your work session.
- If you plan to work on the database again, at the end of your work session, use **Save and clean** and **Save all** instead. In this way, the rendering cache will be saved.
- If you plan to share or archive the database you are working on, use instead **Save and Clean** without keeping the rendering cache (**Do not save cache**).

- **Import in a new database,**
- **Export**
 - In **Shaper** UI, it exports the current model. The following formats are supported: OBJ, P3DXml, and FBX.
 - In **Matter** UI, it exports the current product. The following formats are supported: FBX, KDR, LSD, and MI (Iray).
- **Settings,** see details in the [Settings \(Editor\) \[53\]](#) chapter.
- **Keyboard Map,** see details in the [Keyboard Map \(Editor\) \[224\]](#) chapter.
- **Edit Database Properties,** see details in the [Database Properties \(Editor\) \[214\]](#) chapter.
- **Print,** see details in the [Printing \[468\]](#) chapter.
- **Discard Patchwork 3D Operation History.**
- **Optimize Meshes.**
- **Log out and Quit,** see details in the [Getting Started \[23\]](#) chapter.
- **Quit.**

Start Screen

Start Screen has been made to quickly give you an idea of what Patchwork 3D can do for you. Several samples are available to guide you in a creation of a Digital Aspect Mockup (DAM).

Start Screen consists of two tabs:

- the **Recent Files** that lists last modified files.
- **Sample files** .

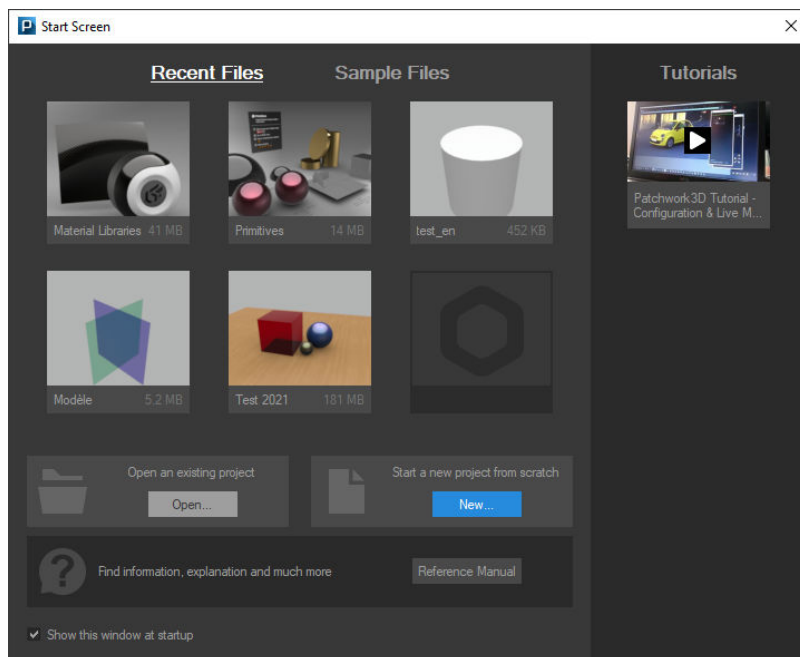

Start Screen window

Open... button allows you to open an existing DMA, while **New...** button lets you start a DMA from scratch.

Lumiscaphe videos button links you to the Youtube channel of Lumiscaphe.

Uncheck **Show this window at startup** if you don't need this window shows up on the next launch of Patchwork 3D. If you want to see it again, just click **File** and **Show Start Screen**.

Resources in a P3D File

The P3D file contains many resources, including:

- Lighting sets,
- Color palettes,
- Image and video files used as textures,
- Materials,
- Image files used as backgrounds,
- Gradients,
- Lighting environments,
- Camera hierarchies,
- Camera position lists (.kam file),
- Sensors,
- Overlays,
- Post-processing sets.

All of these resources are fully integrated in the P3D file. Even if they originally came from external sources, once the database has been saved, Patchwork 3D will never require access to the original file.



NOTE

When transferring a P3D database from one computer to another, you will only need to move the P3D file. All of the resources are contained in this one file.

Many of these resources can also be exported or imported, making them transferable between P3D databases. They can, for example, be stored in a common library which can be specified in the preferences and accessed via the explorer in the **Matter** sidebar.

Model

A model is a full set of 3D geometric and spatial information derived from an imported CAD file. It is composed of **Shaper** objects such as surfaces, positions, and animation objects such as nulls, vectors, and axes. The model also contains information regarding **Shaper** object properties, including UV mapping coordinates, visibility settings, lightmaps, tessellation levels, and relationships with other **Shaper** objects.

A P3D database may contain several models.

Product

A product is a 3D derivative of a model to which an aspect has been or can be assigned.

Multiple products may be produced for a single model.

Digital Aspect Mockup

In order to be used with the Lumiscaphe software suite of 3D visualization tools, the raw authoring data must be exported as a Digital Aspect Mockup (DAM) in the format KDR. This format contains only the data required by the rendering engine in order to display the product variants and configurations created in Patchwork 3D. The image underlying the relief in a texture is no longer present; only the resulting calculations needed to display a material using that texture are conserved. Consequently, authoring is not supported in this format. The KDR is optimized to load more quickly: unlike the P3D format, in which the displayed images must be calculated when the file is opened, the data in the KDR can be transmitted directly to the graphics card without further treatment.

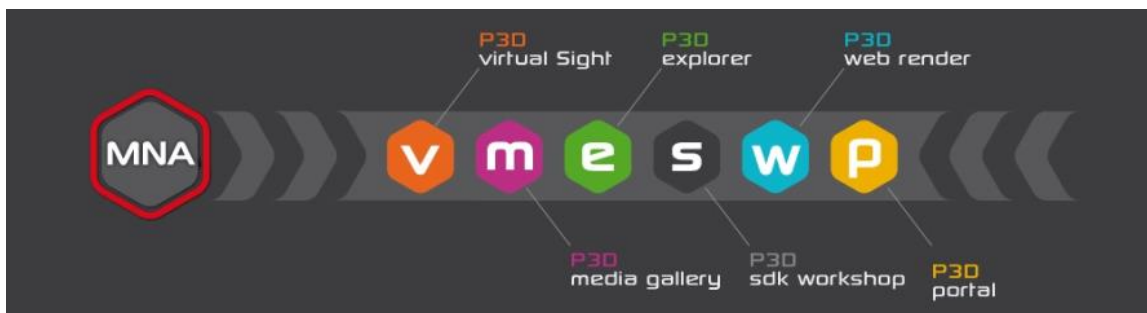

The Digital Aspect Mockup may then be used as-is in any of the Lumiscaphe visualization solutions.



Undo/Redo Mechanism

The undo/redo level specified in the [Settings \(Editor\) \[53\]](#) defines the number of operations that you can undo or redo at any moment and in a given context. The greater the number, the more information saved in memory by Patchwork 3D. It is possible to have an unlimited number of memorized operations. However, each memorized operation may occupy a large amount of memory. A limit of 20 operations is generally sufficient.

The undo/redo operations are not saved in the P3D database: when you load a database, you cannot undo any of the operations performed during a previous editing session.

- **Edit >  Undo All** or **Edit >  Redo All**: Undo all memorized operations at once.
- **File > Discard P3D Operation History**: Discard the memory of all information used to undo previous operations in the application. This operation can free up a large amount of memory and significantly reduce the size of the file during the next save.
- **Edit > Discard Module Undo History**: Discard only the undo operations in the current module (**Shaper** or **Matter**).

Shaper

- **Edit > Undo all** or **Edit > Redo all** : Undo or redo all memorized operations at once.

The **Shaper** viewports also have their own undo/redo history:

- **Viewport > Undo in Viewport**: Undo the last operation performed in the active viewport.
- **Viewport > Redo in Viewport**: Redo the last operation undone in the active viewport.

Matter

In **Matter**, products have their own undo/redo history:

- **Product > Undo**: Undo the last operation performed on the active product.
- **Product > Redo**: Redo the last operation undone on the active product.

Default Keyboard Shortcuts

Available in:

- **Shaper or Matter: File > Keyboard Map > Show as HTML**
- **Help > Keyboard Shortcuts**

Patchwork 3D includes the mechanism to assign operations to a keyboard or mouse shortcut. You can keep the default configuration or define your own shortcuts.

The default keyboard shortcuts may be consulted or modified at any time. Custom shortcuts may also be assigned to additional operations. These operations are listed in the **Keyboard Map Editor**.



NOTE

Matter's keyboard shortcuts are also accessible in the floating viewport of **Matter**, even if you are in **Shaper** module. However, not all editor features are supported.

Application	
Show Help	F1
Show Matter Module	Ctrl+2
Show Shaper Module	Ctrl+1
Save Database	Ctrl+S
Save Database As	Ctrl + Shift + S
Edit Keyboard Map	Ctrl+B
Print	Ctrl+P
New Database	Ctrl+N

Application		
Open Database		Ctrl+O
Surface Cutting Workshop		
Pick Camera Look-At Point		Ctrl+Space
Unfolding Workshop		
Pick Camera Look-At Point		Ctrl+Space
3D Selection Only		Space
Shaper		
Show Edged Faces		(
Track Culling in Red in Active Viewport]
Show Active Layer		Ctrl+T
Hide Frozen Surfaces		D
Show Selected Only		S
Show All Surfaces		Ctrl+Shift+R
Pick Camera Look-At Point		Ctrl+Space
Hide Unselected Surfaces		Shift+R
Hide Selected Surfaces		R
Paste surfaces to active layer		Ctrl+V
Copy Selected Surfaces		Ctrl+C
Cut Selected Surfaces		Ctrl+X
Move Selected Surfaces		Shift+C
Decrease Triangulation of Selected Surfaces		Ctrl+-
Undo Last		Ctrl+Z
Undo Last in Active Viewport		Maj+Z
Redo Last		Maj+T
Unfreeze All Surfaces		Ctrl+Shift+F
Split Selected Surfaces		Shift + G
Edit parameterization of surface unfolding		Shift + U
Edit Properties of Selected Surfaces		P
Tag Manager		Ctrl+M
Rotation Gizmo		F6
Translation Gizmo		F5
Increase Triangulation of Selected Surfaces		Ctrl++
Invert Selection		Ctrl+Shift+A

Shaper	
Stitch Selected Surfaces	G
Lock Selection	Space
Active Viewport Maximization	A
Set Interaction Mode to Pan.	X
Set Interaction Mode to Orbit.	C
Set Interaction Mode to Zoom Region.	V
Set Interaction Mode to Zoom.	Z
Select All Elements Enclosed by Region Mode	F4
Select All Elements Touched by Region Mode	F3
Select Mode	F2
New active layer	T
Set Active Viewport to Isometric	Shift+L
Set Active Viewport to Perspective	L
Set Active Viewport to Back View	Shift+O
Set Active Viewport to Bottom View	Shift+I
Set Active Viewport to Top View	I
Set Active Viewport to Right View	Shift+K
Set Active Viewport to Front View	O
Set Active Viewport to Left View	K
Shaper Active Viewport Maximization	Ctrl+Y
Redo Last in Active Viewport	Shift+Y
Restrict interaction to the XY plane	Shift+F7
Restrict interaction to the YZ plane	Shift+F8
Restrict interaction to the ZX plane	Shift+F9
Restrict interaction to the X axis	F7
Restrict interaction to the Y axis	F8
Restrict interaction to the Z axis	F9
Select None	Shift+A
Select All	Ctrl+A
Delete Selected Surfaces	Del
Dressing Component Interaction	F12
Surface Component Interaction	F11
Lock Active Layer	Ctrl+Shift+T
Freeze Unselected Surfaces	Shift+F
Freeze Selected Surfaces	F
Active Viewport: Enable Backface Cull	-
Render active viewport in bounding box mode	Shift+B
Render active viewport in wireframe mode	Shift+W

Shaper

Render active viewport in smooth mode	Shift+S
Render active viewport in smooth and highlights mode	Shift+H
Zoom Active Viewport to View Full World	Q
Zoom Active Viewport to View Full Selected Surfaces	E
Zoom All to View Full Selected Surfaces	Shift+E
Zoom All to View Full World	Shift+Q

Text texture

No pre-defined shortcuts for this group.

Timelines

No pre-defined shortcuts for this group.

Image viewer

No pre-defined shortcuts for this group.

Matter

Surface Depth Write under Cursor	,
Activate Full Screen Mode	Y
Assign Background under Cursor	F
Assign Active Material under Cursor	C
Modify backface visibility for surface under cursor	F6
Show Background Editor	Shift+F8
Show Material Editor	F5
Show product properties	F8
Show All Surfaces	Ctrl+Shift+R
Assign Environment to Surface under Cursor	G
Assign Environment to All Surfaces Using Material under Cursor	Shift+G
Pick Background under Cursor	R
Pick Environment under Cursor	T
Pick Material under Cursor	E
Set Camera Focus Plane from Picker	Shift+Space
Pick Camera Look-At Point	Ctrl+Space
Undo Last	Ctrl+Z
Undo Last for Active Product	Shift+Z
Tile Viewports	Ctrl+Shift+C

Matter	
Edit Background under Cursor	Shift+R
Edit Material under Cursor	Shift+E
Store Bookmark 1	Ctrl+F9
Store Bookmark 2	Ctrl+F10
Store Bookmark 3	Ctrl+F11
Store Bookmark 4	Ctrl+F12
Pan Mode	X
Orbit Mode	C
Rotate Material Mode	F4
Select Mode	F2
Translate Material Mode	F3
Modify backface visibility for surface under cursor	N
Material Library	1
Texture Library	2
Background Library	3
Environment Library	4
Overlay Library	5
Post-Processing Library	6
Previous Active Viewport Tab	Q
Next Active Viewport Tab	S
Set Active Viewport to Isometric	Shift+L
Set Active Viewport Mode to Walk	B
Set Active Viewport Mode to Fly	V
Set Active Viewport to Perspective	L
Set Active Viewport to view from Back	Shift+O
Set Active Viewport to Bottom View	Shift+I
Set Active Viewport to Top View	I
Set Active Viewport to Right View	Shift+K
Set Active Viewport to Front View	O
Set Active Viewport to Left View	K
Shaper Active Viewport Maximization	Ctrl+Y
Redo Last for Active Product	Shift+Y
Restore Bookmark 1	F9
Restore Bookmark 2	F10
Restore Bookmark 3	F11
Restore Bookmark 4	F12
Zoom to View Full Active Product	Z

SETTINGS

Available in: **Shaper** or **Matter: File > Settings**

The **Settings** editor covers application-wide settings.

General Tab

Patchwork 3D supports English, Japanese and Chinese. Choose your preferred language for the interface here.

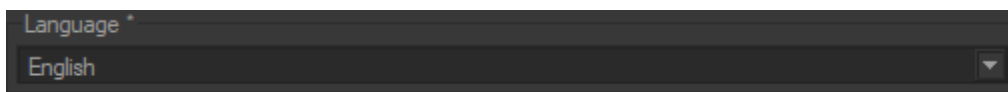

The box **Usage statistics** informs the user about the behavior of Patchwork 3D on the collection of usage statistics. At any time you can change this behavior by selecting the following options:

- **I do not agree to the collection of usage statistics.**
- **I agree to the collection of anonymous usage statistics.**
Information collected is as follows: the equipment used, the identifier of the anonymized user, the duration of the session and the actions carried out in Patchwork 3D.
- **I agree to the collection of usage statistics.**
Information collected is as follows: the material used, the name of the license used (Enterprise edition) or email (Community and Premium editions), the duration of the session and the actions carried out in Patchwork 3D.

When the **Remember size of windows** option is checked, Patchwork 3D memorizes the size and position of its window when you close the application. On the next startup, the main window of the application resumes the size and position previously memorized.

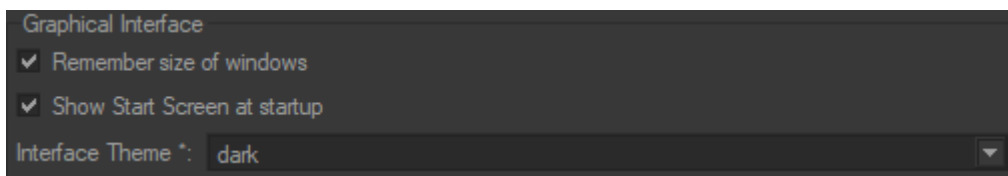

The **Undo/Redo** zone combines all the options concerning the **Undo/Redo** system of the application. If the **Limit to** box is not checked, then the number of memorized operations is infinite. When the box is checked, the number of operations is limited to the value given on the right. You can change this value by clicking in the editable field or by using the two arrowhead buttons on the right. A limit of 20 operations is generally sufficient. The changes made to the undo/redo system will not be taken into account when the application is restarted. For more information, see the section on the **Undo/Redo Mechanism**.



The **Controllers** zone offers a selection of additional controllers. Check the box to the left of the additional controller you wish to select. The name of the controller is a button that allows access to the window for setting the speed and sensitivity for various actions. You can choose to add the following additional controllers:

- SpaceMouse
- Xbox controller



Use the keyboard to enter numerical values in order to increase/decrease the speed/sensitivity of the mouse.

File Tab

The recent **Databases** zone allows you to indicate the maximum number of files that will be available in the **File > Recent** menu. The default value is 9; you can change it to any value from 0 to 99.

The **Opening Behavior** zone allows you to specify which objects should be loaded into memory when a database is opened. If loading a database is very slow, it is often possible to speed up the initial loading to be able to open your database more quickly.



The **Reset loading warnings** button enables the warnings for which you might have previously checked **Do not tell me again**.



NOTICE

The **Saving behavior** zone allows you to tailor the saving behavior of changes you make to your database.

You can customize the reminder frequency by choosing to be notified after a specific time interval, a predetermined number of actions, or both.

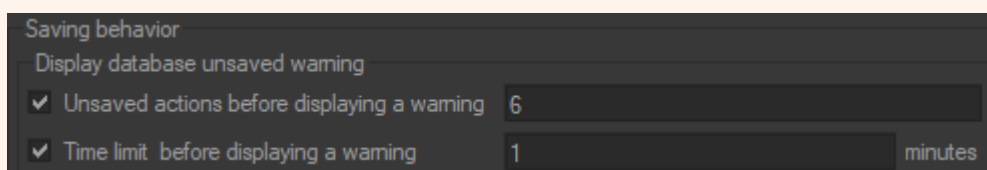

- **Ask**, Patchwork 3D will ask you each time you save your database if you want to save or not the cache.
- **Save cache**, Patchwork 3D will keep the rendering cache. Next time the database is opened, Patchwork 3D will load the data faster based on the existing renderings.
- **Do not save cache**, Patchwork 3D will purge the cache to save the database. The result is a significantly lighter database that will take a little longer to load the next time you open it.

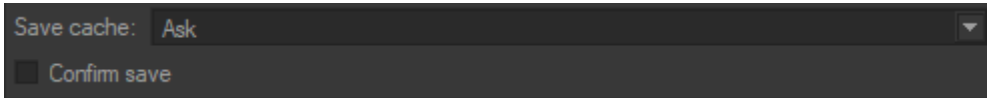

Whether **Confirm save** is enabled (checked), Patchwork 3D will ask you for a save confirmation each time you want to save your work. This option is useful when you have a large database that requires some time to save. Choose if you want to wait or delay the save. By default, this option is disabled.

The **Color Books** zone allows you to specify the Adobe directory from which Patchwork 3D will be able to find color books in **Adobe Color Book** file format (*.acb) that are used in Photoshop. It functions like a standard file explorer.

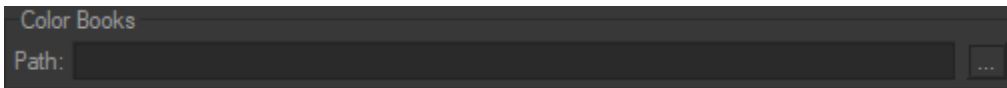

The **Exporters** zone groups together required information for certain exporters such as the **exporter for P3DXml [254]** that has an option to **Export ACIS files in binary mode**. This option is enabled by default.

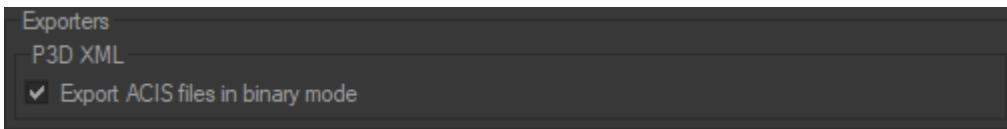

If **Let Matter library elements have the same name** is checked this allows resources (**Material, Texture, Background**, etc...) in **Matter** libraries to have the same name. Conversely, if the parameter is unchecked, you will be invited to change the name because two resources can have the same name.

Three choices are then possible:

- **Keep asking**: Patchwork 3D will suggest a new name each time, which you must then validate by clicking on **Rename** button. If you tick **Do not ask again**, Patchwork 3D will remember your choice the next time.
- **Rename**: Patchwork 3D will automatically rename the resource as Microsoft Windows does when you have two files with the same name.
- **Ignore** Patchwork 3D will cancel the renaming if there is a conflict.

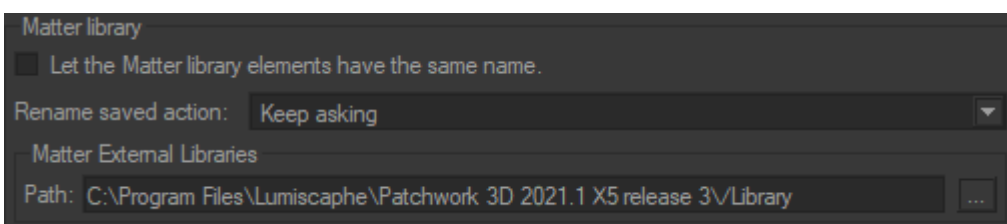

User Interface (UI) Tab

The UI tab provides controls for elements of the user interface.

In the **viewport** of **Shaper**, you can:

- Force 3D Patchwork to **Switch to isometric in orbit**. This option is disabled by default. When enabled, the 3D viewport switches automatically to isometric mode when the **Orbit** navigation mode (**Mode > Orbit** or the **C** keyboard shortcut) is selected.
- **Flip image vertically** in all of the open viewports. This option, which is disabled by default, is not compatible with the Head Up display (**Visualization > Head Up**).



In the main interface of **Shaper**, you can:

- **Show head up display at startup**. This option is enabled by default.
- **Use same viewport configuration for all models**, if your database includes several. This option is disabled by default.
- Check **Use the same aspect ratio as Matter for the active viewport in Shaper** option if you want to keep the same aspect ratio of views between Matter and Shaper.

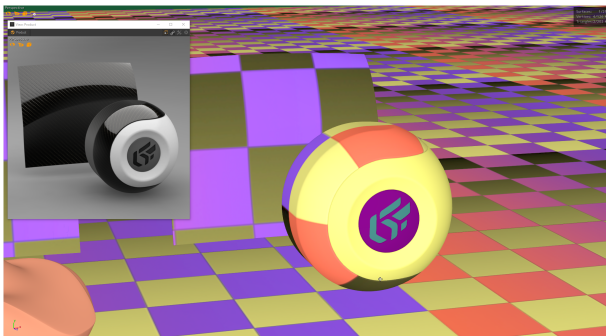

Here, the aspect ratio of the Shaper viewport is not maintained compared to the Matter viewport (left window).

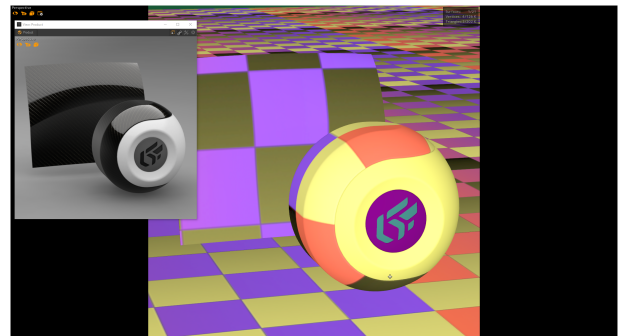

Here, the aspect ratio of the Shaper viewport is maintained compared to the Matter viewport (left window).

- **Use custom interface color**. This color is used for the background of the menu bar and for the background of the information bar at the bottom of the interface. Click on the color thumbnail in order to choose a different color.
- Indicate the colors to use for the border around the active viewport for the **Show Selected Only** option. Click on the color thumbnail in order to choose a different color.
- Indicate the colors to use for the border around the active viewport for the **Lock Selection** option. Click on the color thumbnail in order to choose a different color.

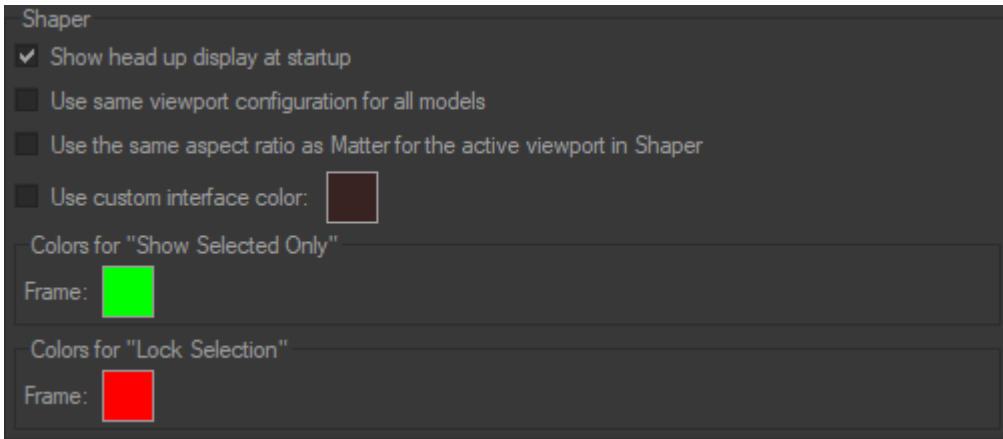

In the main interface of **Matter**, you can:

- **Automatically update product thumbnail** in the right-hand sidebar. This option is enabled by default.
- **User multilayer material as default material**. This option is disabled by default.
- **Use stylized material thumbnail**.
- **Use custom interface color**. This color is used for the background of the menu bar and for the background of the information bar at the bottom of the interface. Click on the color thumbnail in order to choose a different color.
- Set the product tab policy for the 3D viewports. In the **Show product tabs** drop-down menu, choose one of the three options:
 - **Always**: tabs will always be shown in viewports, even when there is only one product loaded in the viewport.
 - **When needed**: tabs will be visible when several products are assigned to the same 3D viewport. Otherwise, tabs will not be show in viewports.
 - **Never**: tabs in viewports will never be show. Several products may still be assigned to the same 3D viewport, but the interface does not provide a clickable means of navigating among them.

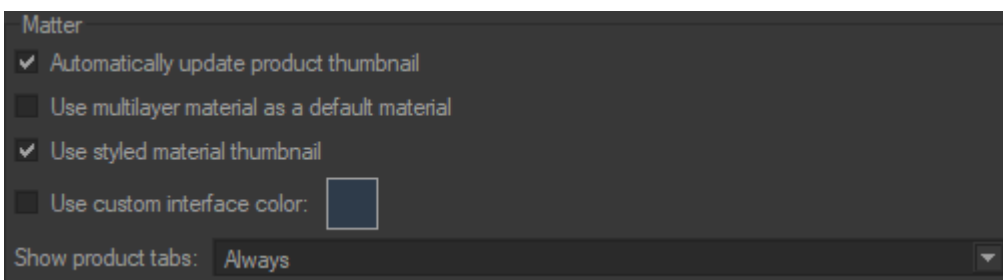

You also have control over certain properties of the main monitor. You can correct the values calculated by default for the **Width of the main screen** and its **Resolution**.

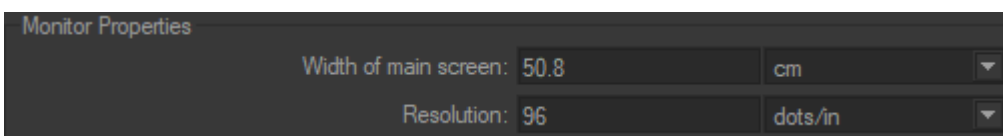

Geometry Tab

The **Geometry** tab provides general options for importers, as well as various options specific to the importers for Parasolid (IGES), ACIS, and Alias Studio.

In the **General Import Options**, the **Define default units** button gives you access to the window for configuring the units used by default during the importing of the 3D models.

The default measurement units for formats 3DS, DXF, WAVEFRONT OBJ, and STL can be defined by using the associated drop-down menu. By choosing the **User-defined** entry of the scroll-down menu, you have the possibility of entering an arbitrary value in the editable field on the right.



WARNING

Many of these imports are optional add-ons. Some may not be available depending on your specific software license.

The **Ignore files already imported** zone allows you to optimize your imports by not repeating the import of files that have already been imported. For example, if you regularly import all the files from a given directory, you don't need to worry about choosing only the new files the next time you import.

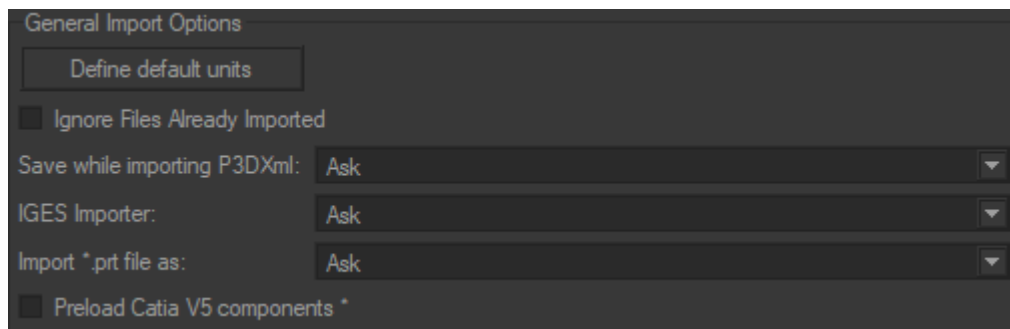

Access the options specific to the Parasolid (IGES), Alias Studio and, Catia importers that you wish to set up.

Lighting Tab

The lighting engine powers the lighting in Patchwork 3D. Depending on the configuration of your computer and the settings in this tab, the lighting engine may require a lot of resources. The default values, however, are generally sufficient, though you have to option to disable the engine by unchecking the box **Enabled**.

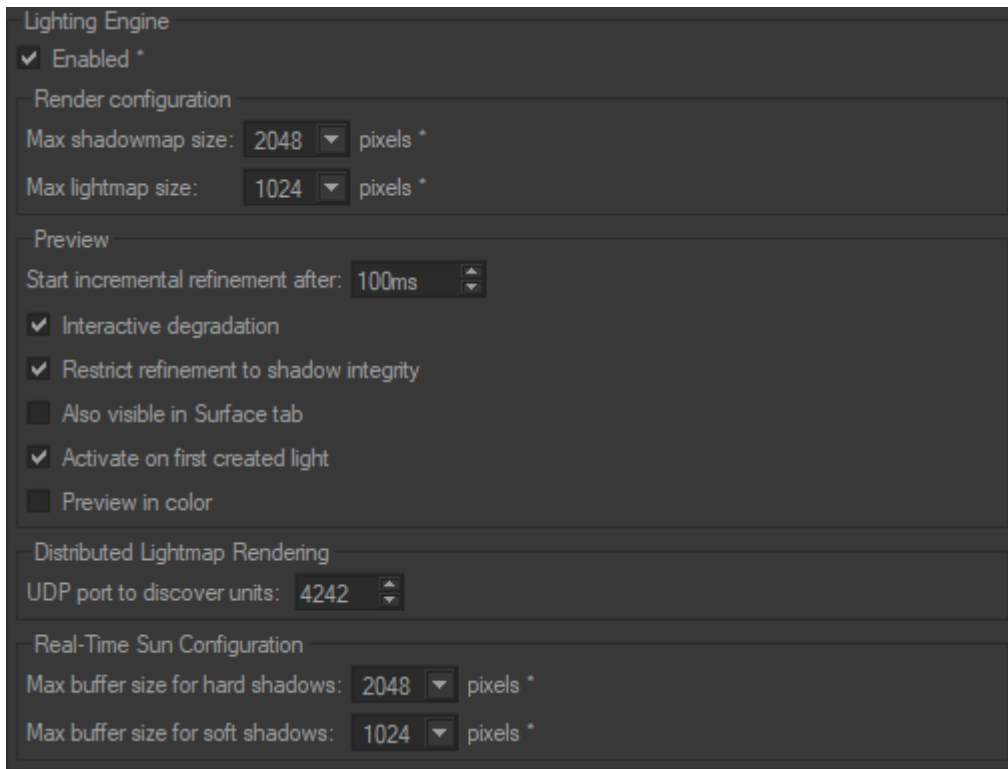

By default, the Render configuration is limited to:

Option	Default value
Max shadowmap size	2048px
Max lightmap size	1024px

The **Preview** mode, available in the **Lighting** tab in the **Shaper** sidebar, can also be personalized. You can set the length of time with no interaction before the incremental refinement begins (**Start incremental refinement after**) and enable or disable the following options:

Option	Default value
Interactive degradation	enabled
Restrict refinement to shadow integrity	enabled
Also visible in Surface tab (when the Surface sidebar tab is active)	disabled
Activate on first created light	enabled
Preview in color	disabled

If you use Distributed Lightmap Rendering, you also have the choice to set the **UDP port used to discover units** used for rendering.

To manage the memory resources required by the use of a **real-time sun** [235], provide the max size for hard and soft shadow buffers. The values by default are sufficient in most cases.

Color Tab

Color Management is responsible for many of the strong points in the render quality.

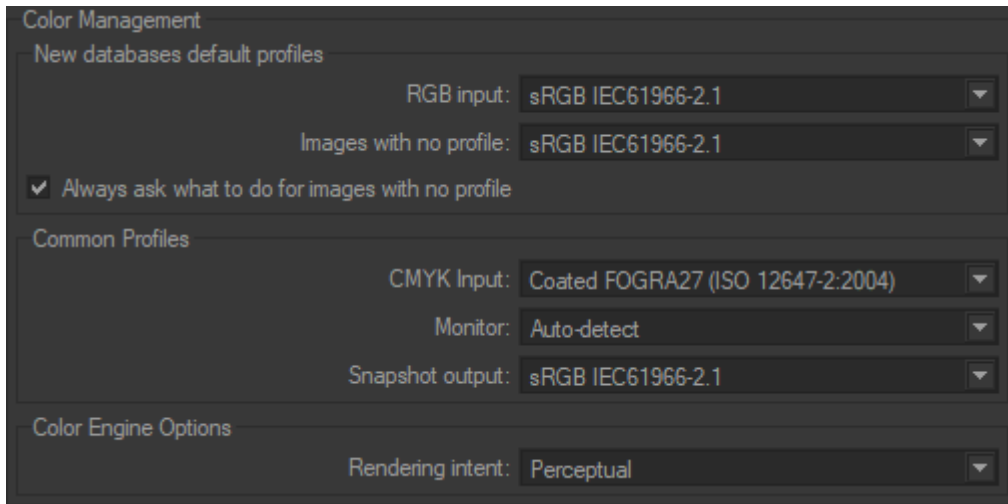

Color management profiles are a Shiftor technical tool in Patchwork 3D. They are responsible for many improvements in render quality. These improvements have made it possible for Patchwork 3D to make a considerable leap towards ultimate realism in rendering. The colorimetric profile defines the interpretation of the color values (RVB, CMYK or LAB) by matching them with measurable physical quantities (expressed in the space CIE XYZ or LAB). For the rendering and adjustment of materials displayed on the screen to be consistent with the colors and the shades of the real materials, it is essential to work in a defined colorimetric space. Patchwork 3D provides tools for defining, installing and managing the colorimetric profiles of the workspace, of imported images and of images produced by the software.

Rendering Tab

This tab gathers in two boxes the parameters for the options of the OpenGL engine and the raytracing engine.

OpenGL Engine Options

The **Hardware Antialiasing** controls the behavior of the antialiasing system of the application used to delete image aliasing effects. Depending on the video card used, it is also possible to disable the hardware antialiasing, or to enable it with different qualities (2x, 4x, 8x, 16x, 32x, 64x).

The antialiasing is enabled in both interfaces, **Matter** and **Shaper**, by default. If you do not wish to view the effects of the antialiasing, you can increase rendering speed in **Shaper** by deactivating antialiasing for Shaper only. To do so, uncheck the box **Available in Shaper**.

The **Default Depth Policy** sets the depth buffer. If the default policy **Frustrum based** does not meet your needs, you can choose between the options **Look-At point** based and **Fixed depth range**. This latter option allows you to provide personalized values for the minimum (**ZMin**) and maximum (**ZMax**) depths.

The **Display Zone** sets the default maximum resolution for viewports. Three options are available: **Main screen**, **Maximum dimensions** or **Cover all screens**. Respectively, these options apply the resolution for the main screen, the greatest height and greatest width of the available screens, or allow for the creation

of a viewport spanning all screens. When a viewport is displayed in a zone larger than its maximum resolution, black bars are added to compensate for the difference between the maximum resolution and the larger display resolution.

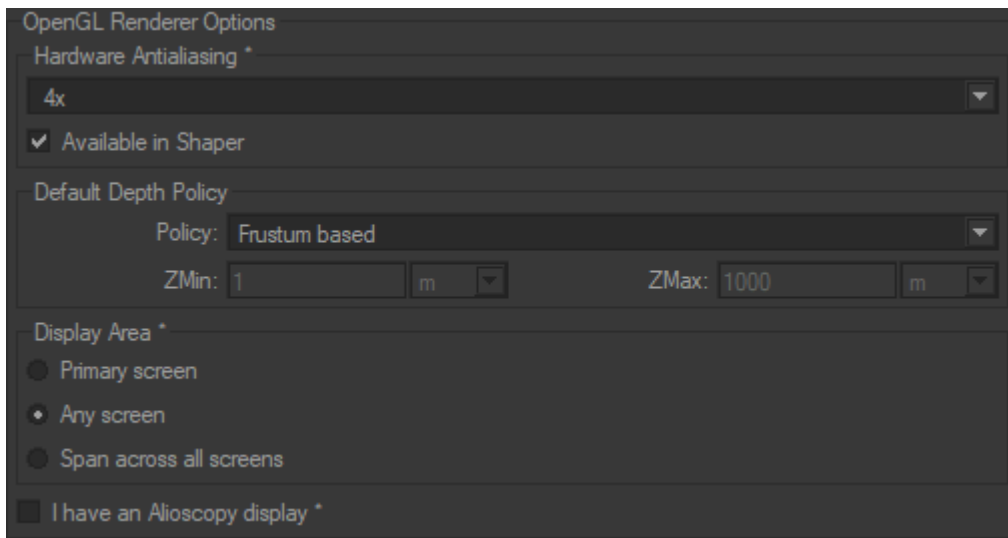

I have an Alioscopy display telling Patchwork 3D that you are using an alioscopy screen that displays 3D in relief without using glasses 3D. This activates the alioscopy options in **Matter** to adjust the number of renderings that Patchwork 3D must calculate per image to have the 3D in relief on the screen.

Raytracing Engine Options

This zone permits the CPU resources to be allocated to the raytracing engine to be defined. Three options are available: ***Use all CPU cores***, ***Use all CPU cores but one***, and ***Manual thread count***.

The ***Tile size*** in pixels can also be set. During the calculation of a rendering via raytracing, the image is rendered and displayed tile by tile in the viewport. The smaller the blocks are, the more fluid the display will be, but the rendering time will also be longer. The height and width of these square tiles corresponds to the number of pixels provided in this field.

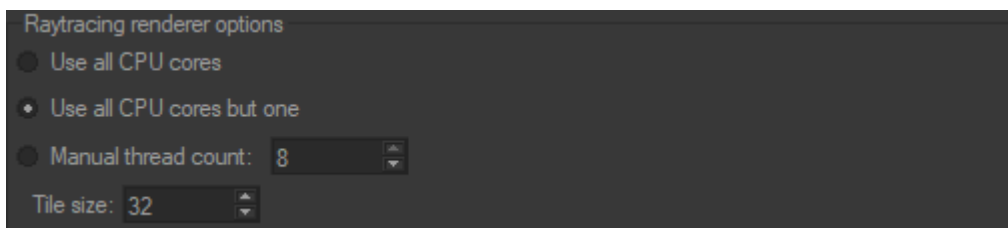

User Preset Tab

Patchwork 3D provides the ability to add your own preset values to certain lists in the interface.

Modifications to preset values are reflected in the list of presets as soon as they are entered. The preset lists are then saved in the Windows registry when you click **OK** and close the **Settings** editor.

Fresnel Value Presets

Used as shortcuts to load Fresnel values when setting up standard or multilayer materials, these values are listed by name in the preset list found in the **Reflection** tab of the **Materials** editor. You can access

this list by clicking on the  button next to the **Fresnel** values.

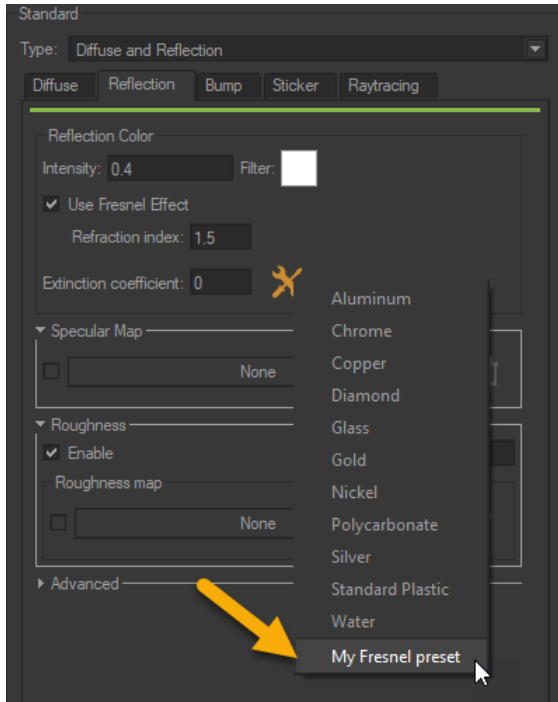

To create a new preset, click on .

To modify an existing preset, click on the corresponding line in the list of presets. Then, modify the **Name**, **Refraction** index, and **Extinction** coefficient values, or delete the preset by clicking on .

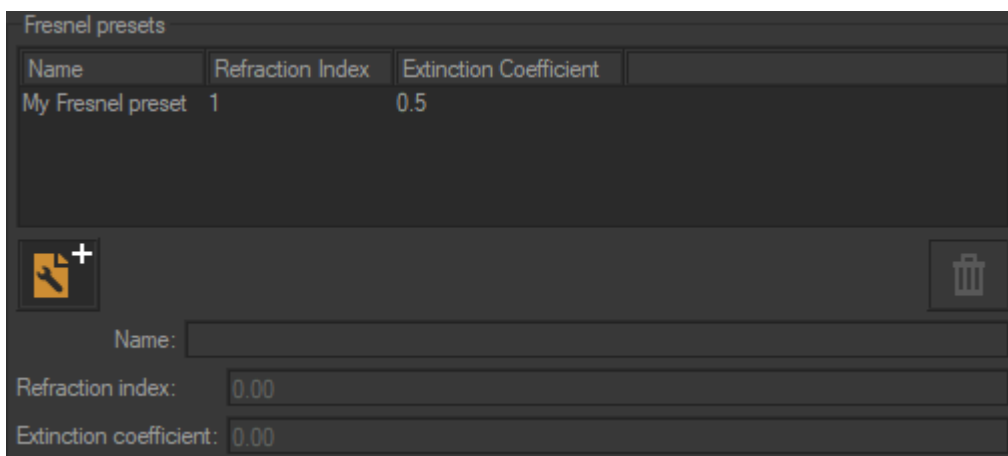

Deleting or modifying a Fresnel preset has no effect on the materials whose Fresnel values were initialized using a preset.

For additional information on the use of the Fresnel effect, see:

- Standard Material

Snapshot Dimension Presets

Used to define the size of a snapshot created with the **Snapshot** editors, these presets appear at the end of the list of available snapshot formats in any of the Snapshot editors.

To create a new preset, click on .

To modify an existing preset, click on the corresponding line in the list of presets. Then, modify the **Name**, **width**, **height**, and **units** (available for modification if you have ticked the checkbox **Defined with units**), or delete the preset by clicking on the  button.

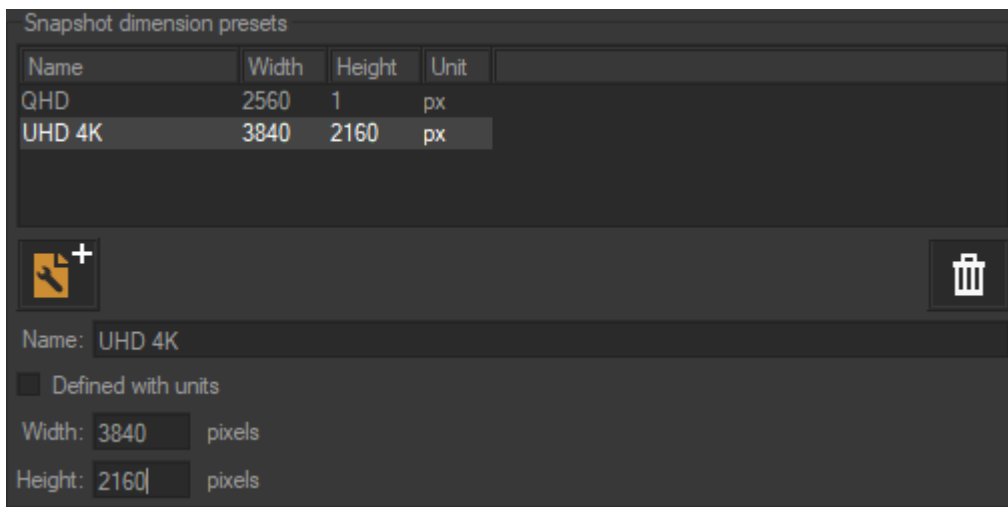

Deleting or modifying a snapshot dimension preset has no effect on snapshots added to the **Snapshot Batcher** whose dimensions were initialized using a preset. If the preset used was deleted or modified, the original values of the preset will be applied using the format **User-defined** or the format **User-defined with units**.

For additional information on snapshot dimensions, see:

- [Dimensions of the Media Output \[160\]](#)

Measurement Units

Patchwork 3D has numerical fields for physical lengths which show the unit the value is expressed in and allow it to be modified.

These measurement units are contextual parameters, so it is possible to use a different unit for each of the following categories:

- Geometry (shape of surfaces, placement in the scene, etc.),
- Geometric detail (various tolerances: stitching, etc.),
- Image (image size, screen size, etc.).



NOTE

The preferred unit for each category is recorded in the database.

SHAPER

This chapter describes the overall operation of the **Shaper** module.

Shaper Graphical Interface

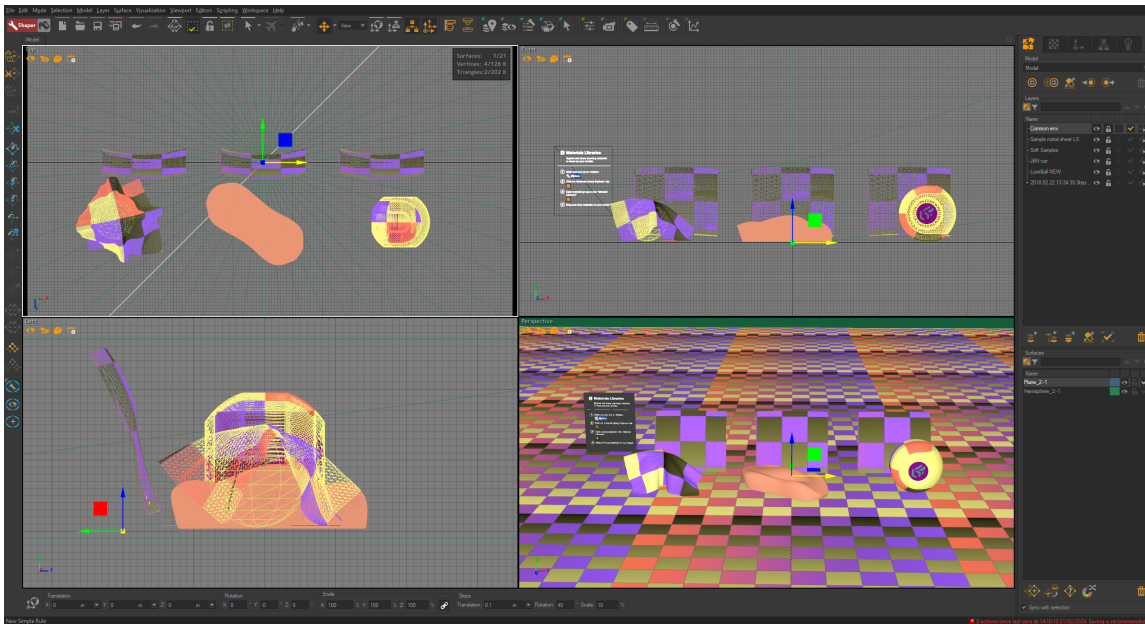

The **Shaper** interface is constructed around a system of interactive 3D views. By default, four views are displayed: the top, front and left views, configured in wireframe display, and a perspective view, configured as a solid display.

One of the four 3D views is active: it is surrounded by a zone displayed with highlighting (in the above image, the perspective view is active). In **Shaper**, the view-configuration options are applied by default to the active view.

Each view represents the 3D model that is being edited. Displaying a grid and the 3D view cube of the model helps you understand the orientation of these views. Each view displays the projection mode used in its upper left corner: front view, top view, back view, and perspective view.

Shaper provides you with several tools for modifying the point of observation and the viewing method used to represent the model in a 3D view: orbital movement about the model, viewing in wireframe mode or in solid mode, isometric or perspective projection, etc.

As in most of the applications, a menu and a toolbar located above the 3D views provide access to most of the functions of the application. On the right, a system of tabs gives access to the editing modes of **Shaper**: **Surface**, **Mapping**, **Pivot**, **Kinematics** and **Lighting**.

A vertical panel just below presents the tools available in each editing mode selected with the tabs. The above image shows the **Surface** editing mode of **Shaper** with the model, layer, and surface selectors.

Shaper Viewports

A 3D **viewport** is a rectangular window used to draw a 3D representation of the model that is being edited.

The representation of the model is determined for each viewport by a viewpoint (the position of the observer) and by a center of interest (the point being observed). Several types of representation exist: a wireframe 3D rendering gives a schematic vision of the model, whereas a surface 3D rendering gives a more real and more intuitive impression of the surfaces and volumes.

Shaper offers you four independent 3D viewports. The parameters of each viewport can be modified to facilitate the observation and editing of the model. One of the four viewports has a highlighted frame: this is the active viewport. The viewport configuration operations are applied by default to the active viewport. To activate a viewport, click on it with the left button of the mouse. By activating the **Viewport > Maximize Viewport** menu item, the active viewport is enlarged to fill the whole workspace. You can return to the four-view mode by deactivating the **Viewport > Maximize Viewport** menu item. This can also be done by pressing the **A** key.

In **Shaper**, you can work directly on the 3D viewports using the mouse. Several operating modes determine how the user can interact with the 3D environment with the mouse.

Configuring 3D Viewports

Shaper offers nine types of view.

These views are directly available in the viewport via the following icon  or via the menu **Viewport > Views** from the general menu.

View	Description
Perspective view	This type of view is similar to the objective lens of a photographic camera: the perspective deforms the surfaces as a function of the distance. An object viewed far away is represented smaller than an object that is close to the viewpoint.
Isometric view	Isometric views are used in industrial drafting: there is no perspective and the dimensions are not modified by the distance to the viewpoint.
Top view	This is an isometric view aligned on the axes of the model, showing the model viewed from the top. The camera is placed on the Y+ axis.
Bottom view	This is an isometric view aligned on the axes of the model, showing the model viewed from the bottom. The camera is placed on the Y- axis.
Left view	This is an isometric view aligned on the axes of the model, showing the model viewed from the left. The camera is placed on the X- axis.
Right view	This is an isometric view aligned on the axes of the model. The camera is placed on the X+ axis.
Front view	This is an isometric view aligned on the axes of the model. The camera is placed on the Z+ axis.
Back view	This is an isometric view aligned on the axes of the model. The camera is placed on the Z- axis.

View	Description
UVW Mapping view	This view shows the mapping coordinates of the model.

Interacting with the 3D Viewports



Shaper offers several operating modes for navigating in the 3D views.



NOTE

These interaction modes are available from the **Mode** menu.

Icon	Mode	Behavior	Shortcut
	Pan	Clicking and dragging in a 3D view allows you to slide the viewpoint in the plane of observation. The center of interest moves with along with the viewpoint.	Middle mouse button + drag the mouse
	Orbit	Clicking and dragging in a 3D view allows you to rotate the viewpoint about the center of interest. The position of the center of interest remains unchanged.	Ctrl+Middle mouse button + drag the mouse
	Zoom	Clicking and dragging in a 3D view brings the viewpoint closer to the center of interest, which has the effect of magnifying the objects located in the field of vision.	Shift+Ctrl+Middle mouse button + drag the mouse
	Zoom region	Clicking and dragging in a 3D view draws a rectangular region. When the mouse button is released, the view is centered on this region. The direction of observation is unchanged, but the viewpoint and the center of interest are moved in relation to the new centered view.	
	Camera Roll	This mode rotates the product relative to the center of the screen.	
	Lens Shift	This mode reproduces the behavior of a lens shift and makes it possible to display without distortion of the perspectives and with the same focal length, a composition that would not normally fit into the field of the Patchwork 3D camera.	

Icon	Mode	Behavior	Shortcut
	Fly Mode	<p>Can be used with a perspective view only.</p> <p>Once this mode is enabled, navigation is in fly mode, and by simply moving the mouse (without clicking), you can make the viewpoint rotate about the center of interest. A (continuous) left-button click or a (continuous) right-button click allows you to move forwards or backwards, which has the effect of magnifying the objects located in the field of vision. Click and dragging allows you to fly around the object.</p>	
	Walk mode	<p>Can be used with a perspective view only.</p> <p>When you enable this button, you go into walk mode, and moving the mouse allows you to rotate the viewpoint about the center of interest. Clicking and dragging gives you the illusion of walking (forwards or backwards) next to the object. Unlike Fly mode, in Walk mode, the altitude of the point of view remains constant.</p>	

The **Model > Zoom to Fit** menu offers several tools that facilitate centering of the views:

Zoom type	Description
Zoom selection to fit in active viewport	This modifies the center of the active view to view the selection in its entirety.
Zoom world to fit in active viewport	This modifies the center of the active view to view the model that is being edited, in its entirety.
Zoom selection to fit in all to viewports	This modifies the center of each view to view the selection in its entirety.
Zoom world to fit in all viewports	This modifies the center of each view to view the model in its entirety.

Configuring the Rendering in a 3D Viewport

The 3D rendering of the active view can be configured to modify the representation of the model that is being edited.





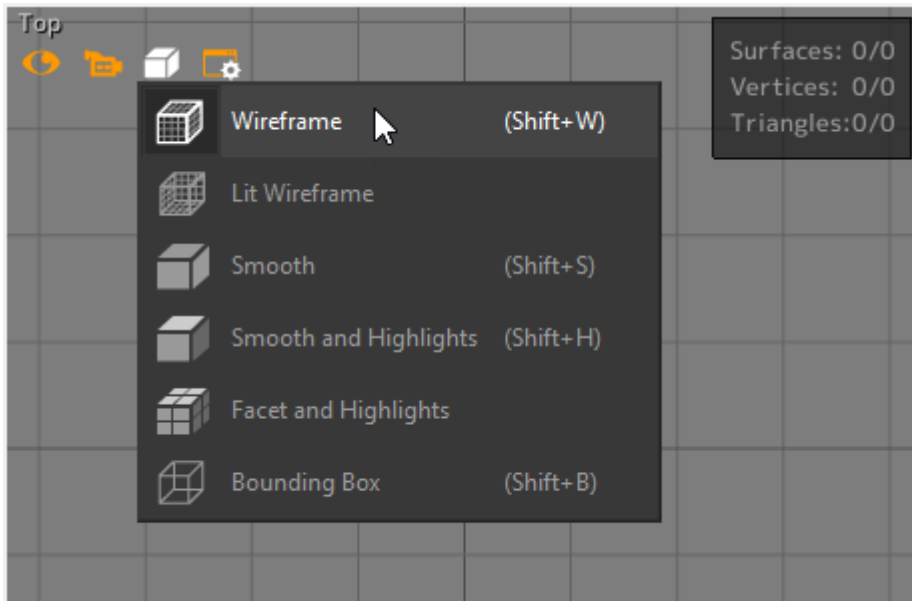

It can be accessed directly in the viewport or via the **Viewport** menu.

Directly from the viewport

You can change the representation of the model from the following icon  which is located at the top left of all viewports.



Seven rendering modes are available:

Icon	Render Mode	Description
	Wireframe	The surfaces are represented schematically with plotting following the lattice structure of each surface. The surfaces are not mutually masked.
	Smooth	The surfaces are shown smoothed out with solid faces, lit by soft lighting.
	Smooth and Highlights	The surfaces are shown smoothed out, as solid faces with a specular reflection.
		This is the default render mode.
	Facets	The surfaces are represented by their lattice structure, not smoothed out, as solid faces lit by soft lighting.
	Facets and Highlights	The surfaces are represented as a solid lattice structure, not smoothed out, as solid faces with a specular reflection.
	Lit Wireframe	The surfaces are represented by an illuminated wireframe plot of their lattice structure.
	Bounding Box	Each surface is represented by the wireframe plot of its bounding box. This rendering mode facilitates the handling of surfaces that have lattice structures comprising a large number of triangles.

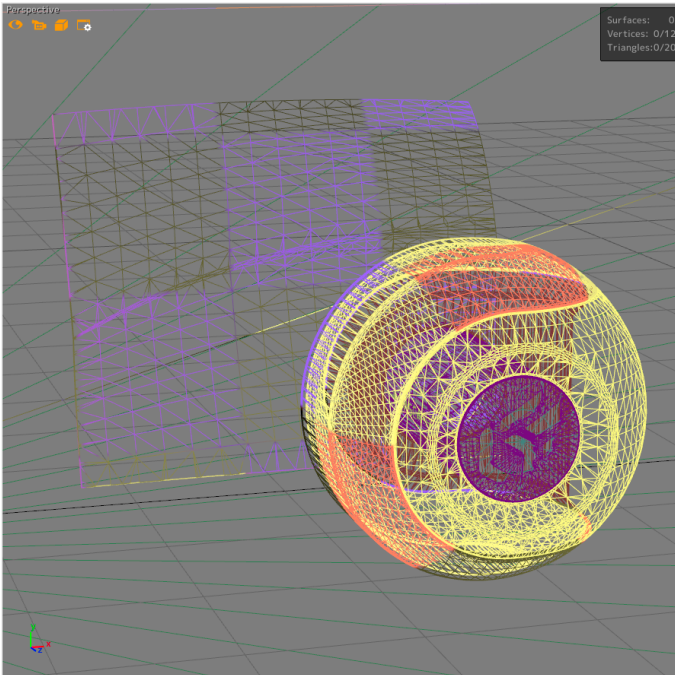

Wireframe view

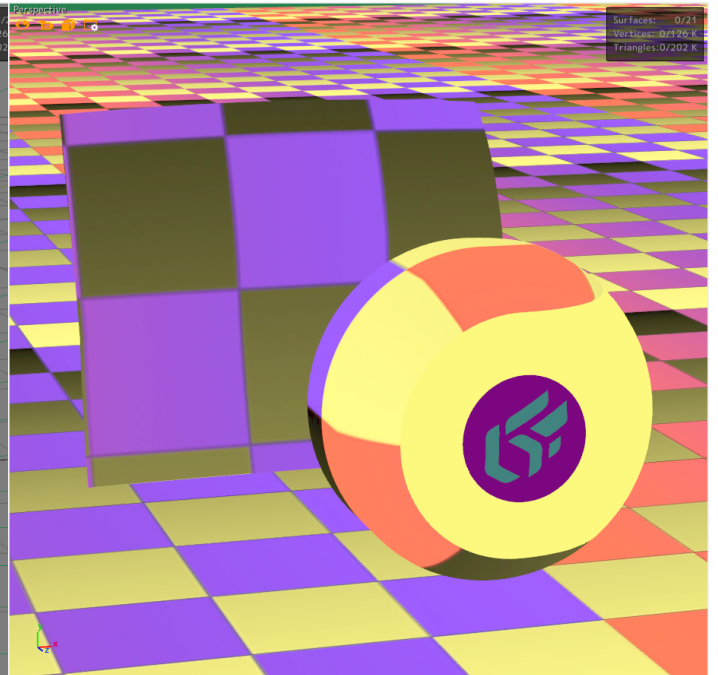

Smooth view

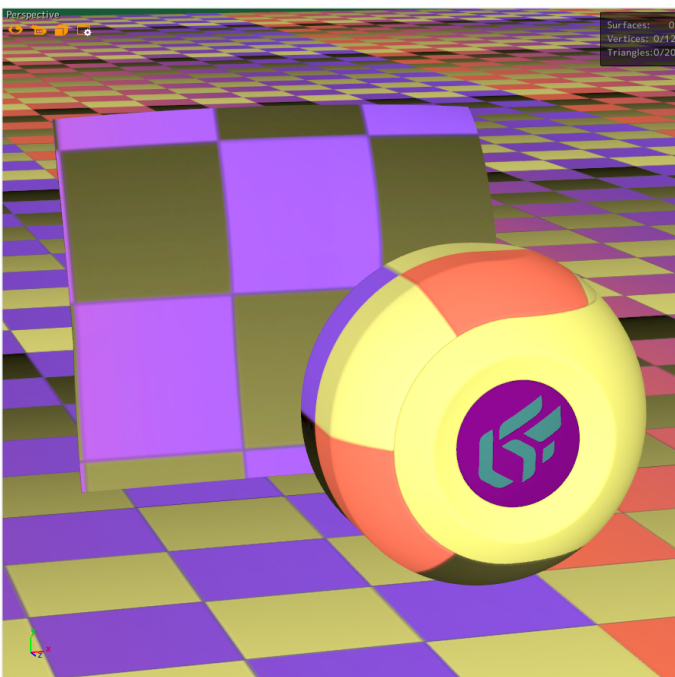

Facets and Highlights view

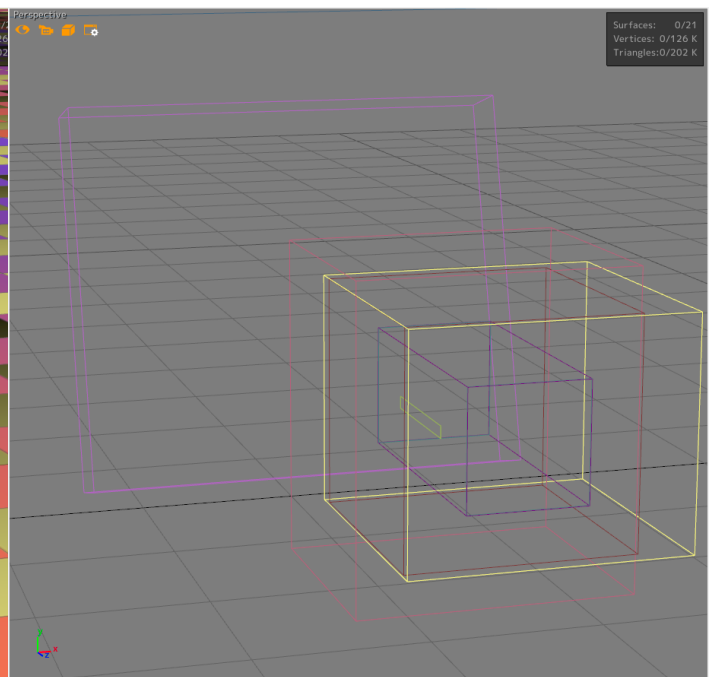

Bounding Box view

Several options for displaying your model are available from the following icon  which is located at the top left of all viewports.

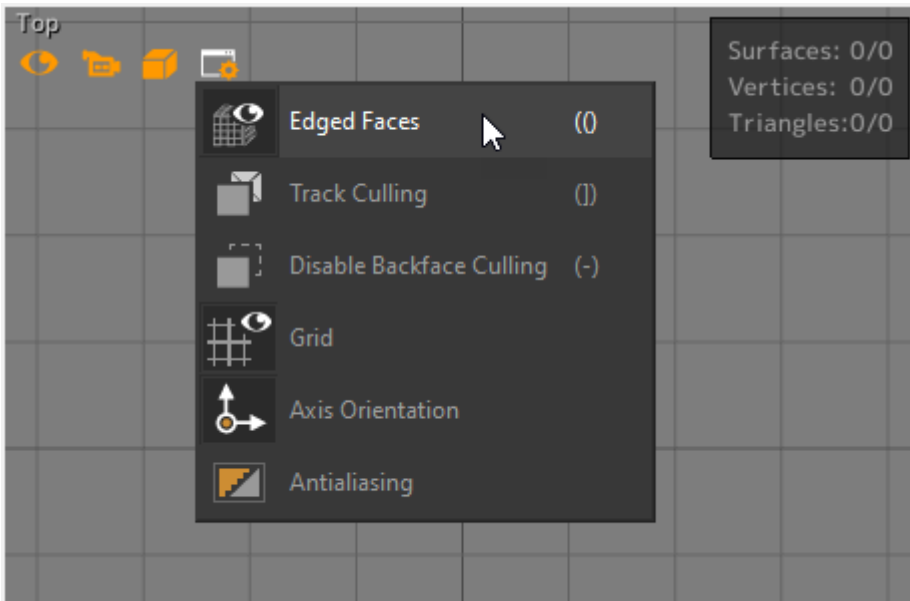

Option	Description
Edged Faces	The lattice structure of the surfaces is represented as a wireframe 3D rendering overlaid on the surfaces.
Track Culling	The hidden faces (oriented away from the observer) are shown in bright red. This mode facilitates the identification of the surfaces that are not properly oriented.
Ignore Backface Culling	Enabled by default, this option enables the optimization of the rendering, which removes the faces oriented away from the observer.
Grid	Displays a reference grid that facilitates understanding of the 3D viewport. The grid is enabled by default.
Axis orientation	Displays the indicator of the different axes for the model in the bottom left corner of the window. This option is enabled by default.
Antialiasing	The anti-aliasing improves the visual quality of the 3D rendering by deleting the aliasing effects caused by screen pixels. You have the possibility of modifying the anti-aliasing configuration in the Patchwork 3D rendering settings [60] .

Portion of image not antialiased With the antialiasing enabled

Demonstration of the smoothing produced by the antialiasing algorithm.

From the menus



The menu **Viewport** > **All Viewport Render** > **Render mode** gives access to the modes (**Wireframe**, **Smooth**, etc...) described in the previous section.

The accessible options from the **Viewport** menu are the same as those described in the previous section.

Other viewing aids are available from the **Visualization** menu as **Head Up Display** which displays the number of surfaces, triangles, and vertices selected in the viewport.

Selection Visibility Modes

Two options modify the behavior of **Shaper** for displaying a model that is being edited without affecting the attributes of the surfaces:

Icon	Option	Description
	Edit menu > Show Selected Only	<p>When this option is enabled, only the selected surfaces are visible. The selected surfaces are represented as unselected surfaces to facilitate viewing.</p> <p>The selection is locked to prevent errors: you can no longer modify the selection with the mouse. This mode is particularly helpful when it is necessary to isolate a subset of surfaces in a complex model: enable this option to momentarily isolate the selected surfaces and check the consistency of your selection. You can use the keyboard shortcut associated with this menu entry to quickly enable and disable this option (S key by default).</p>
	Edit menu > Shade Selected	<p>When this option is enabled, the selected surfaces are represented with smooth rendering in the views where you are using wireframe shading.</p>

Manipulating Shaper Objects

Selection

A selection is a group of surfaces designated by a user in the model being edited.

Selected surfaces are represented in a 3D viewport with green highlighting. One of the surfaces is designated as the leader. It is represented with white highlighting. The leader surface is used for various operations that require the identification of a single surface within the selection.

The **Shaper** interface offers three methods to modify the selection of surfaces:

- By selecting surfaces with the mouse directly from the graphic representation in the 3D viewport. This uses the **Selection [74]** mode.
- By enabling one of the operations affecting the selection from the menu or the toolbar.
- By using the surface selector that can be found in the layer selector in the **Surfaces** sidebar tab in **Shaper**.

Actions available from the context menu

Once you have defined a selection, you can use  **Freeze Selection**, available from the context menu that appears when you right-click in the viewport. The current selection will be locked. To keep you from modifying it and to make it easier to manipulate this selection, the tools for selecting and deselecting objects are deactivated until you unfreeze the current selection by selecting **Freeze Selection** again.



Still by right-clicking, the **Select a surface under cursor** lists the different types of selection:

- The **Advanced Selection Under Cursor** opens a window allowing you to select a surface under the cursor. This option is useful when a product has several overlapping surfaces.
- The saved selections. You can find them in the **Saved selections** tab of the **Selections (Editor)** [229].
- The surfaces under the cursor.

The context menu also allows you to resize the selected surface(s) with **Scale Gizmo** . Please refer to how the **scaling gizmo** [78] works to apply the transformation.

Modifying the Selection Using Menu Operations



Operations for modifying the selection are available in the **Selection** menu:



Icon	Function	Description
	Select All	Select all the surfaces of the model.
	Invert Selection	Invert the selection: select all unselected surfaces and deselect the surfaces that were previously selected.
	Select None	Deselect all surfaces.
	Selection by type	Select surfaces by type.
	Selection by lighting	Select surfaces with or without lightmaps.

Surface Selector

The surface selector is placed under the layer selector in the **Surfaces** panel of the **Shaper** sidebar. It shows the list of surfaces associated with the current active layer. Each surface is represented by its name and three boxes characterizing its state: **visible**, **frozen**, or **selected**.

The color of the first box corresponds to the color of a surface in the 3D viewport.

The second box corresponds to the visibility of the surface. An eye  represents the visibility of the surface. When the eye is barred and grayed out , the surface is not visible.

The third box indicates whether the surface is frozen or not. This condition is represented by a lock . When the lock is closed and red , the surface's selection state is locked. It cannot be selected or deselected.

The fourth box corresponds to the surface selection. When the checkmark is highlighted in white, the surface is selected. A green checkmark indicates that the tessellation for the selected NURBS surface can be modified.

At any moment, you can modify the state of a surface by clicking on the boxes.

A few operations are directly accessible from the surface selector via the icons and the options menu. To open the options menu, place the mouse pointer on the designated surface and right-click on it.

When an operation is called up directly from the surface selector, it applies to all the surfaces that are highlighted in the surface selector.

You can mark or unmark a surface with a **Ctrl**-click on its name in the surface selector. You can extend the marking to other surfaces by **Shift**-click on their names. You can cancel the marking by clicking in the selector outside the surfaces.

Certain operations are available from the selector's context menu.

At the bottom of the surfaces selector, tools allows you to duplicate the marked surfaces, to send the marked surfaces to the active layer, to call up the properties box for the marked surfaces, or delete the marked surfaces.

You can move the marked surfaces to another layer with a drag and drop of the marked surfaces to the destination layer.

By clicking on one of the column headers of the surface selector, you can modify the sorting used for displaying the surfaces: sorting by name or sorting by box.

Selection Mode



Operation mode **Select**  (**F2**) allows you to interact directly on 3D surfaces to modify the selection. However, other ways of influencing selection exist. Please refer to the section on [the selection \[72\]](#) for more information.



Function	Shortcut
Select a single surface	Click on the surface.
Add a surface to the selection	Shift + click on the surface.
Remove a surface from the selection	Ctrl + click on the surface.
Cancel a selection	Click anywhere in the background of a viewport.

By holding the mouse button down and moving the mouse cursor, you plot a rectangular region. When you release the mouse button, all the surfaces that are visible in this region are included in the selection operation.

Function	Shortcut
Select all surfaces in a region	Click and drag the mouse pointer in the viewport.

Function	Shortcut
Add all surfaces in a region to the selection	Shift + click and drag the mouse pointer in the viewport.
Remove all surfaces in a region from the selection	Ctrl + click and drag the mouse pointer in the viewport.
Cancel a selection	Click anywhere in the background of a viewport.

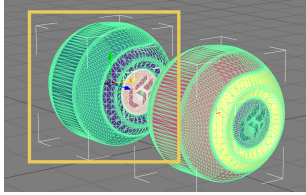
The different selection methods are as follows:

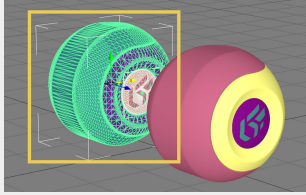
Icon	Function	Description
	menu Selection > Touched by Region (F3)	By default, the selection system is configured to designate all the surfaces contained or partially contained in the designated region during the click and drag.
		
	menu Selection > Enclosed by Region (F4)	Only the surfaces that are fully contained in the region are designated during the click and drag. This operating mode is particularly advantageous when you wish to designate the surfaces of a more complex assembly.
		

Icon	Function	Description
	Selection menu > Restrict Region To Visible	Only visible surfaces contained in the region are selected when clicking and dragging. This procedure is particularly useful to avoid accidentally selecting surfaces hidden by other surfaces.



NOTICE

This selection mode works in conjunction with the other two selection modes **Touched by Region** and **Enclosed by Region**.

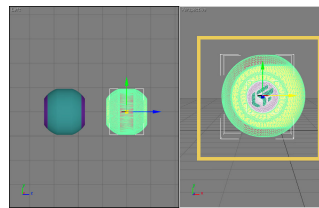

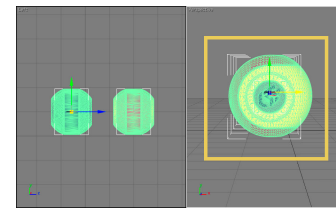

Restrict Region to Visible enabled



Restrict Region to Visible disabled

Manipulating Surfaces

Gizmos

Patchwork 3D includes gizmos that make it easier to manipulate 3D objects in space. They appear automatically as an overlay on the selected as soon as the gizmo of **Translation** , **Rotation**  or **Scale**  is enabled.

To move an element along an axis, click the part of the gizmo that represents the movement axis and drag the mouse in the desired direction. To rotate an element, the movement axis is either up-down or left-right. The farther you drag the mouse along this axis, the greater the angle of rotation will be.

The operation is the same for both types of movement (translation and rotation) and for scaling:

- If it is a single selection, the movement or scaling will be done in its transformation frame.
- If it is a multiple selection, two options are possible depending on the chosen mode:
 - each modification (movement or scaling) will be done in the leader's frame,
 - each modification (movement or scaling) will be done in its own frame.



TIP

When you hold down the **Alt** key, the selected element moves at a preset pitch. The value of this pitch can be customized (see the section on setting step values in the chapter [Positioning Surfaces from the Main Interface \[79\]](#)).

A numerical indicator placed close to the gizmo shows the value applied to transformation in real-time.

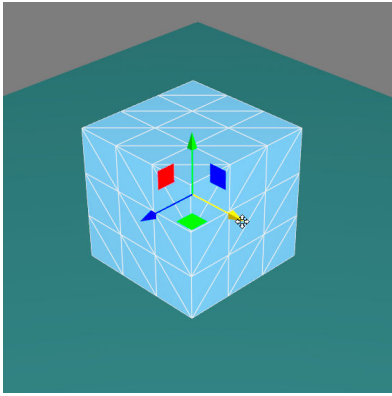

Translation movement

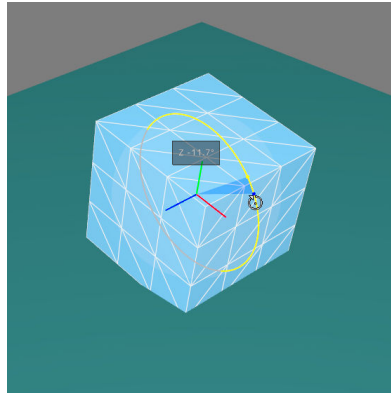

Rotation movement

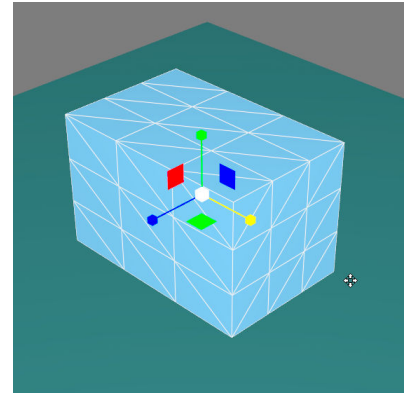

Scaling

Translation

The **translation gizmo**  lets you move surfaces by clicking + dragging on the selection.

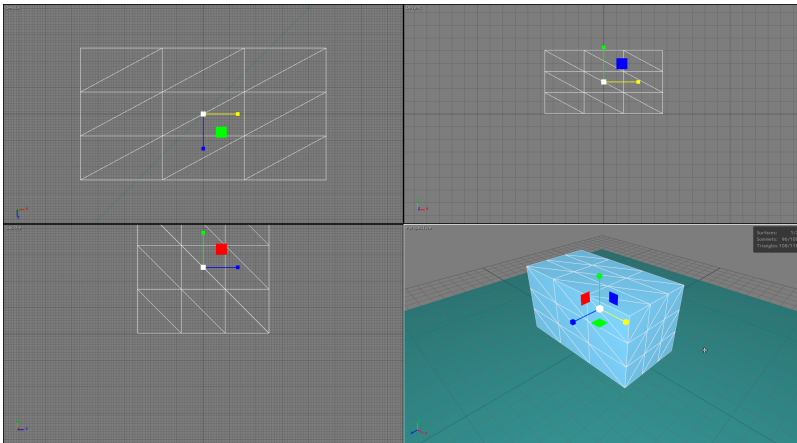

Translation Gizmo.

Rotation

The **rotation gizmo**  allows the orientation of surfaces to be modified by clicking and dragging the selection. This operational mode works similarly to the **translation gizmo**: you can modify the selection with the same mouse and keyboard combinations.

When the mouse is moved along an axis (up-down or left-right), the selected surfaces rotate around one of the axes of their referential.

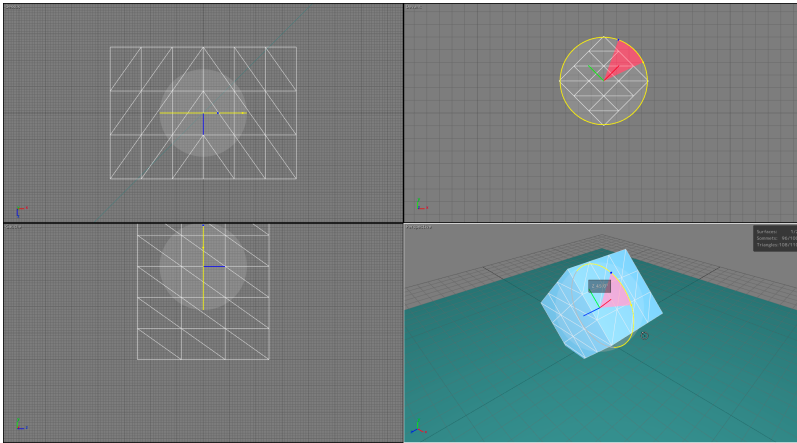

Rotation Gizmo.

Scaling

The **scaling gizmo**  allows you to resize the selected surfaces by clicking + dragging on:

- the axis of the gizmo, the resizing of the surfaces will then be constrained to the selected axis (X, Y, or Z).
- the plane of the gizmo, the resizing of the surfaces will then be constrained to the selected plane (horizontal, vertical, transverse).
- the central cube, the resizing of the surfaces will be uniform on the 3 axes at the same time.

A surface is moved in relation to its transformation referential. The center of the referential is placed over the surface's pivot.

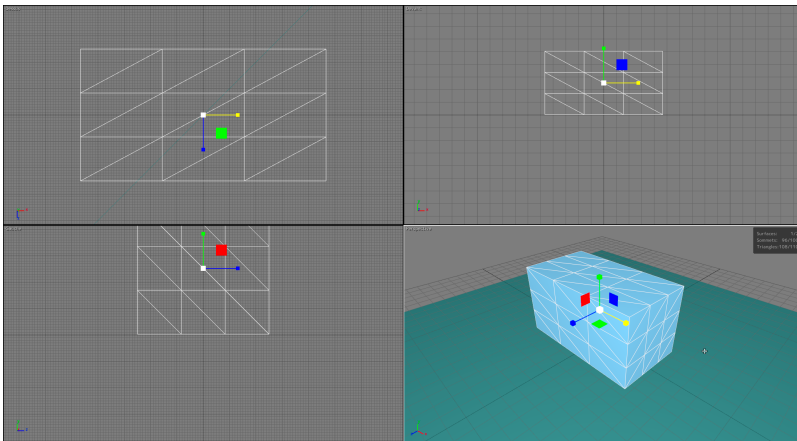

Translation Gizmo.

Transformation Tools



The drop-down menu in the top toolbar establishes the transformation referential and contains four options: **Screen**, **View**, **World** and **Local**.

Referential option	Description
Screen	The transformation referential is aligned with that of the screen on the XY plane. Moving a surface in XY occurs on a plane parallel to the screen and passing through the surface's pivot.
View	For orthographic views (top, bottom, left, right, front, and back), the behavior is the same as for the Screen orientation. For isometric and perspective views, the behavior is the same as the World orientation.
World	The transformation referential is aligned with the axes of the model.
Local	The transformation referential is aligned with the local referential of the surface. In this mode, the transformation referential is identical to the pivot [284] .

Moving a surface occurs in three dimensions along the transformation referential, although the cursor is moved on the plane of the screen in two dimensions. The movement of the mouse is therefore not sufficient to determine the 3D movement of a surface. This is why moving a surface is limited to one or two selected dimensions via the transformation referential.

Surface Visibility and Frozen States

Shaper provides three operating modes that allow you to quickly modify the visibility and the frozen state of surfaces:

Icon	Function	Description
	Click to Hide	Click on a surface to hide it.
	Click to Freeze	Click on a surface to freeze it.
	Click to Unfreeze	Click on a surface to unfreeze it.

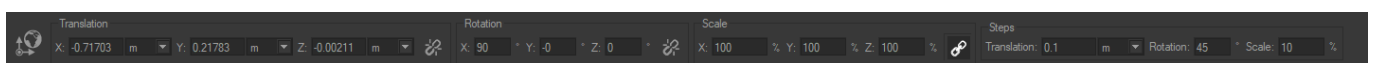

Positioning Surfaces from the Main Interface

Patchwork 3D includes an area in its interface specifically for editing the positions of surfaces. This editing area is beneath the 3D viewports in the workspace. It allows for directly entering numerical values for the position of surfaces relative to axes X, Y, and Z.



Editing area dedicated to surface positioning.

The toggle button **Enable user input for absolute coordinates**  in the toolbar is for displaying or hiding this editing area. Entering numerical values for these parameters is only possible when a surface is selected.

The toggle button **Keep Ratio**  of the **Scale** box affects the scaling behavior of selected surfaces. You can indeed choose to keep the same dimensions on all axes (X, Y, and Z) and to have a uniform scaling  or on the contrary choose not to have a uniform scaling on the three axes (X, Y, and Z) . Here you will find explanations on how the [scaling \[78\]](#) works.

Coordinates in World Reference Frame

The **Translation** and **Rotation** boxes are for specifying the surface's translation coordinates (TX, TY, and TZ) and the rotation orientation (RX, RY, and RZ) of the selected surface's pivot relative to the World frame. The selected surface remains fixed relative to its own pivot.

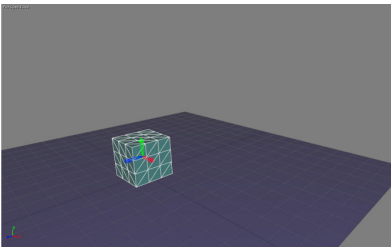

Initial position of the cube's pivot.

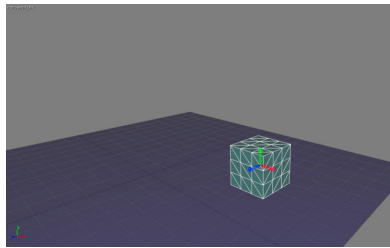

Intermediate position of the cube's pivot after entering coordinates TX=0.5 m and TZ=-0.3 m.

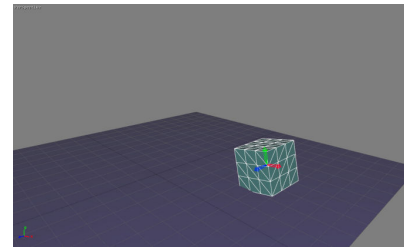

Final position of the cube's pivot after entering angular coordinate RZ=10°.



NOTE

In the **Pivot** mode, translation and rotation tools affect pivots only instead of affecting surface-pivot couples, which they do in the other modes.

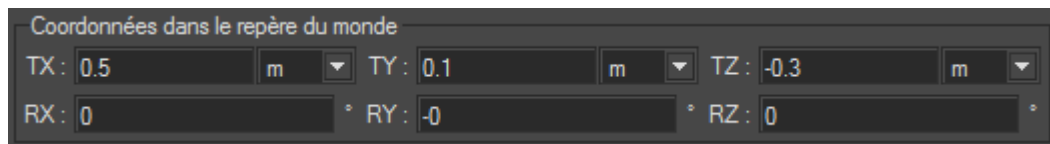

Coordinates in the World Reference Frame for the final position of the pivot shown in the previous figure.

Coordinates Relative to Parent's Pivot

The **Translation** and **Rotation** boxes are for specifying the position coordinates (TX, TY, and TZ) of the pivot's origin and the angular coordinates (RX, RY, and RZ) of the pivot for the surface selected relative to the pivot of its parent in the kinematics chain.

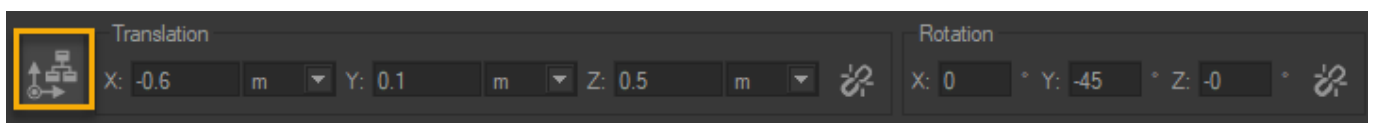
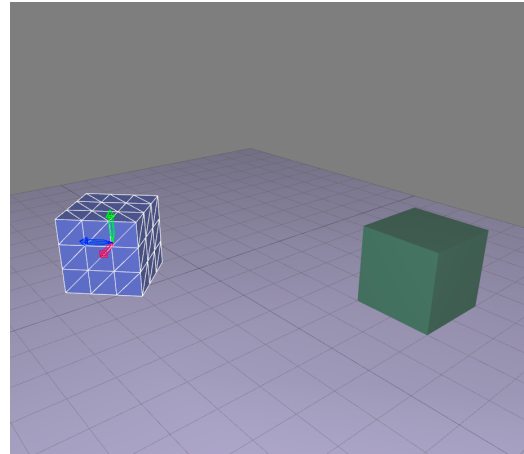
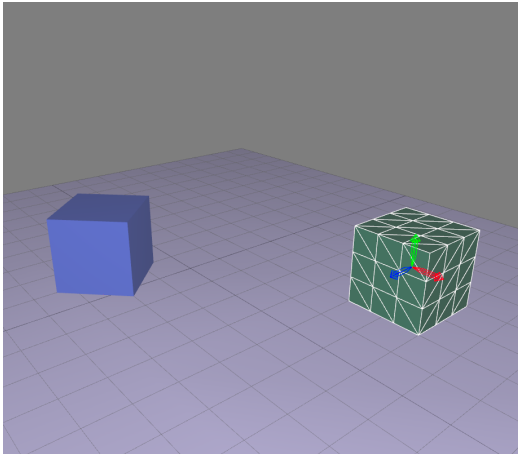

Positioning the blue cube's pivot relative to the parent surface's pivot, the green cube's.

When no parent is defined for the surface selected, the values entered are considered to apply to coordinates in the world frame reference like in the first box.

Relative Translation and Rotation

The function **Enable user input for relative rotation or translation**  may be accessed only when either the **Translation** or **Rotation** gizmo is activated. It displays the **Relative translation** or rotation dialog box.

The value by which the surface selected is translated relative to the frame of the gizmo displayed is entered in fields TX, TY, and TZ. The value by which the surface selected rotates relative to the axes of the frame of the gizmo. The frame of the gizmo depends on the frame of reference selected.

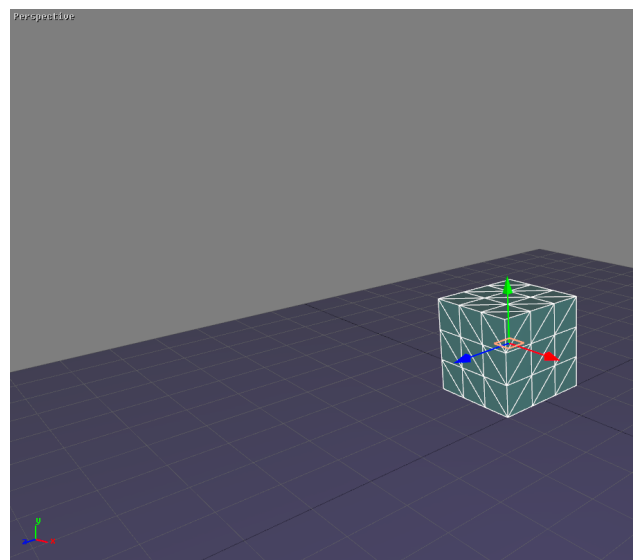
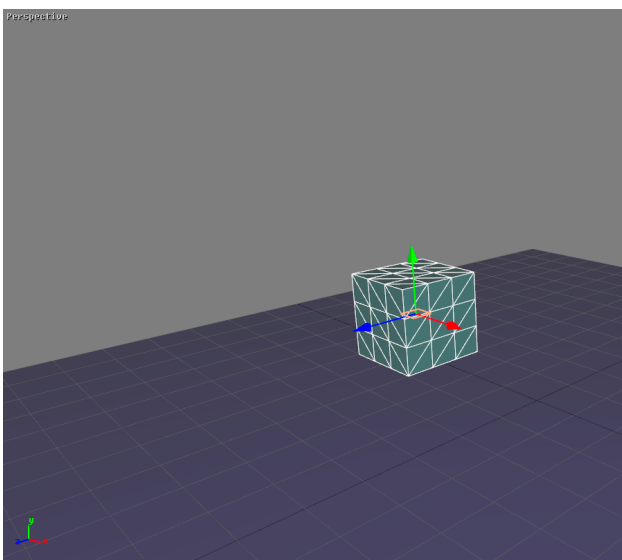

The cube's translation gizmo origin is located at $X = -0.4$ m (on the left). A translation of 0.3 m in the direction of the World frame's X axis is applied to the cube (final position on the right).

Applying a Transformation to a Selection of Surfaces

Two modes exist to apply a transformation to a selection of surfaces:

Transform selected surfaces regarding the pivot of the leader of the selection : the transformation is applied to all selected surfaces relative to the selection leader (displayed in white).

Transform selected surfaces regarding their own pivot : the transformation is performed for each surface relative to its own pivot.

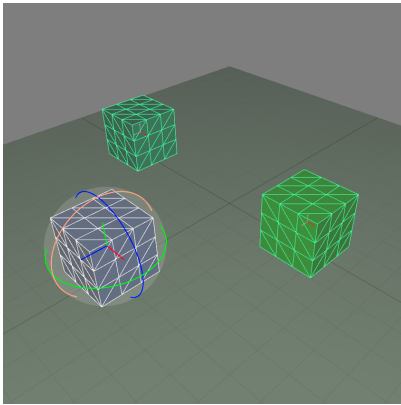

A selection of surfaces. The selection leader is displayed in white.

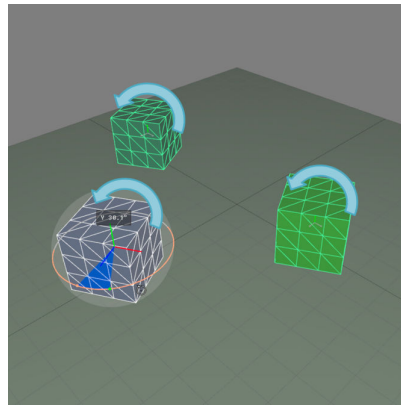
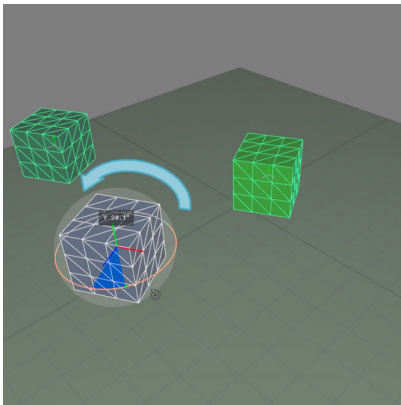

Rotation applied to the surface selection presented in the previous figure relative to the selection leader's pivot (left) and relative to the surfaces' individual pivot (right).

Defining the Step Values

The box on the right side of the area dedicated to positioning surfaces allows users to define fixed increments of movement or rotation for using the gizmos while holding down the **Alt** key.

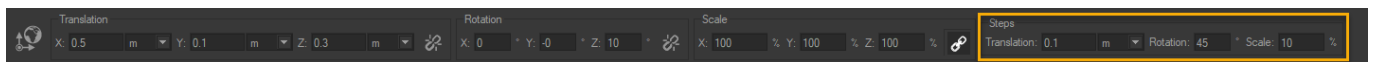

Steps box for specifying the step values (outlined in yellow).

Alignment tool

This tool allows you to simply align selected objects in Shaper.

Depending on the number of objects to align, the alignment method differs slightly. Here are some examples of alignment.

Aligning objects to a reference object

1. Start by selecting the objects to align.
2. Click the icon  in the toolbar of **Shaper**.
3. In the alignment tool window that opens, activate the mode **Select from viewport** then click the **Select** button.

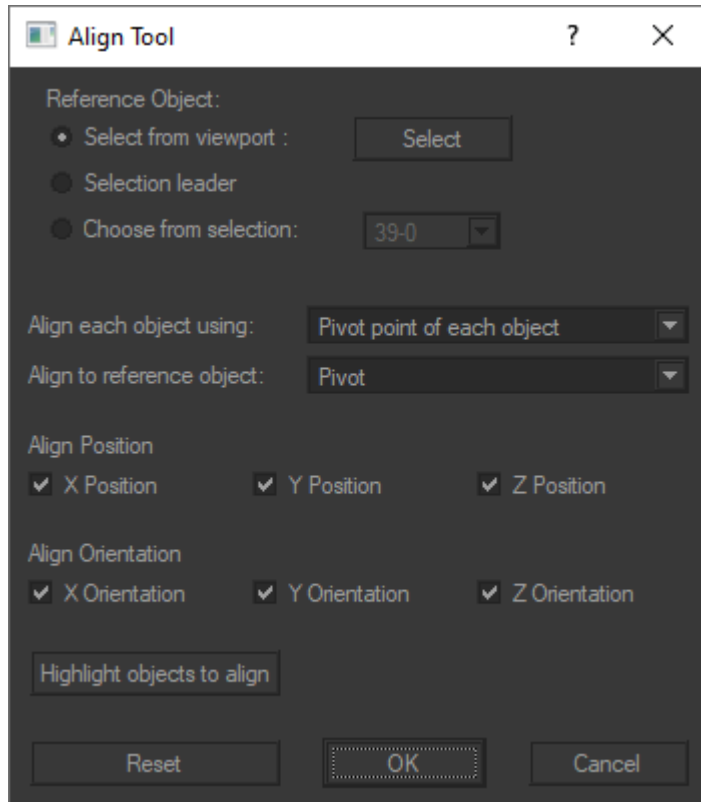

4. Select the reference object to which the objects should align.
5. In the small window that appears, then click the **Apply selected object as reference**. The reference object is added as a leader to the Shaper selection and is highlighted with white color.
6. Come back to the **Alignment tool** and choose parameters from the following: **Pivot point of each object** or the **Center of each object** to determine how the alignment of objects will be achieved. Then choose **Pivot** or **Center** of the reference object B on which object A must align. Use the coordinates **X**, **Y**, and **Z Position** and **Orientation** alignment.



NOTE

The button **Highlight objects to align** makes it easier to identify objects to align in a complex model, even if you interrupt the alignment procedure by accidentally clicking on another object. This button helps you quickly find the objects you want to align, by highlighting them in your model.

To use it, just click on it. The objects to be aligned will then be highlighted, allowing you to resume the alignment procedure quickly and easily.

7. To finish, click the button **OK** to apply the alignment of object A to object B.

Aligning multiple objects to the leader object

1. Start by selecting the objects to align with each other.



TIP

The last object added to the selection will have the status of leader. If we select objects A, B, and C, it's the object C that will have the status of leader because the selection was made in this order: object A > object B > object C.

Selected surfaces are represented in a 3D viewport with green highlighting. One of the surfaces is designated as the leader. It is represented with white highlighting. The leader surface is used for various operations that require the identification of a single surface within the selection.

2. Click the icon  in the toolbar of **Shaper**.
3. In the alignment tool window that opens, select the option **Select leader**.

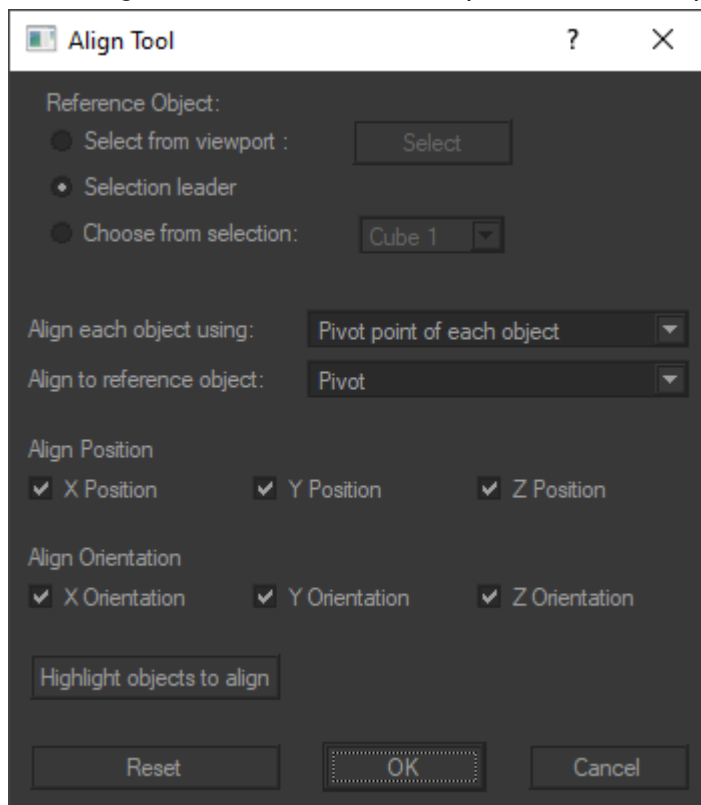

4. Choose from the following: **Pivot point of each object**, **Pivot of the leader of the selection**, **Center of each object**, or **Center of the selection** to align objects A and B with object C. Select how the alignment should be done with the **Pivot** or the **Center** of the reference object C on which object A and object B must align. Use the coordinates **X**, **Y**, and **Z Position** and **Orientation** alignment.



NOTE

The button **Highlight objects to align** makes it easier to identify objects to align in a complex model, even if you interrupt the alignment procedure by accidentally clicking on another object. This button helps you quickly find the objects you want to align, by highlighting them in your model.

To use it, just click on it. The objects to be aligned will then be highlighted, allowing you to resume the alignment procedure quickly and easily.

5. To finish, click the **OK** button to apply the alignment of objects to the leader.

Aligning multiple objects by selecting the leader object in the selection

1. Start by selecting the objects to align with each other.
2. Click the icon  in the toolbar of **Shaper**.
3. Select the reference object from the drop-down list in the Alignment Tool window that opens. It will serve as a reference for aligning other objects.

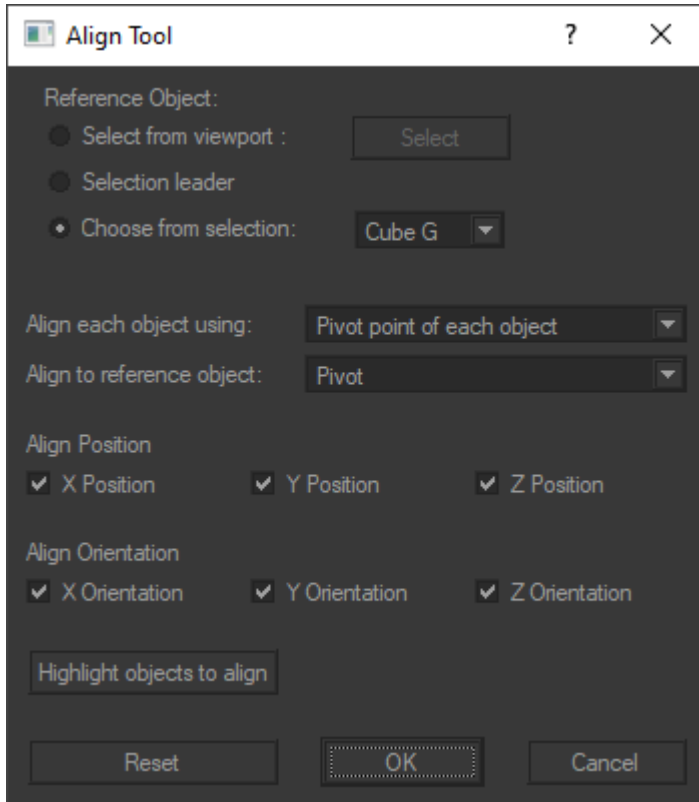

4. Choose from the following: ***Pivot point of each object***, ***Pivot of the leader of the selection***, ***Center of each object***, or ***Center of the selection*** to align objects. Select how the alignment should be done with the ***Pivot*** or the ***Center*** of the reference object. Use the coordinates ***X***, ***Y***, and ***Z Position*** and ***Orientation*** alignment.



NOTE

The button ***Highlight objects to align*** makes it easier to identify objects to align in a complex model, even if you interrupt the alignment procedure by accidentally clicking on another object. This button helps you quickly find the objects you want to align, by highlighting them in your model.

To use it, just click on it. The objects to be aligned will then be highlighted, allowing you to resume the alignment procedure quickly and easily.

5. To finish, click the button ***OK*** to apply alignment to objects.

Explode View Helper

This tool allows you to create an animation of an exploded view from a selection of surfaces and a selected vector. For this, it is necessary to have a reference vector and to select the objects to explode.

1. Click the icon  in the **Shaper** toolbar.
2. Choose the type of animation for the exploded view: Linear or Radial.
3. In the tool window that opens, click the **Create and select** button to create a vector and select it. Using the [object manipulation gizmos \[76\]](#), move the vector in the desired direction. The origin of the vector will be the starting point for the animation of the exploded view. Its direction will be the same as that of the animation and its length will correspond to the distance from the furthest object that we want to see at the end of the animation.

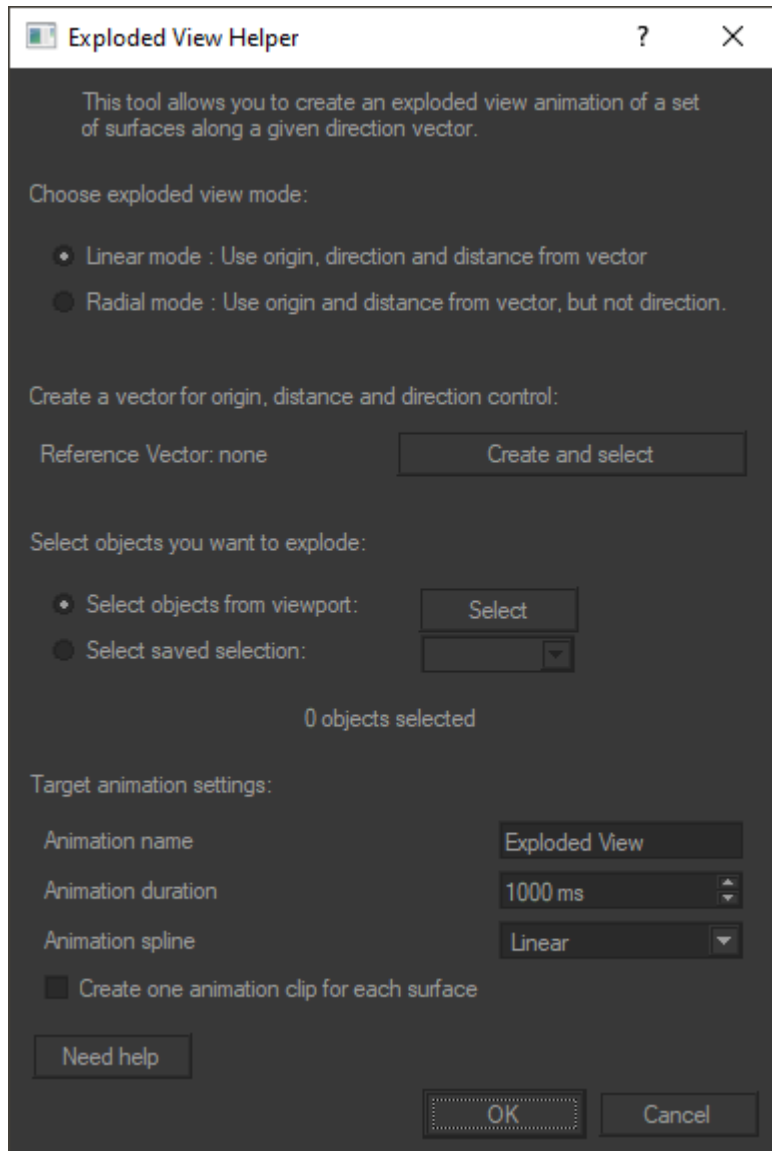

4. Then select the objects to explode either directly in the viewport of **Shaper** or from the drop-down menu which lists the object selection(s) that have been previously defined in the editor [Selections \(Editor\) \[229\]](#).
5. Then set the name, duration, and [animation type \[0 \]](#) (linear, jump, etc...) for the animation of the exploded view.
6. Click the OK button to create the animation.
7. In the **Matter** module of Patchwork 3D, open the  **Timelines** editor specifically the [Channel Clip Library \[141\]](#), and drag and drop the animation of the exploded view that has just been created into the **Timeline** named **Channels**.

You can now view the animation of the exploded view.

MATTER

This chapter describes the overall operation of the **Matter** module.

Matter Graphical Interface

Matter is designed on the multi-document application model. It manages the simultaneous editing of several products. These products are accessible via tabs.

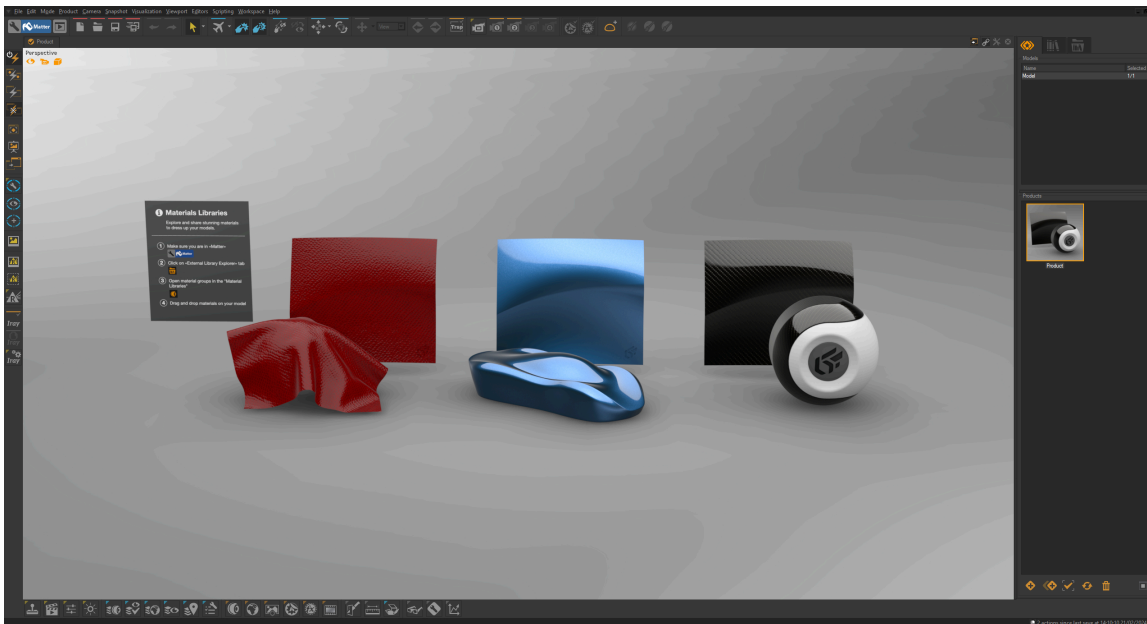

The graphic interface of **Matter** is organized into three functional zones:

- **Menu/Toolbar**: Visual regrouping of the various operations that are available according to the concepts handled.
- **Workspace**: Region receiving the various views.
- **Sidebar**: Organization of the tools in tabs.
 - **Product** tab: This tab is specialized for managing geometry and data. It also contains the product library.
 - **Library** tab: This tab groups together the libraries containing the visual elements used in developing a product. These elements can be edited and managed from their respective libraries.

The **Library** tab consists of seven libraries presented as sub-tabs: **material**, **texture**, **environment**, **background**, **overlay**, **post-processing** and **sensor**.



This is the core of **Matter**: it is here that the textures and materials are created.

- **Explorer** tab: This tab allows you to explore external libraries and to import the materials, textures, backgrounds, environments, overlays, post-processing blends and sensors saved on your computer or in other locations external to the open P3D database.

Collision Detection System

The collision detection system in **Matter** enhances the immersive experience when observing 3D scenes. When a scene is explored using either **Walk** or **Fly** modes, the collision detection system prevents the observer from passing through surfaces.

Collision detection includes two functions: **Collisions** and **Prevent Collisions with Transparent Surfaces**.

Icon	Function	Description
	Collisions	This function disables the passing of the camera through the surfaces of the scene during its movement. The camera is deflected along the surfaces.
	Prevent Collisions with Transparent Surfaces	This function is available only if Collisions mode is enabled. It modifies the effects of the Collisions function by allowing the camera to pass through the transparent surfaces of the scene.

Matter Viewports

In **Matter**, a viewport is a movable window confined in the workspace. The number of viewports is not set. You create them as needed by loading products in the workspace by drag-and-drop. A viewport enables you to interact with the product or products that you are editing. Each viewport consists of a list of tabs for rapidly selecting an open product, and a large interaction and viewing zone. Like in the **Shaper** module, **Matter** viewports can be maximized. To do so, use the tools in the top right corner, as in Windows.

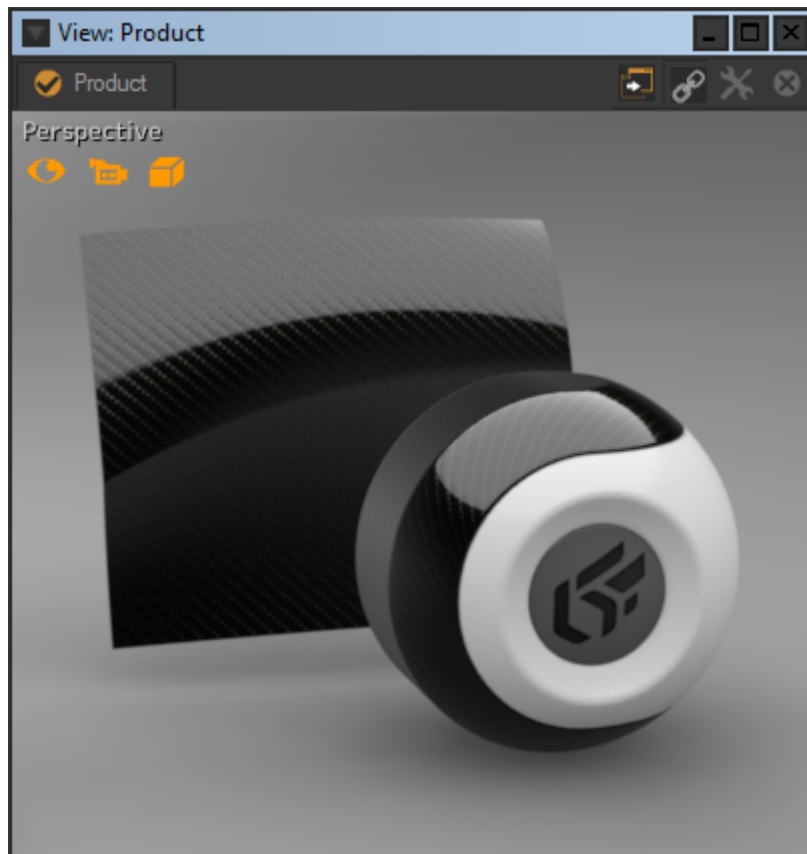

Importing an Object into the Active Viewport

The viewport is your means of editing a product. You can easily create viewports by:

- Dragging and dropping a model onto the workspace.
- Dragging and dropping a group of products onto the workspace.
- Double-clicking on a product.
- **Ctrl** + dragging and dropping a model onto a viewport.
- **Ctrl** + dragging and dropping a group of products onto a viewport.

They can also be created using the product tabs in an existing viewport by:

- **Ctrl** + dragging and dropping a tab onto another viewport.
- Dragging and dropping a tab onto the workspace.



TIP

Shift+Ctrl + dragging and dropping maximizes the new viewport in the workspace. **Ctrl** + dragging and dropping cancels the maximization of the current viewport and creates a new viewport.

Similarly, tabs in a viewport are created by:

- Double-clicking on a product in the Matter sidebar's product library.
- Dragging and dropping a model onto the interaction zone. The **Matter** module will automatically create a new product.
- Dragging and dropping a product selection onto the interaction zone.

To select the product to be edited (active product), simply click on a tab, and to delete it, click on the close tab  button.

When closing the last tab associated with the product (a product may be present in several viewports), the **Matter** module captures a representation of the product and updates the product's thumbnail image in the sidebar.

Interacting with the 3D Viewports



NOTE

These interaction modes are available from the **Mode** menu.

Matter has several interaction modes:

Icon	Mode	Behavior	Shortcut
	Pan	Clicking and dragging in a 3D view allows you to slide the viewpoint in the plane of observation. The center of interest moves with along with the viewpoint.	Middle mouse button + drag the mouse
	Orbit	Clicking and dragging in a 3D view allows you to rotate the viewpoint about the center of interest. The position of the center of interest remains unchanged.	Ctrl + Middle mouse button + drag the mouse
	Zoom	Clicking and dragging in a 3D view brings the viewpoint closer to the center of interest, which has the effect of magnifying the objects located in the field of vision.	Ctrl + Shift + Middle mouse button + drag the mouse
	Camera Roll	This mode rotates the product relative to the center of the screen.	
	Focal Angle	This mode is similar to the zoom ring on a photo lens: it changes the field of view. The more the lens is opened, the smaller the product appears. If you approach too close to an object, it disappears.	Shift + Middle mouse button + drag the mouse
	Lens Shift	This mode reproduces the behavior of a lens shift and makes it possible to display without distortion of the perspectives and with the same focal length, a composition that would not normally fit into the field of the Patchwork 3D camera.	
	Fly Mode	As soon as this mode is enabled, navigation is in fly mode, and by simply moving the mouse (without clicking), you can make the viewpoint rotate about the center of interest. Clicking and holding down the left or right mouse buttons allows you to move forwards or backwards, respectively, which has the effect of magnifying the objects located in the field of vision. Click and dragging allows you to fly around the object.	
	Walk mode	When this mode is enabled, moving the mouse allows you to rotate the viewpoint about the center of interest. Clicking and dragging gives you the illusion of walking (forwards or backwards) next to the object. Unlike Fly Mode , in Walk Mode , the altitude of the point of view remains constant.	
	Head Mode	When this mode is enabled, moving the mouse (without clicking) allows you to make the world turn around the point of view.	

Some of these modes (**Flight, Walk, Focal Angle**) can only be used with a camera with a perspective view.



TIP

The shortcut **Ctrl + Spacebar** centers the camera by positioning the point on the surface below the cursor at the center of the viewport.

**TIP**

The reframing operation **Zoom to fit (Z)**, in the **Camera** menu positions the point of observation in order to view the product as a whole while at the same time maintaining the direction of observation.

Configuring the Rendering in a Viewport

The viewport context menu allows you to choose the type of view in the **View** submenu.

In the submenu **Render**, you have access to the eight render modes.

The **Render Presets** allow you to activate one of the three default modes, **Default**, **Fastest**, and **Nicest**. If you choose, you can also define a new render preset to have it added to this menu for easy access.

Linking the Updates of the 3D Viewports

Accessible from: **Matter : Viewport > Link**

To facilitate the comparison of products spread among separate viewports from the same viewpoint (interactive comparison), the **Matter** module has a viewpoint synchronization mechanism. Thus, when the viewpoint of the active viewport changes, the other views are informed and can update their viewpoint under certain conditions:

Icon	Type of link	Description
	None	No updating of the point of view between viewports.
	All	Update all viewports to correspond to the point of view in the active viewport.
	Model	Update all viewports containing products based on the same model. This way, all of the products obtained from that model are observed at the same angle.
	Link Interactively	Enabled by default, this mode allows synchronized viewports to be updated while you are interacting with them. However, for very heavy scenes, this interactive synchronization is detrimental to the smoothness of movement. When this option is disabled, synchronization is possible only at the end of a phase of interactive manipulation.

Grid and Axis Orientation

A grid of a set size serves as a reference and can help improve the understanding of volumes within a 3D viewport. This grid is available under **Visualization > Grid**.

Similarly, a reference icon illustrating the placement of the axes in the direction of observation is available under **Visualization > Axis Orientation**.

Render Statistics

The  **Render Statistics** are available from the **Visualization** menu.

This option displays data related to rendering delays, the number of surfaces, summits, and triangles processed, and the GPU memory used.

The consumption of GPU memory is displayed as a gauge for the following elements:

- The images and videos used as **textures** and rendered in the active viewport,
- The **meshes** rendered in the active viewport,
- The textures used to calculate relief (**bumpmaps**) that are rendered in the active viewport,
- The lighting **environments** rendered in the active viewport,
- The **lightmaps** calculated in **Shaper** and used during the rendering in the active viewport,
- **Other**: other sources of GPU memory consumption, including database resources that are not used in the active viewport, other open software, and the memory reserved by the graphics card's driver,
- **Free**: unused GPU memory.

Full Screen Mode

Accessible in: **Matter** : **Visualization** > **Full Screen Mode**



TIP

Keyboard shortcut **Y**

The **Matter** module has a **Full Screen** mode. In this mode, the viewing and interaction zone of the active view occupies the maximum amount of space available for the Windows applications.

The interface of Patchwork 3D is no longer accessible, but the floating editors maintain their visibility and their position.

As the tabs are no longer visible, product selection is performed via the **Next tab in active viewport (S)** and **Previous tab in active viewport (Q)** operations.

Floating Viewport of Matter



Available in : **Matter**: **Visualization** > **Floating Mode**

In **Matter**, click on the **Undock the viewport**  button on the upper right corner of the viewport to detach the viewport and use it as a floating window. All its interest lies in the fact that it stills visible in **Shaper**. You could use **Matter's** viewport on a monitor and **Shaper** on another if you have, for example, a two-display workstation.

The interest of **Matter's** floating viewport is multiple.

- Such as doing an unfolding with the **Unfolding/Stitch Workshop** from **Shaper** and checking, for example, that your unfolding in **Matter** meets your requirements.
- Create a scene by moving multiple geometries in **Shaper** and interactively checking in **Matter** the result.

You will have understood that the limits of creation are only limited by your imagination.

Click the button again  to dock the floating viewport of **Matter**. The floating viewport of **Matter** will automatically dock into **Matter** module accessible from this icon .



TIP

Matter's keyboard shortcuts are also accessible in the floating viewport of Matter, even if you are in **Shaper** module. However, not all editor features are supported.

Modifying Default Properties

Click on the **Viewport Properties**  button at the top right of a viewport to modify the viewport properties. This opens the editor for **Viewport Properties**.

By default, clippings planes are visible in viewport according to the settings used in the **Clipping Planes** [208] editor. This behavior corresponds to the **No override** property.

You can force clipping planes to be **enabled** or **disabled** in this viewport by selecting the desired option from the drop-down list.

Unlinking from the Shaper Configuration

Click on the **Link Configuration**  button at the top right of a viewport to enable or disable the configuration link to **Shaper** for this viewport.

By default, the configuration in each **Matter** viewport is linked to the configuration in **Shaper**. The configuration in each viewport is not independent.

When linked to the **Shaper** configuration, this viewport will show the current configuration for geometry layers, position layers, and lighting layers as set in **Shaper**. When this viewport is modified, it will change the configuration in **Shaper**. Any modifications to the configuration displayed in **Shaper** will be shown in this viewport when you return to **Matter**.

If multiple viewports are linked to the **Shaper** configuration, changing the configuration for geometry layers, position layers, or lighting layers in one of the viewports will cause the same change in all other viewports linked to the **Shaper** configuration.

Viewport Rendering Modes

Patchwork 3D offers eight rendering modes.

These rendering modes are accessible via the following icon  of the viewport.

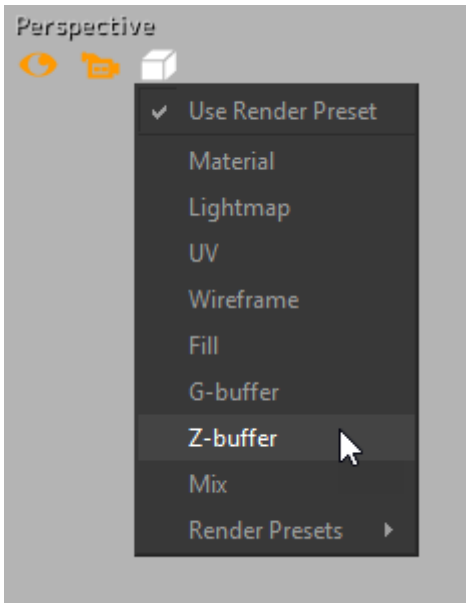

The **Material** mode displays a rendering of the **Matter** materials.

The first modes, **Wireframe**, **Fill**, **UV** and **Lightmap**, provide a view in **Matter** of certain **Shaper** elements: tessellation, Shaper colors, mapping UV coordinates, and lightmaps textures, respectively.

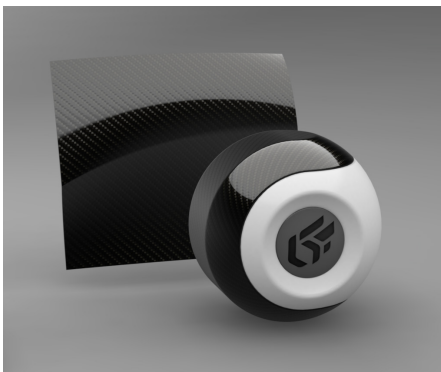

Material rendering



Fill rendering

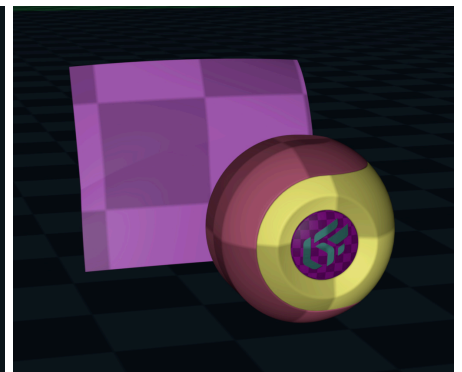

UV rendering



Lightmaps rendering

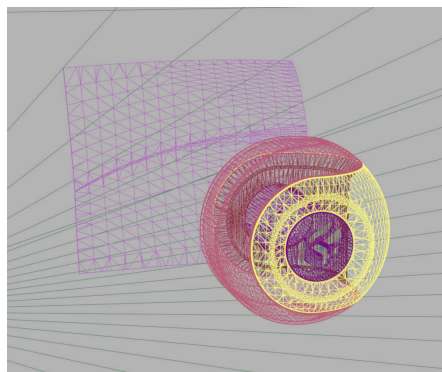

Wireframe rendering

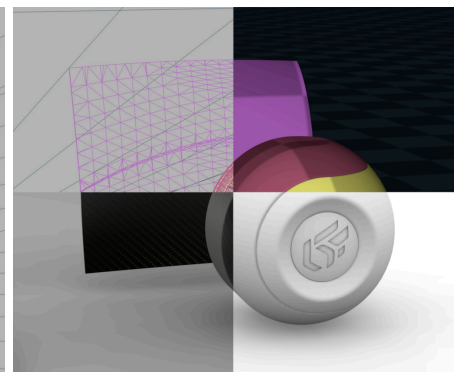

Mix rendering

The **Mix** mode displays a mix of all of the previous modes.

The **Z-buffer** and the **G-buffer** are used to view the Patchwork 3D scene by showing the positioning of the objects relative to one another and the distinction of the elements by surface group.

G-buffer is a viewing method for quickly discerning the various elements of a 3D scene by representing them as single-color tones.

Z-buffer is a viewing method making it easier to understand a 3D scene by using the information relating to the depth level of the objects.

This view shows the various elements of the scene with respect to the viewpoint, in greyscale. The closest objects are shown as lighter than the distant objects.

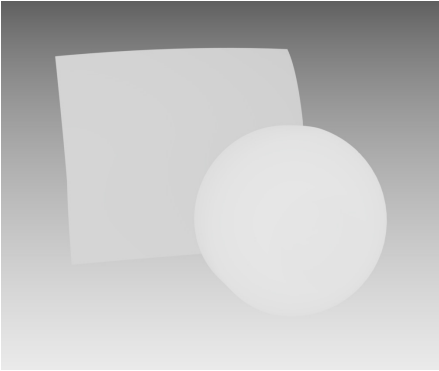

Z-buffer rendering mode.

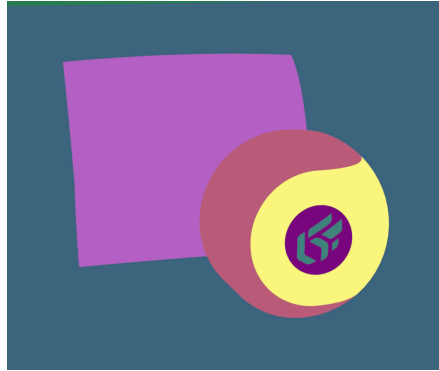

G-buffer rendering mode



NOTE

In the G-buffer rendering mode, the color used to represent an object is the color that has been assigned to the group of surfaces of this object in **Shaper**.

By combining these rendering modes with the post-processing effects, you can obtain many interesting visual effects.

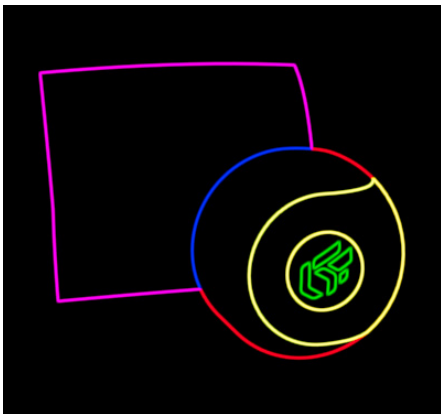

G-buffer rendering + "Edge detector" post-processing.

Managing Matter Resources







Dragging and Dropping Matter Resources

You can add materials files (.kmt), environments (.hdr), images (.jpg, .png, etc.), to the Patchwork 3D libraries by drag and drop.

Purging Unused Matter Resources

Patchwork 3D includes tools for permanently deleting unused resources. This allows you to optimize the size of your Patchwork 3D files.

These tools take the form of buttons in the toolbars of the various Matter resource libraries in the sidebar.

Icon	Description
	Permanently delete unused materials.
	Permanently delete unused textures.
	Permanently delete unused backgrounds.
	Permanently delete unused environments.
	Permanently delete unused overlays.
	Permanently delete unused post-processing blends.
	Permanently delete unused sensors.

Listing Matter Resources

This function will inform you of all of the products in which a resource is used.

This function is available via the context menu for each resource. In the corresponding sidebar library, right-click on the resource (material, texture, background, etc.) and select **Usage List** to display the list of products in which the resource is used.

Purging Unused GPU Resources

Accessible in: **Matter : Edit > Purge Unused GPU Resources**

When products are opened in **Matter**, each of them consumes GPU resources even if the product is not currently being modified. Materials, textures, backgrounds, environments, overlays, and post-processes are stored in the memory. Closing a product's viewport will free up the GPU resources assigned to this product.

Another means of freeing GPU resources while keeping multiple products open in viewports is to use the

Purge Unused GPU Resources option by simply clicking the corresponding button  located in the **Edit** menu in **Matter**.

External Library Explorer

This sidebar tab allows you to load and filter materials, textures, backgrounds, environments, overlays and post processes from your local hard drive or network drive.

By default, the external library points to the `C:\Program Files\Lumiscaphe\Patchwork 3D 2026 X8 release 1\Library` directory where you will find samples of materials and environments for your use. This directory is organized into several sub-folders: **Backgrounds**, **Environments**, **Materials**, **Overlays**, **Postprocesses**, and **Textures**.



NOTE

Each file format is filed away in its category, i.e. the material files are filed under the **Material** tab, etc.

It is possible to add one or more external libraries to **Matter** by clicking on the following icon . For example, you could add a personal library with your own content or add another shared on the network with your collaborators.

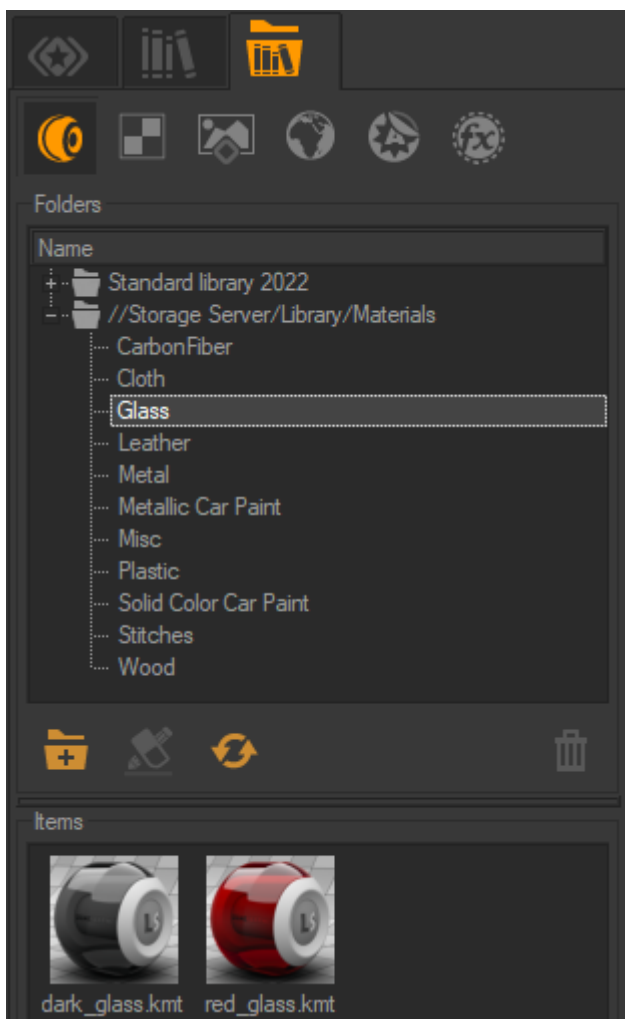

Example of adding an external library hosted on a server.

**NOTE**

When adding a new library, Patchwork 3D may ask you to create subfolders when the software detects that they are missing. We recommend that you let Patchwork 3D create them for you (cf. **Create the missing subfolder(s)**). A library is only recognized by Patchwork 3D if it contains the sub-folders mentioned earlier in this chapter.

If a subfolder is missing from the library, right click on the missing resource and select **Repair library path**, then indicate to Patchwork 3D the root of the external library. The software will then ask you to create the missing subfolder, click on **Create the missing subfolder (s)** to correct the warning .

To facilitate their identification, you can give an alias to the name of each of your external libraries by clicking on . The directory name will not be changed.

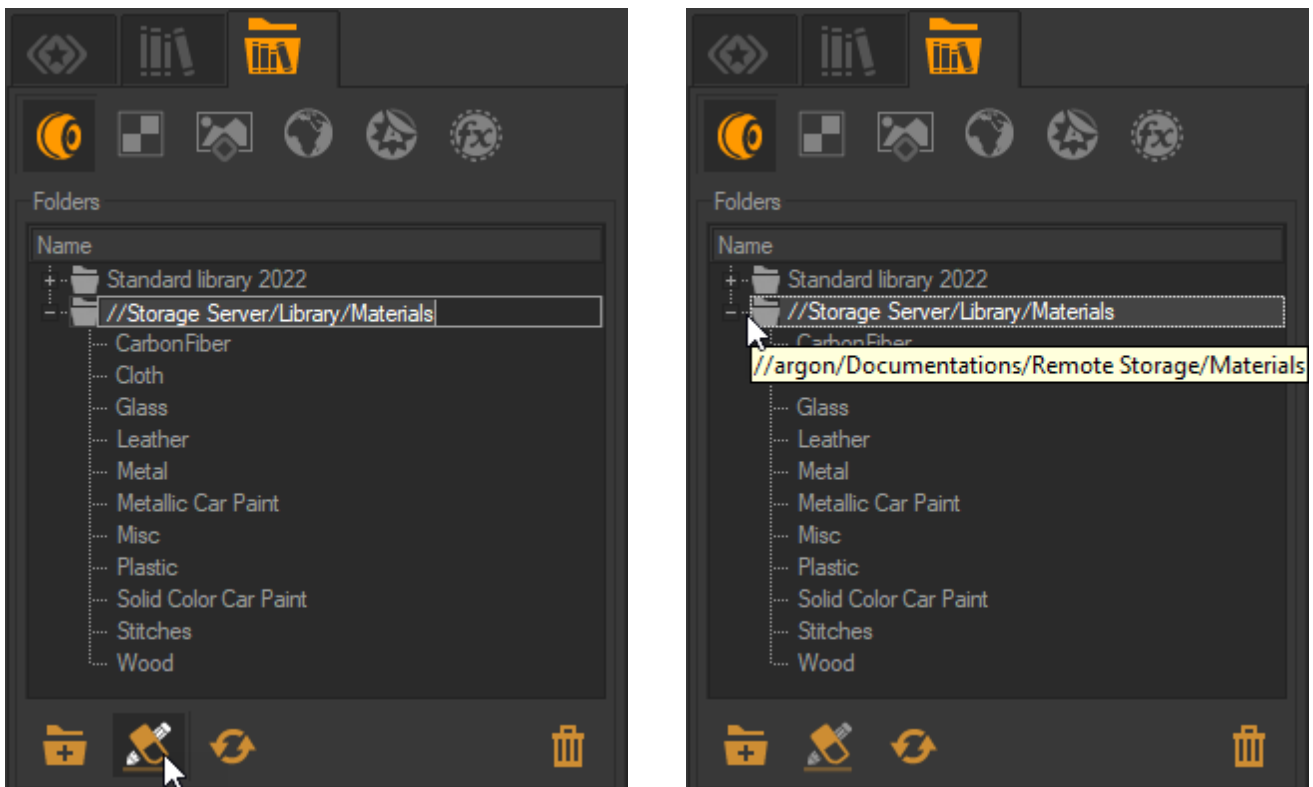

Example of adding an alias to an external library.

From the explorer you can drag and drop elements such as backgrounds onto a product in a viewport. This background will be automatically added to the already-existing library of backgrounds in the open P3D database.

EDITORS









In this chapter, you will find below the list of Patchwork 3D editors.

List of Editors in Patchwork 3D



NOTICE





All the features described below may not be present in your software edition: Community, Premium, Essential, or Enterprise.

Editor	Shaper	Matter	Usage
 Camera Animations [106]		✓	available via the Timelines editor,
 Backgrounds [112]		✓	assembles settings associated with the aspect of 2D backgrounds
 Surface Cutting Workshop [130]	✓		contains advanced surface cutting tools
 Unfolding & Stitch Workshop [114]	✓		contains advanced surface flattening (unfolding) tools
 Timelines (Editor) [135]		✓	creates animation sequences called "timelines"
 Aspect Layers [143]		✓	manages layers containing color and material information, as well as saved groups of aspect layer visibility settings
 Position Layers [147]	✓	✓	manages layers containing modified positions for the geometric objects in the model, as well as their visibility; object positions in the layers can only be modified in Shaper
 Cameras [148]	✓	✓	manages the hierarchical camera list, the favorite cameras for each product, and the settings of the camera currently being edited
 Channels [154]		✓	available via the Timelines editor; sets up an animation of almost any parameter related to a product's aspect

Editor	Shaper	Matter	Usage
 Sensors [159]		✓	contains the settings associated with sensors, including the assignment of backgrounds, overlays, and post-processing
 Snapshots (Images) [160]		✓	prepares and creates image files from Patchwork 3D rendering
 Configuration Keys [175]		✓	available via the Timelines editor; sets up the animation element allowing the visible configuration to be changed
 Animation Sliders [175]	✓	✓	allows animated meshes and geometry animations associated with translation vectors or rotation axes, as well as timeline clips, to be played back manually, one by one
 Configurations [176]	✓	✓	defines the display rules for layers and groups them into product configurations
 GPU Consumption [178]	✓	✓	analyzes GPU consumption and detects ways it can be reduced
 Product Environments [183]		✓	manages lighting environment layers and environment properties per product (orientation, setup for use with the real-time sun)
 Tag Manager [186]	✓		creates tags and assigns them to objects or groups of objects
 Import Log	✓	✓	displays the status (events, warnings, and errors) of an import
 Gradients [188]		✓	available via the Materials editor; creates or imports gradients
 HDR Light Studio (plug-in) [243]		✓	creates or modifies a lighting environment with HDR Light Studio
Imported File History	✓		lists files that have been imported into the model currently being edited
 Rendered Views History [192]		✓	provides a history of snapshots that have been rendered with Patchwork 3D
 Text Image [194]		✓	creates an image based on text, which can then be used as a texture
 Materials [196]		✓	contains settings associated with the aspect of materials

Editor	Shaper	Matter	Usage
 Live Mode [197]		✓	creates associations between a click on a specific surface and a channel animation clip or a timeline, for playback when Live mode is enabled
 Configuration Browser [199]	✓	✓	allows a user to explore configurations set up for a product
 VR Objects [160]		✓	prepares and creates VR objects
 Measuring Tool [200]	✓	✓	measures the distance between two points in the 3D space
 Panoramas [170]		✓	prepares and creates 360-degree panoramic videos from Patchwork 3D rendering
 Cubic VR Panoramas [160]		✓	prepares and creates VR cubic panoramas from Patchwork 3D rendering
 Raytracing Settings [204]		✓	establishes the settings used by the raytracing engine
 Advanced Triangulation Parameters	✓		allows minimums and maximums to be applied to the calculation of surface tessellation (a CAD import license option is required)
 Clipping Planes [208]		✓	positions, displays, and modifies the display settings of the clipping planes that bisect a product
 Post-Processing [211]		✓	contains the settings for a series of 2D post-processing effects, from effect-specific settings to the order in which effects are applied
 Database Properties [214]	✓	✓	contains information concerning the color profile and the origin of the file
 Viewport Properties		✓	can require a specific display behavior for clipping planes in the corresponding viewport
 Model Properties	✓	✓	displays and can edit the name of the model and the display size for nulls

Editor	Shaper	Matter	Usage
 Product Properties [223]		✓	displays and can edit the name of the product, the disassociation of Shaper and Matter visibility states, and the rendering policy for backfaces
 Surface Properties [218]	✓		provides information on the surface or object and manages associated options
 Surface Properties [221]		✓	contains aspect properties (material, stickers, specific lighting environment) for a surface, by aspect layer and by environment layer
 Environment Properties [214]		✓	contains settings associated with a lighting environment, including its orientation and its alternate background texture
 Keyboard Map [224]	✓	✓	lists and can modify keyboard and mouse shortcuts used in Patchwork 3D
Render Quality Settings [225]		✓	defines render mode presets in the viewport and contains tools to limit, if necessary, extensive calculations during interaction with the scene
 Snapshot Batcher [200]		✓	assembles rendering tasks for creating videos, images, VR objects and VR panoramas for which immediate rendering was not selected, and runs batched rendering
Color Chooser [231]	✓	✓	available in any editor where a color choice is possible; contains a color selection widget and means of managing a color palette
 Selections [229]	✓		contains advanced selection tools, including selection by type, selection by search, and saved selection groupings
 Layer Visibility Bookmarks [234]	✓	✓	saves and calls up visibility states for geometry layers and for surfaces
 Layer Visibility [241]		✓	displays and can modify the visibility state of each individual geometry and lighting layer
 Real-Time Sun [235]		✓	adds a sun-type lighting that can be set up and modified in real time
 Stereo		✓	modifies the basic stereoscopy settings when the stereoscopy mode is enabled

Editor	Shaper	Matter	Usage
 Overlays [240]		✓	contains the settings associated with the aspect of overlays
 Textures [241]		✓	manages image, resolution, and color properties for textures
 Triangulation	✓		manages the interactive tessellation of a NURBS surface or group of NURBS surfaces (a CAD import license option is required)
 Videos [160]		✓	prepares and creates video files from a timeline

Camera Animations (Editor)

Available in: **Matter** : **Timelines** > **Camera Animations** library tab > double-click on an animation name

Timelines > **Camera** track > double-click on a clip

Camera Animations is an editor that allows you to set up a camera animation by defining a camera path. You have a choice between three different types of camera path:

- **Kam File** type,
- **Bookmark Animator** type,
- **Bézier Curve Path** type.

When open, the **Camera Animations** editor will always show the information for the current active clip in the Timelines editor. To change the clip shown in the **Camera Animations** editor, select a different clip in the **Timelines editor** :





- Click on the name of a clip in the **camera animations** list,
- Click on the representation of a clip in the **Camera** track,
- Create a new camera animation using the button below the **camera animations** list in the library. This will create a new clip and activate it.

Rename your animation in the text zone at the top of the editor. It is recommended that you give each animation a different name.

Kam File Type

If you have selected **Kam File** as your camera path, the scene will be animated according to an existing animation path, which might have been created, for example, by the export of a **bookmark animation** [107] as a .kam file. The **Kam Files** options are displayed in the **Camera Animations** editor.

In the box **File** you have access to the tools to:

Icon	Function
	Import Kam File
	Update Kam File
	Export Kam Animation
	Delete Kam Animation

In the **Parameters** zone, the **Filename** and the number of **Frames** are displayed for your information. In order to convert from a frame-based kam file to a real-time animation, you must provide the **Frame rate** here.

You can indicate whether the Fov, or Field of view, is expressed as a vertical or a horizontal value. You can also opt to **Ignore Fov** value supplied by the .kam file.

Bookmark Animator Type





The **Bookmark Animator** type allows you to define a camera path passing by one or more animation bookmarks that you set up in the animator. You establish the order of the bookmarks, the time spent at each point, and the type of animation used to move from one point to another. The corresponding options are displayed in the **Camera Animations** editor.







The **Time Parameters** zone concerns the global duration of the animation. Define the pauses between bookmarks and the duration of each bookmark. The **Total Time** of the animation is calculated based on this information.

Tick the **Close Path** checkbox to animate the transition between the last and the first bookmarks when the animation playback is looped. This option is checked by default.

The **Bookmark Sequence** zone summarizes the animation bookmarks according to their order in your animation list. It also provides the information concerning each bookmark as a step in the animation.

This zone offers multiple buttons to modify the list of bookmarks:

Icon	Function	Description
	New Animation Bookmark	Adds the current viewport's view of the product to your list as a new animation bookmark.
	Update Animation Bookmark	Replaces the selected bookmark with the current view of the product.
	Duplicate Animation Bookmark	Creates a bookmark identical to the selected bookmark and adds it to the end of the list.
	Insert Active Camera Set	Inserts the Cameras from the last active group in the Cameras editor. The position and orientation of the cameras are imported as bookmarks and placed below the current selected bookmark .

Icon	Function	Description
	Import Bookmark Animation	Opens and loads bookmark animations previously saved in .kba or .kam formats.
	Export Bookmark Animation	Saves the current bookmark animation in KBA or KAM format.
	Move Bookmark Up in List	Moves the selected bookmark to position it higher in the list.
	Move Bookmark Down in List	Moves the selected bookmark to position it lower in the list.
	Convert to Bézier path	Creates a Bézier path for the camera animation described by the bookmarks in the list.
	Delete Animation Bookmark	Removes the bookmark from the list. Its settings will not be saved.

The **Bookmark** zone concerns the set-up of the selected bookmark:

Parameter	Description
Checkbox	Includes the bookmark in the animation (checked) or excludes it (unchecked).
Label	Allows you to set or modify the name of the bookmark.
Sleep	Defines the duration of the pause of the bookmarked image.
Duration	Defines the duration of the animated transition to the next bookmark.
Smoothness	Sets the fluidity of the camera behavior.
Type	Type of path: <ul style="list-style-type: none"> • Linear: sets a straight path (the rotation parameter fields are grayed out), • Jump: moves from one stage to the next with no transition, • Orbit: sets a circular path (the rotation parameter fields are accessible), • Head: pivots the camera (the rotation parameter fields are accessible), • Spline: smooths the transitions when the camera moves from bookmark to bookmark. • Ease in: Easing is added at the beginning of the animation. • Ease out: Easing is added at the end of the animation. • Ease in and out: Easing is added at the beginning and at the end of the animation.
Orbit/Head	Provides rotation parameters, which are modifiable if you have selected Orbit or Head as the type): <ul style="list-style-type: none"> • During... of step: percentage of the step dedicated to the rotation, • turn...times: number of 360-degree turns to carry out.

Bézier Curve Path Type

For a **Bézier Path** animation, **Camera Animations** defines the behavior of the camera's position and orientation as well as that of the camera target's position.

For the purposes of this editor, the camera is the position of observation, along with properties such as zoom and camera angle. The target, or the point being observed, is the center of the viewport when the scene is viewed using this camera. The center of the current active viewport at the time the clip is created is used as the initial target position for the clip. However, you can set a different initial target in this editor.

The camera's position, its target, or both can be animated by [Bézier curve \[452\]](#) path. Selecting an option for each element allows you to set its behavior for this clip.



TIP

To find the name of a curve, hover over it with your cursor. Its name is displayed in the information bar at the bottom of the screen.



Position path options:

Position	Use	Settings
<i>Follow Bézier path</i>	Choose this option to enable the drop-down menu. This menu lists all of the Bézier curves created in your product. Select the curve you wish to use as the path for the camera's position. The camera will move along the Bézier path at a constant speed.	The button  beside this option reverses the direction of the path.
<i>Follow null</i>	Choose this option to enable the drop-down menu. This menu lists all of the null objects in the product and is available only if you have at least one null. A null constrained by <i>Follow path</i> to a Bézier path and animated by channel animation serves as a moving tripod for the camera. The camera will move with the null object, respecting the easing established by the channel animation. The camera animation and the path constraint animation must start and end at the same time in the timeline. For more information see: <ul style="list-style-type: none"> • Channels (Editor) [154] • Animation Constraints [296] 	

Position	Use	Settings
Stationary	Choose this option in order not to animate the camera's position.	The button  beside this option sets the fixed camera position using the camera position in the active viewport.

Target path options:

Target	Use	Enabling Enhanced Transparency	Settings
Follow Bézier path	Choose this option to enable the drop-down menu. This menu lists all of the Bézier curves created in your product. Select the curve you wish to use as the path for the camera's target		The button  beside this option reverses the direction of the path.
Follow position path	Choose this option to have the target's position be calculated automatically in order to precede the camera along the camera's position path.	Only available if you have selected Follow Bézier path as the Position path.	
Follow null	Choose this option to enable the drop-down menu. This menu lists all of the null objects in your product. Select the object you wish to use as the camera's target.	Only available if you have at least one null. A null constrained by Follow path to a Bézier path and animated by channel animation serves as a moving base for the camera's target. The camera animation and the path constraint animation must start and end at the same time in the timeline.	

Target	Use	Enabling Enhanced Transparency	Settings
Fixed direction	Choose this option to lock the target's position in relation to the camera and prevent the modification of the camera's orientation. As the camera moves along its path, the target moves in exactly the same way.	Only available if you have selected Follow Bézier path as the Position path.	The button  beside this option sets the relative target and camera positions based on the current relationship in the active viewport.
Stationary	Choose this option in order not to animate the target's position.		The button  beside this option modifies the initial target position by replacing the previous initial position with the current center of the active viewport.

In the **Duration** field, provide the clip length in seconds.



NOTE

A camera animation by **Bézier path** provides a linear development of the camera and target positions over time, and takes into account all of the curve as the path.



TIP

The start point along the curve is defined on the Bézier path itself. Right-click on the curve where you would like to place the start point and select  **Place start here.**

Example: Creating a Rotor Animation

The "rotor" camera path with a ping-pong effect simulates the rotation of a product as if it had been placed on a rotating pedestal whose center corresponds to the point at the center of the active viewport. In other words, a rotor animation is a rotation around the Y axis at the coordinates of the ZX plane at the center of the active viewport.

A rotor animation can be easily created using a **bookmark animation camera** path.

1. Open **Timelines** and **create a new camera animation**.
2. In the **Camera Animations** editor, give your animation a meaningful name, such as "**Rotor Animation**".
3. Choose the **bookmark animator camera path [107]** type.
4. Position your product. The point at the center of the viewport will provide the ZX coordinates to use as the central point of the rotating plane.
5. Create a bookmark in the **Camera Animations** editor by using the **New Animation Bookmark** button .
6. In the **Bookmark** zone, provide the following information:
 - **Duration** : Enter the desired duration of the rotation in seconds.
 - **Type**: Choose the value **Orbit**. This will create a rotor movement.
 - **Orbit/Head > During... % of step**: Enter **100** to have the rotor movement occupy the full duration of the bookmark.
 - **Orbit/Head > Turn... times**: Supply the number of times to turn. For a rotor movement, this value is usually between **0** and **1**. **1** corresponds to a full rotation around the center point; **0.5**, for example, corresponds to half of a rotation around this point.

To implement a ping-pong effect:

1. Place your animation clip in the timeline.
2. Place a second instance of the same clip in the timeline, positioned so that it begins exactly when the previous instance ends.
3. Select the second clip by clicking on it.
4. Using the mouse, right-click on your selection to open the context menu and select the option **Reverse playback**.



TIP

To make the transition from one bookmark to the next during a ping-pong effect appear more fluid, increase the **Smoothness** in the **Camera Animations editor**.

Backgrounds (Editor)





Available in: **Matter: Editors > Backgrounds**

Backgrounds  is a floating editor that allows you to create backgrounds and to change the parameters of the active background.

The interface is organized into three zones:

- Operations bar and name of the active background: Displays operations available in the Matter sidebar's background library.
- **Gradient**: Displays the controls and parameters of a color gradient background.
- **ImageMap**: Regrouping of the parameters concerning the superposition pattern.

The following buttons are present in the operations bar:

Icon	Description
	Start point for dragging and dropping the background to assign it to a sensor or to a viewport.
	Enables an eyedropper for selecting the background used in a viewport in order to edit it.
	Assigns the background being edited to the sensor in the active viewport.
	Creates a new background.
	Duplicates the background currently being edited.

In the **Gradient** zone, the gradient type of background can be enabled and the beginning and end colors for the gradient can be defined. You can also.

- Lock the color  to force a solid color to be used as the background,
- Modify the **Orientation** of the gradient.

In the **Map** zone, you can edit the properties for an image type of background:

- The check-box next to the Map image allows use of the texture to be enabled or disabled.
- Drag and drop a texture from the Matter sidebar's texture library. This field accepts video textures. Clicking on the name of the Map in use takes you to the current texture group in the Matter sidebar's texture library.
- Check the **Preserve texture aspect** box to prevent the image scale defined in this editor from being modified when the viewport is resized.
- Provide the **Offset** (position of the texture in the viewport), the **Scale** and the degrees to **Rotate** the background texture.
- Lock the transformation scale  to apply uniform scaling of the texture's vertical and horizontal axes.

You can combine an image with the gradient and configure the image's transformation to shift it using the **Offset** values, repeat it with the **Scale** values, and rotate it.

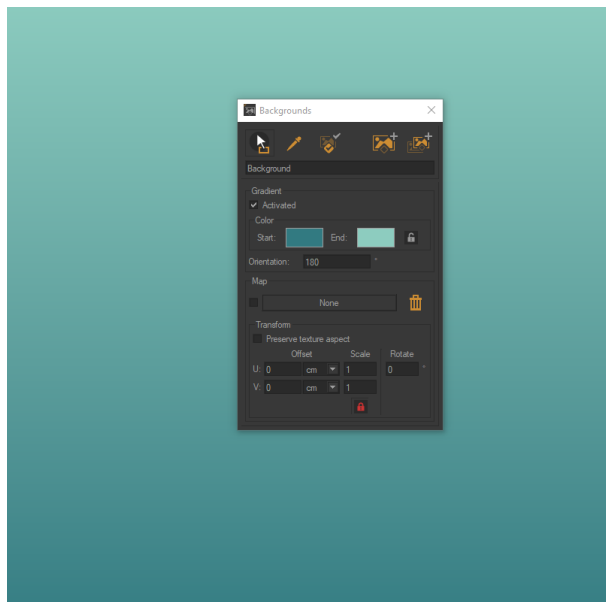
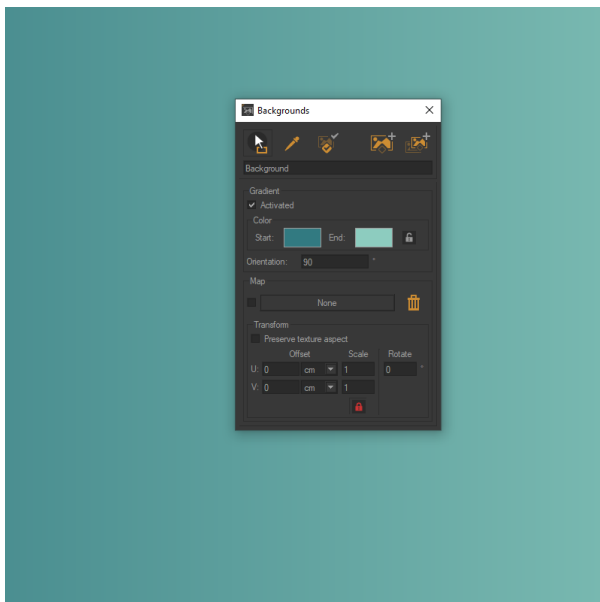
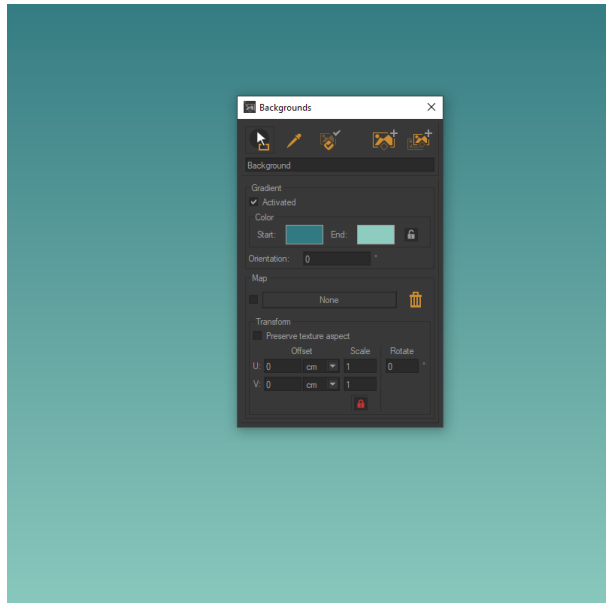
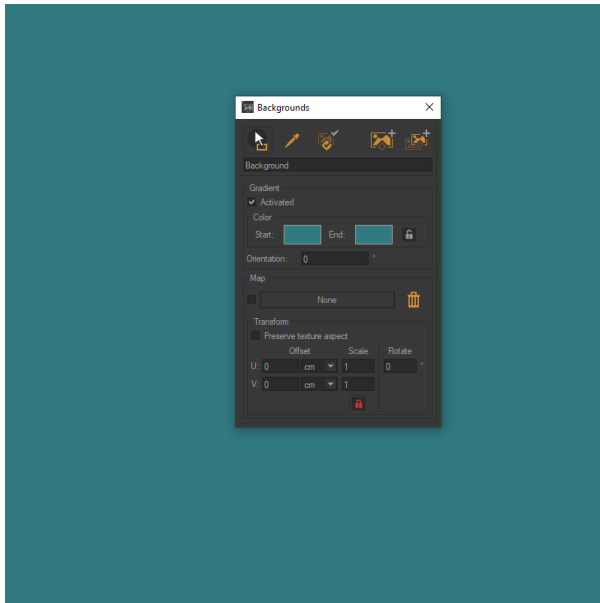

First row: Solid background, gradient background. Second row: Using different values of rotation (left: 90 degrees; right: 180 degrees) to orient the gradient.

Unfolding & Stitch Workshop





NOTICE



All the features described below may not be present in your software edition: Community, Premium, Essential, or Enterprise.

Available in:

Shaper:

- Via the upper toolbar  >  **Display all visible surfaces** or  **Display selected surfaces**
- Via the **Edit unfolding/stitch for the selected surfaces** menu for a multiple selection.
- Right click on a surface **Edit unfolding/stitch for** for a surface under the cursor or **Edit unfolding/stitch for the selected surfaces** for a multiple selection.

Matter:

- Via the lower toolbar  >  **Display all visible surfaces**
- Via the menu **Editors** > **Edit unfolding/stitch for the selected surfaces** >  **Display selected surfaces**
- Via a right click on a surface **Edit unfolding/stitch for**

The **Unfolding** tab of the **Unfolding/stitch Workshop** is a tool that allows you to:

- set the UV mapping of complex surfaces by unfolding,
- cut the UV mapping of complex surfaces that need to be cut to flatten.

The **Stitches** tab of the **Unfolding/stitch Workshop** is a tool that allows you to create and edit geometry bands that support seams.



NOTE

The Unfolding/stitch Workshop is now non-modal, which means you can use it in **Matter** as well. Any modification of a surface will be directly applied in **Shaper** and **Matter**. Unless the checkbox **Disable automatic update in Shaper and Matter** is checked, in which case the

update is no longer done automatically. In this case, click on this icon  to manually update the unfolding.

The unfolding workshop interface consists of four zones:

- The main toolbar,
- The 2D **UV zone**,
- The 3D **Geometry** zone,
- The edition zone that contains the following tabs: **Unfolding** and **Stitches**.

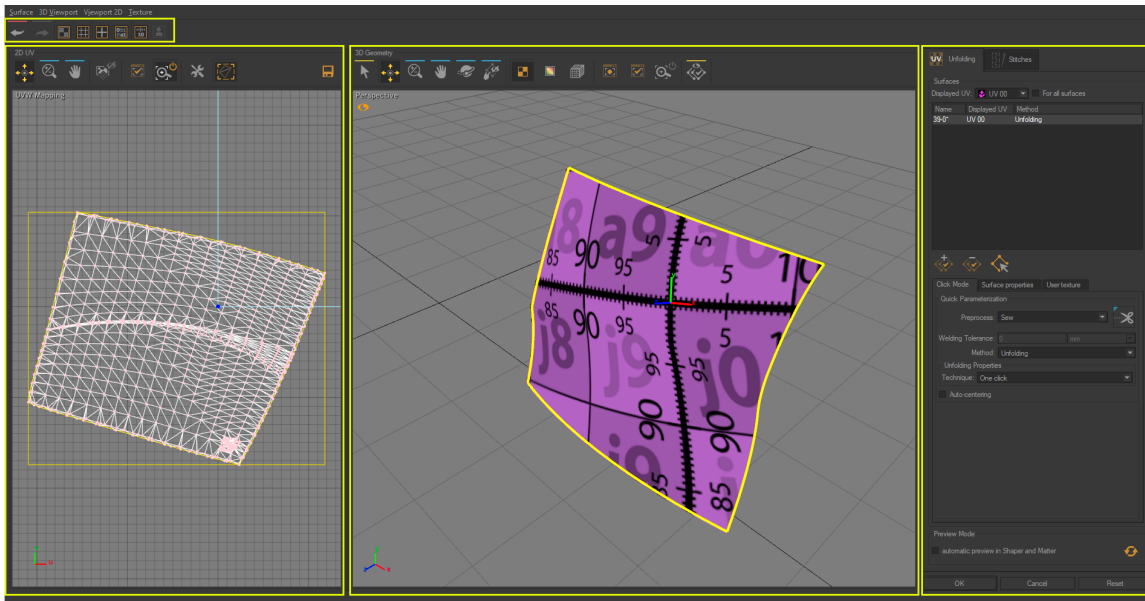



Main Toolbar

The main toolbar contains two buttons to display the selected or visible surfaces, as well as six background texture options to make it visually easier to understand the unfold procedure that has taken place.



NOTICE

 : To cancel the last unfolding action. Keyboard shortcut **Ctrl+Z**

 : To restore the last unfolding action. Keyboard shortcut **Ctrl+Y**



NOTE

Please note that **all actions carried out in the unfolding workshop** are considered as a **single action** to undo or redo in *Shaper*.

<https://www.youtube.com/embed/qDibFs9ScK8>



: The texture options change the background and surface texture for the selected unfolded surfaces.

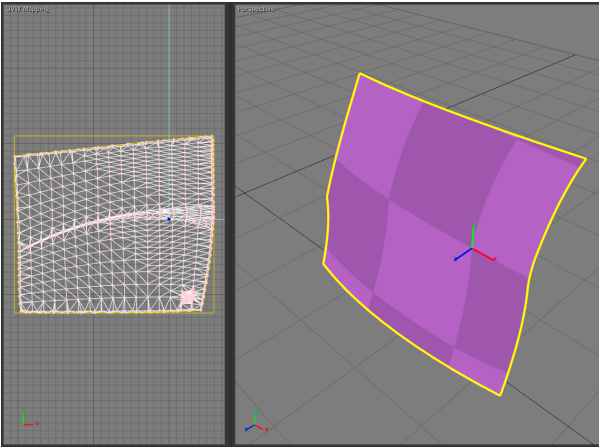

 : Checker

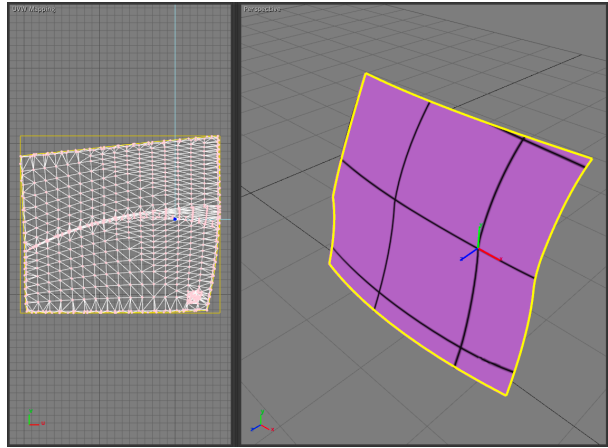

 : Grid

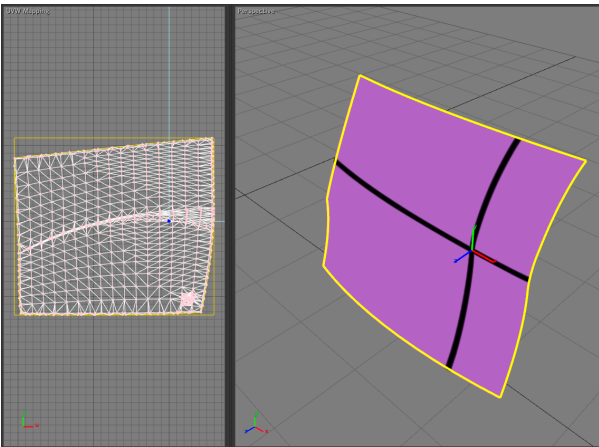

 : Frame

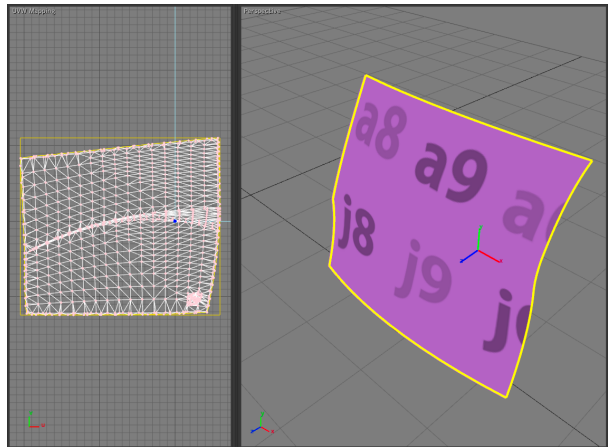

 : Letters

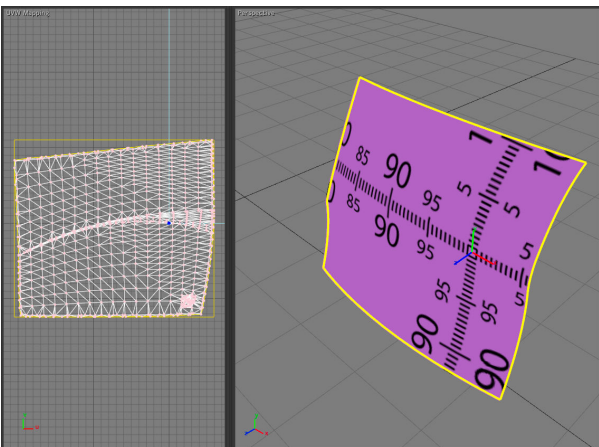

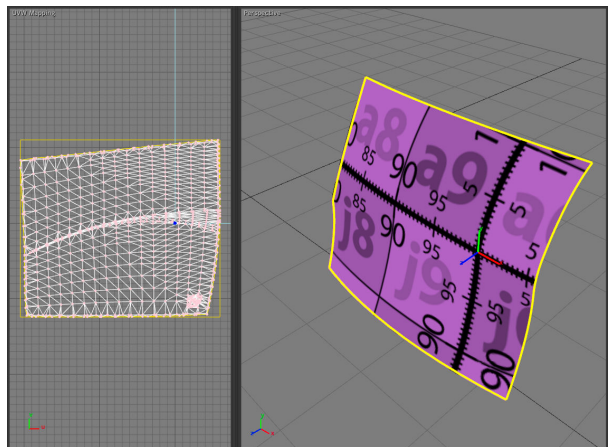

 : Rules

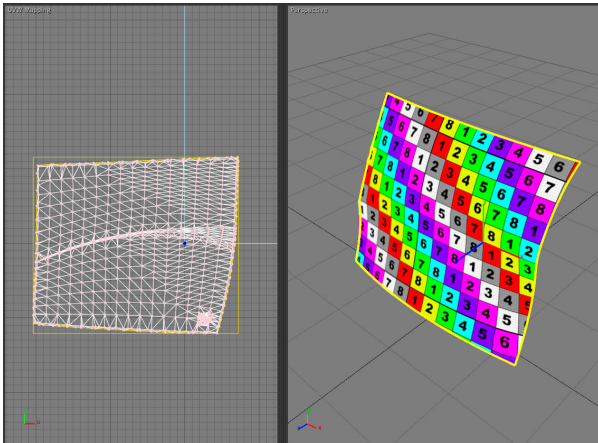

 +  +  +  + 

: The **User-defined texture** toggle is for enabling/disabling the background texture of your choice.





: User-Defined





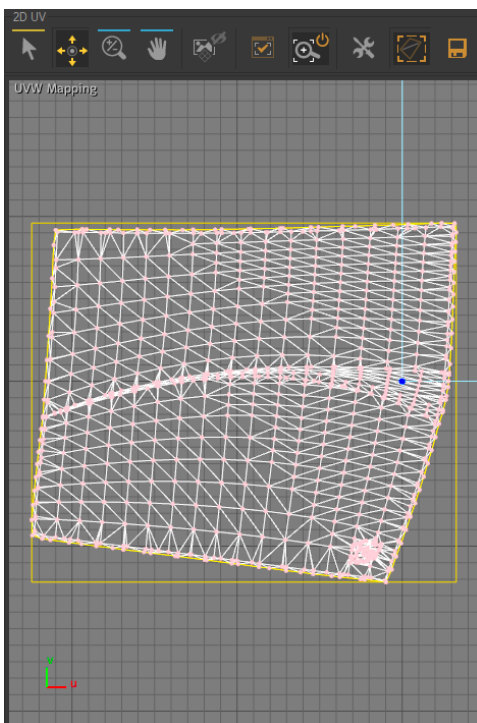



The procedure for loading a texture file of your choice is explained below in the [User Texture \[127\]](#) subsection of the **Surfaces** section.

2D UV Zone

In the unfolding workshop interface, the UV-mappings obtained are displayed in the **2D UV** zone. The user can now adjust the unfolding of the surface directly from the 2D view by defining additional constraints, or by modifying or releasing existing constraints. The position of the texture on the surface is updated simultaneously, which allows the user to view the effects of the adjustments.



Icon	Operation	Description
	2D Translation Gizmo	Adjust manually the unfolding in relation to the UV.

Icon	Operation	Description
	Pan	Pan in the 2D view.
	Zoom	Zoom in the 2D view.
	Edit control points	Adjust manually the unfolding in relation to the UV.
	Background	Enable/disable the display of the background textures (see the Main Toolbar [116] subsection).
	Zoom Selection to Fit	Reframe the 2D view and center it on the selected unfolded surface.
	Auto Zoom Selection to Fit	Enable/disable the automatic reframing of the view on the unfolded surfaces when they are selected.
	Edit parametrization margin	Open an editor for defining margins around the unfolding so that it will be easier to use after export.
	Show bounding-box	Enable/disable the display of the previously defined margins.
	Export parameterization	Open an editor for configuring and then exporting the 2D image of the unfold that has taken place. In this way you can use your surface-unfolding work with graphic creation tools to edit textures that are perfectly suited to the programming of your surfaces.

Defining a Constraint

The user can convert the markers previously set on the surface in the 3D view into constraints either by simply left-clicking in the UVW Mapping window or by using the **Convert Markers to Constraints** option accessed by right-clicking in the 2D view.

- For a surface unfolded using the **One-click** option in the **Hit Mode** tab of the **Surfaces** panel, the three vertices of the triangle the marker is set on will be converted into constraints.
- For a surface unfolded with the **Multi-constraints** option, the vertices of all triangles containing a marker will be transformed into constraints.
- When a surface was unfolded with the **Follow Boundary** option, all vertices on the corresponding boundary are converted into constraints.

These constraints are represented by green dots in the UVW mapping. Any point thus highlighted represents a constraint.

Any point in the UVW mapping may be moved to create a deformation using the **Select and Translate** tool from the **2D UV** toolbar. The parameterization is updated in real time. Moving a point with no constraint assigned to it defines a new constraint. The point is then highlighted.

Modifying a Constraint

To modify a constraint, the **Select and translate** tool must be activated. The highlighted point may be set to another position by dragging it, thus modifying the constraint.

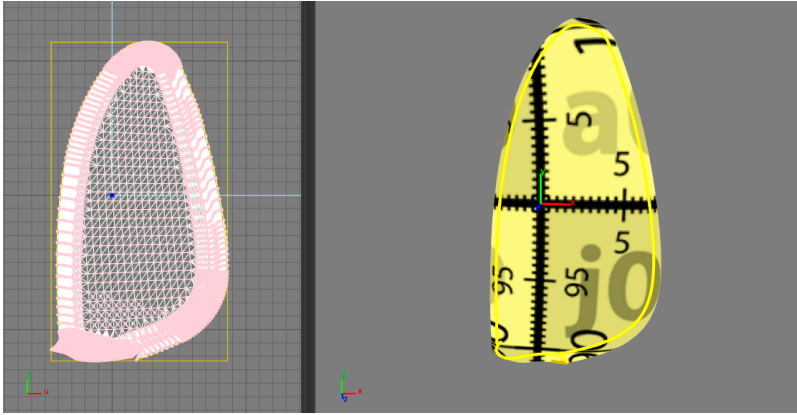

UV mapping of a surface unfolded using the one-click method and corresponding 3D view.

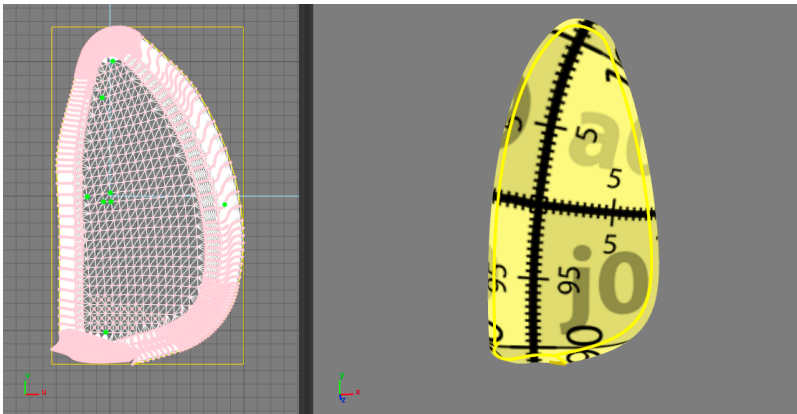

UV mapping of the surface after an additional constraint was added and corresponding 3D view.

Releasing a Constraint

To release the constraint set on a point, the option **Release Constraint on Selected Point** must be chosen. This option is accessible by right-clicking on the corresponding highlighted point.

All the constraints set on the UV mapping can be released at the same time by using the option **Delete all markers** accessible by right-clicking in the **UVW** mapping view.



TIP

Right-clicking inside the **UVW** mapping window gives access to the two options **Delete All Markers** and **Convert Markers to Constraints**. The third option, **Release Constraint on Selected Point**, is only displayed by right-clicking on a highlighted point.





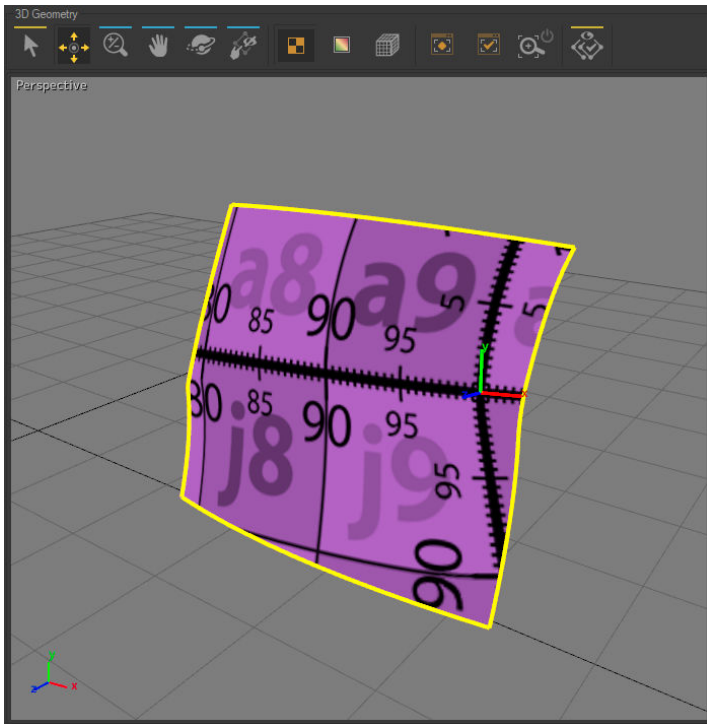

3D Geometry Zone

The **3D Geometry** zone contains an interactive 3D view in which the surfaces to be unfolded and several tools for unfolding and manipulating the surfaces are displayed.



The **3D Geometry** toolbar changes its look depending on the following operation modes: **Unfolding** or **Stitch**.

Icon	Operation	Unfolding	Sew	Description
	Selection	✓		Select surfaces.
	Move Marker	✓		Select and move a marker on the unfolded surface.
	Zoom	✓	✓	Zoom in the 3D view.
	Pan	✓	✓	Move around in the 3D view.
	Orbit	✓	✓	Control the rotation of the 3D view in order to observe the surfaces from different points of view.
	Set Render to Texture	✓		View the background textures of an unfolded surface.
	Set Render to Deformation	✓		View a highlighted distribution of the physical forces associated with the deformation of the unfolded surfaces.
	Show Wireframe	✓	✓	Enable/disable the display of the surfaces' wireframe.
	Zoom to Fit	✓	✓	Reframe and center the 3D view on of the surfaces in the unfolding workshop.

Icon	Operation	Unfolding	Sew	Description
	Zoom Selection to Fit	✓	✓	Reframe and center the 3D view on a selection.
	Auto Zoom to Selection to Fit	✓	✓	Enable/disable the automatic reframing of the view on the unfolded surfaces when they are selected.
	3D Selection Only	✓	✓	Limits the display of the 3D view to the surface being unfolded. To return to a view of all selected surfaces, click on this button again.
	Show/Hide seam curve point for selected seam		✓	Show the seam curve points.
				 NOTE By default, the seam curve points are displayed.
	Show/Hide seam mesh		✓	Show the mesh of the seam.
				 NOTE By default, the geometry band mesh is displayed.

In the **Unfolding** tab, a right click on 3D Geometry Zone you can:

- **Delete a marker,**
- **Insert New Marker After,**
- **Delete All Markers,**
- **Convert Markers to Constraints.**

Edition zone

Unfolding tab



The **Surfaces** box contains an area for exploring the surfaces involved and three tabs for configuring the methods for unfolding and viewing them.

The area for exploring the surfaces lets you select the surfaces by their name and view the unfolding method used. (The selected surface is highlighted).

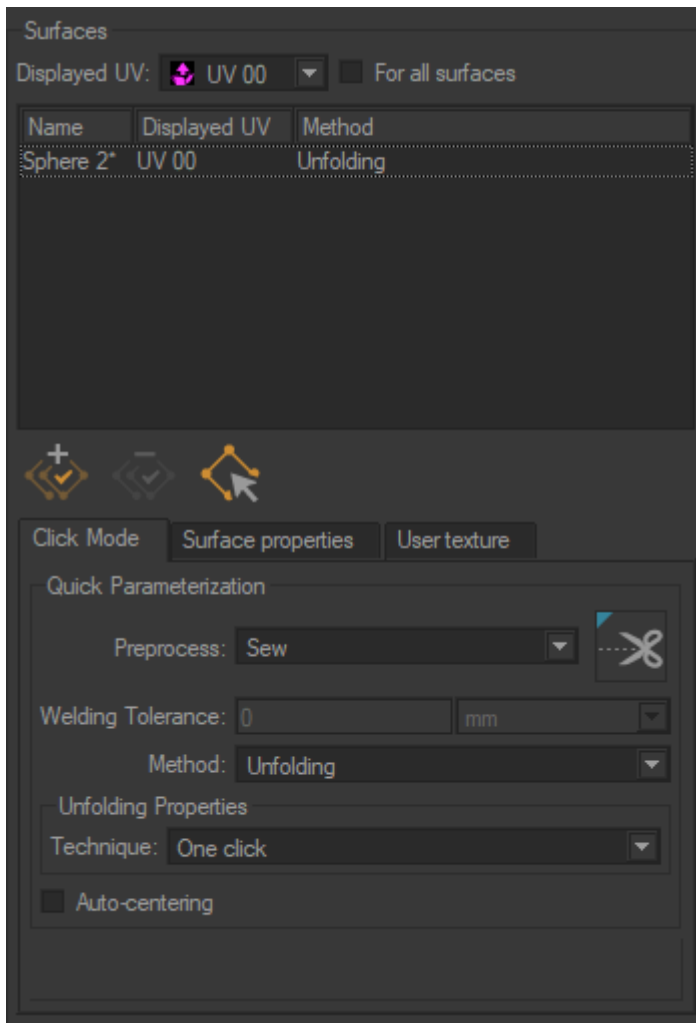
Each surface can combine up to 32 separate unfolding sets. The **Displayed UV** channel allows you to choose the set of UV targeted by the unfolding.



NOTICE

Icon	Operation	Description
	Add selected surfaces	Adds the selected Shaper surface(s) to the Unfolding Workshop.
	Delete selected surface	Removes the selected surface from the Surface Explorer.
	Select surfaces in Shaper	Selects in Shaper the open surfaces in the Unfolding Workshop



NOTE

Please note that the **Undo** and **Redo** functions do not apply to surface addition and deletion actions in the Unfolding Workshop.

This zone is followed by several tabs which give access to the workshop settings.

Once you have completed your unfoldings, click the button **OK** to validate your unfoldings, **Cancel** to cancel them, or **Reset** to cancel and start your unfolding from the beginning.

**NOTE**

Please note that **all actions carried out in the unfolding workshop** are considered as a **single action** to undo or redo in *Shaper*.

Click Mode

The **Click Mode** tab provides access to the fast unfold general options.

Preprocess provides access to three types of preparation: **None**, **Sew** and **Weld & Sew**.

Preparation	Description
None	Uses the current topology of the surface.
Sew	Carries out a sewing operation on the edges.
Weld & Sew	Carries out a sewing and joining operation on the edges.



Find the description of the **Surface Cutting Workshop** in a dedicated chapter. See the [Surface Cutting Workshop \[130\]](#) for more information on how it works.

Welding Tolerance assigns a numerical value to the tolerance of the CV's when the **Weld & Sew** mode of preprocess is selected.

Method provides access to three types of unfolding methods: **None**, **Copy** and **Unfolding**.

Method	Description
None	Remove and cancel the previous unfolding work.
Copy	Is used to retrieve an existing unfolding method. In Copy mode, the unfolding workshop offers the choice of currently-defined UV sets. A drop-down menu allows you to browse the UV sets and select the most suitable set for unfolding the selected surfaces.
Unfolding	Create an unfolding of the surface using the 3D view. Unfolding Properties: Technique provides access to three different unfolding techniques: One click , Multi constraints and Follow boundary . These techniques are described below.

**TIP**

The **Quick Assignment** mode must be enabled in order to execute an unfold operation and view its representation (see "[3D Geometry Zone \[120\]](#)" above).

One click: is for creating a new unfold with just one click on the surface to be unfolded. The origin of the unfold is on the surface at the precise location where the click has been made. With this technique, the orientation of the texture is always positioned so that the y axis of the texture is parallel to the vertical edges of the 3D view.

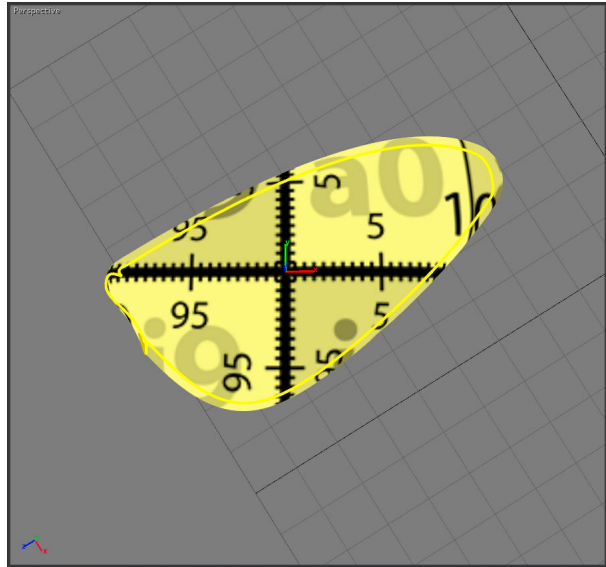
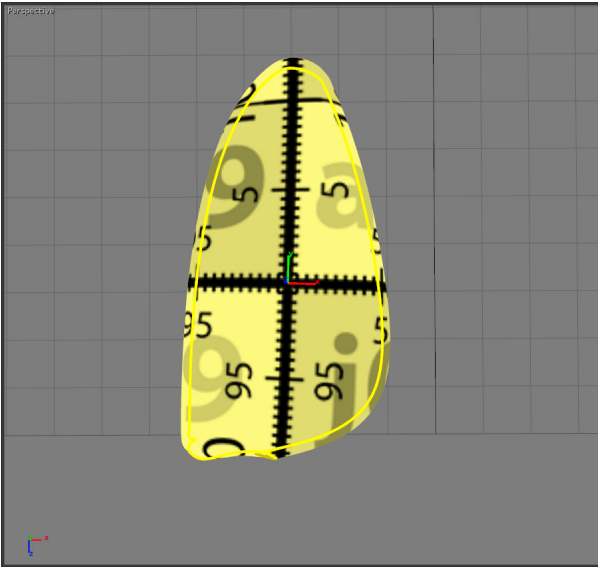

Multi constraints: is for assigning several markers to the unfold so that it precisely follows the form of the surface.

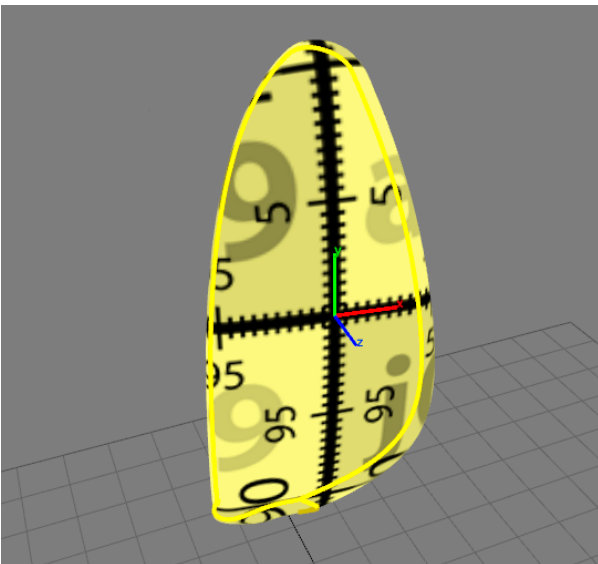

One click method.

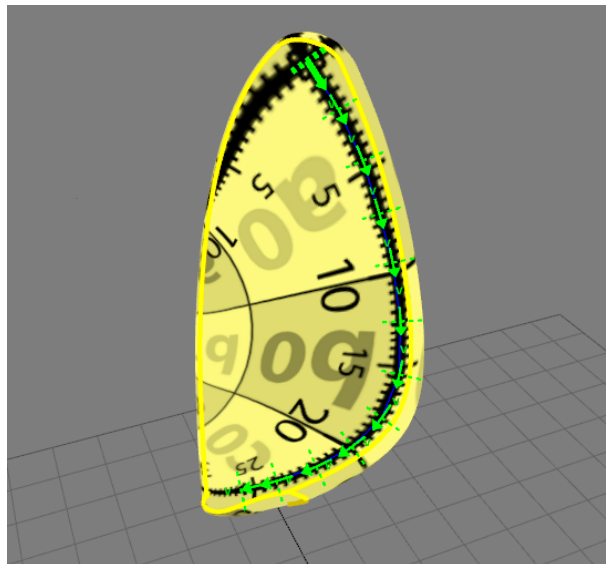

Multi-constraints method.



TIP

It is possible to change the position of the markers at any time using the **Move marker** tool (see "[3D Geometry Zone \[120\]](#)" above).

Follow boundary: is for constraining the unfold to a specific edge of a surface. Two markers are necessary for this unfolding technique.

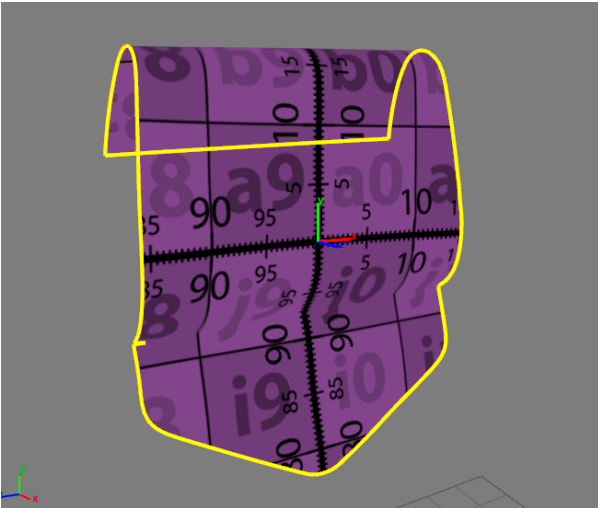

One click method.

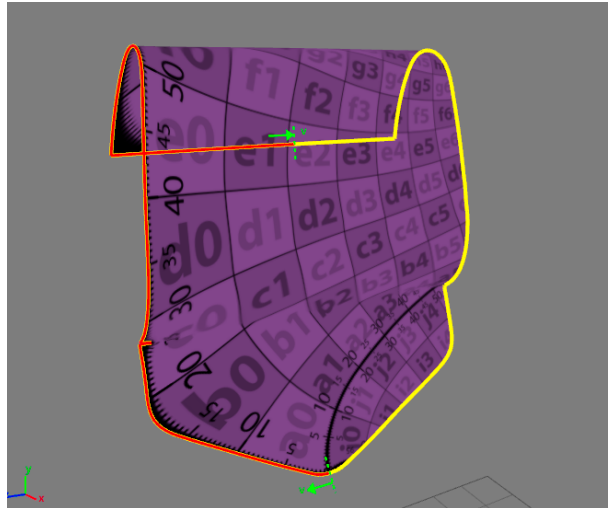

Follow boundary method.

The **Auto centered** option is for positioning the origin of the texture in the center of the surface, regardless of where the click has been performed.

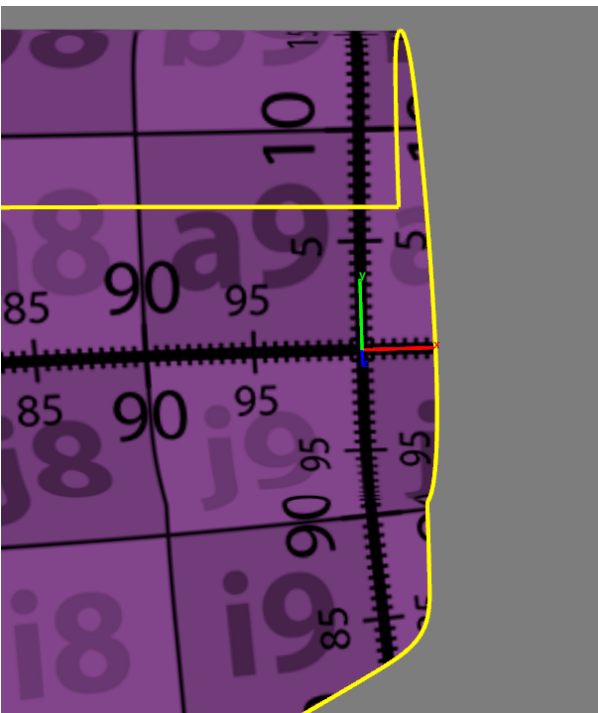

Auto-centered disabled.

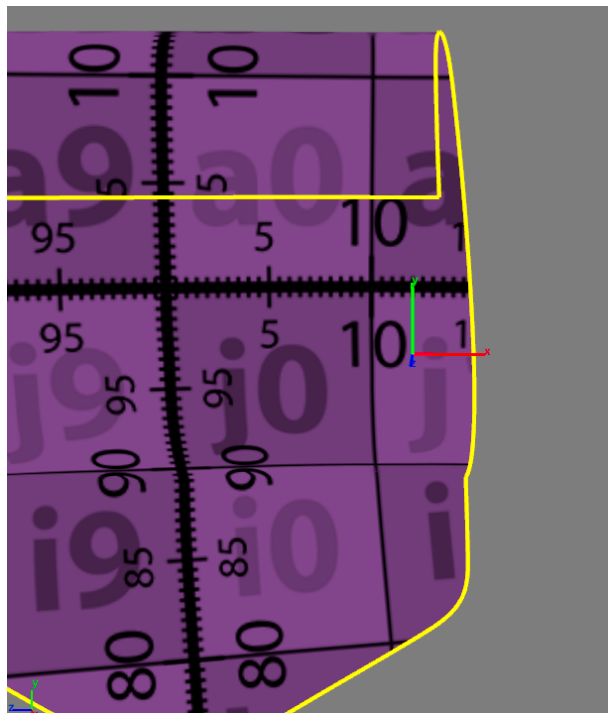

Auto-center enabled.

Surface Properties





The **Surface Properties** tab provides access to the unfold options depending on the selected unfolded surface.



The **Reset** button is for re-establishing the initial unfold assigned to the surface.

The **Parametrization** frame provides the same unfolding options as in the **Hit mode** tab (see the **Hit Mode [124]** Tab section).

When the unfolding methods **Multi constraints** or **Follow boundary** are chosen, the placement of markers that define the constraints are handled using the following buttons:

Icon	Function	Description
	Place marker	Place a new marker at the clicked location on the selected surface
	Delete all markers	Delete the markers created with the Multi constraints unfolding technique.
	Swap boundary markers	Reverse the direction of the markers created with the Follow boundary unfolding technique.
	Set	Confirm the adjustments made on the selected surface.

The UV **Transformation** frame is for positioning the texture using numerical values.

The **Automatic centering** option is for positioning the origin of the texture in the center of the surface.

User Texture

The **User Texture** tab provides access to the properties of a user texture.



: The **Open texture** button is for loading a texture from your documents.



: The **Reload texture** button is for updating the loaded image.

The **Dimensions** frame is for assigning metric values to the texture dimensions.



: The **Reset texture dimensions** button is for canceling the values assigned to the texture dimensions and for returning to the initial values.

The **Preview** frame is for viewing the image loaded for the texture.

Stitches tab

The stitch workshop creates geometry bands that support sewing materials to create realistic seams.





NOTE

Surfaces must be unfolded first if you want to use the stitch workshop. The following icon  helps you to identify unfolded surfaces. The **UV** column lists the channel on which one or more seams were made. The **Seams** column gives the number of seams the surface has.

Like the **Unfolding** tab, you can select the UV channel (**Displayed UV**) in which you want to stitch a seam. The parameter **For all surfaces** allows changing the displayed UV channel for all surfaces.

Two stitching method are available:

-  **Free Draw Seam** freely stitches the seam on the surface without constraints.
-  **Follow Surface Boundary** constraints the stitch to the surface boundaries.

You can adjust the **Width** of the geometry band which will serve as a support for the seam and set the **Offset from surface** to move the seam just over the surface.

You can also set the **Offset from boundary**. This parameter is only available with the **Follow Surface Boundary** stitching method.

The **Precision in length** parameter increases the number of points between the markers in the geometry strip. Conversely, the lower the number of stitches, the more the seam will be straight. A straight seam, for example, requires very few stitches (simple mesh), while a sinuous seam that hugs curved surfaces generally requires a high number of stitches (complex mesh).

The **Precision in width** parameter increases the number of points between the markers in the geometry strip. The higher the number of points, the more detailed the geometry strip will be. Conversely, the lower the number of stitches, the more the seam will be straight. This parameter is very useful for making concave or convex a strip of geometry that simulates a seam at the border of a material (leather, fabric, etc ...).

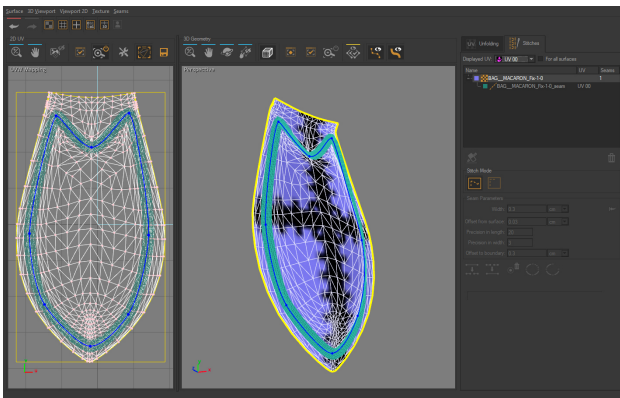

Example a geometry strip with a width of 0.3 cm with the value of 20 for the precision in length and a value of 3 for the precision in width.









TIP

It is possible to use the **2D UV** and **3D Geometry** zones whatever the stitching method used to create the seams. The drawn of the seam points is done in the UV Mapping (2D view). The drawn is automatically transferred to the 3D view. If some artifacts appear in the 3D view, check the place points and move them in the 2D view accordingly.

Free Draw Seam

Add as many points as necessary to create your seam. It can be open or closed. If you need to make a closed seam, right-click on the last stitch of the seam and select **Close Selected Seam**.

By a right-click you can change the shape of your seam using the following options:

Icon	Function
	Finish editing selected seam
	Delete selected seam point
	Delete selected seam
	Open selected seam
	Close selected seam
	Join selected seams for two open seams.
	Split selected seams into two separate seams. To do so, select two points of the seam to identify the segment to be split.



TIP

For more realism, you can also add curves to the seam with the following keyboard shortcuts:

Alt + click adds a tangent to the selected point.

Ctrl + click on a tangent endpoint breaks the angle of the tangent.

Ctrl + **Shift** + click you can change the length of one side of the tangent while keeping the same axis for both sides. The tangents of the geometry band are handled in the same way as the [Bézier curves \[455\]](#).

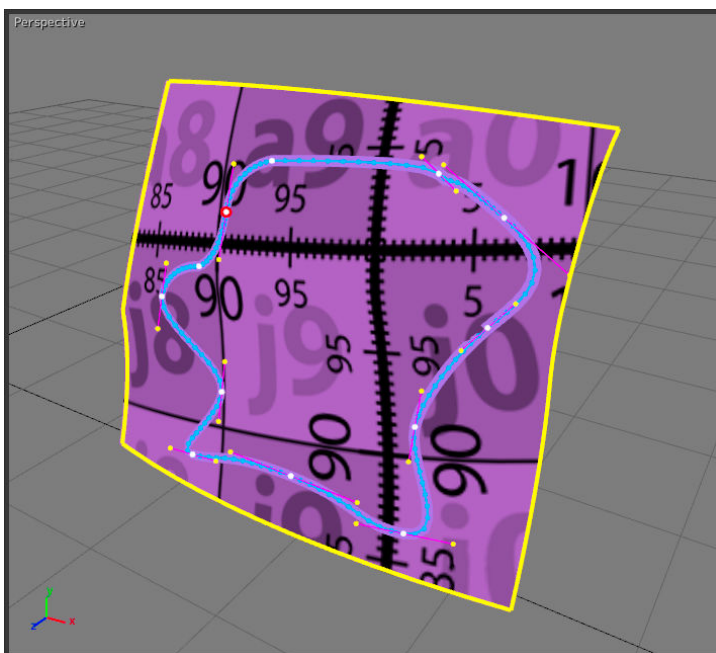

Free draw seam with a width of 0.6 cm and a precision of 10.

Follow the surface boundary

Two markers are needed to create a seam: one at the start of the border and the other at the end. The seam can be opened or closed.

For a closed seam to be made correctly, the start marker and the end marker must be as close as possible or even joined (see. **Close selected seam**).

When flying over the surface, the nearest point on the border is displayed with the green arrow. It indicates the direction that the seam will follow. The blue arrow indicates the offset of the geometry strip from the border.



NOTE

You can manually move a curve control point at any time. You must return to free mode to do so.



WARNING

Warning: manually modified points will be ignored when modifying the **Offset from boundary**.

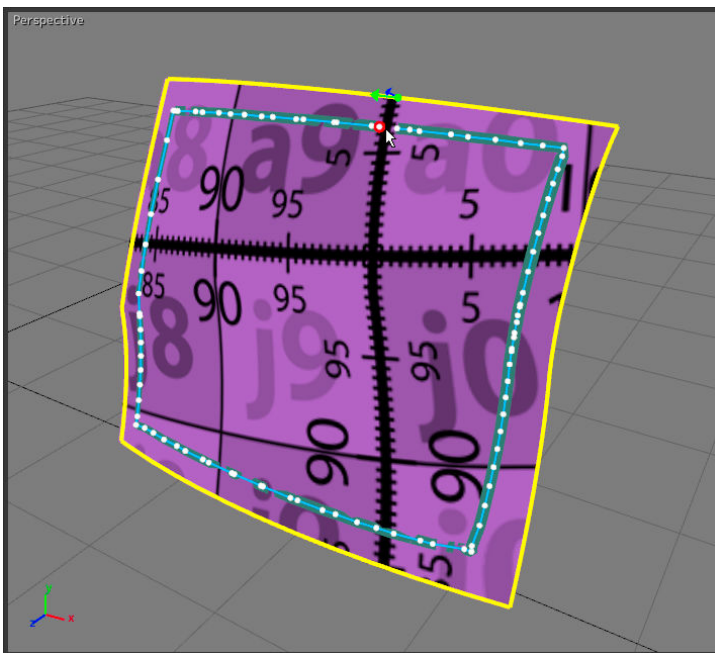

Seam following the surface boundary with a band width of 0.6 cm and an offset from the boundary of 2 cm.

Surface Cutting Workshop

Available in: **Shaper: Surface > Unfolding > Edit unfolding/stitch for selected surfaces > Cutting Workshop**



The Surface Cutting Workshop is a tool available from the **Unfolding/Stitch Workshop**.

The **Unfolding Workshop** enables users to define the UV mapping of complex surfaces. However, for some surfaces, the UV mapping obtained is not always relevant. This is especially true for surfaces that can't be unfolded onto a plane without being cut in places. In such cases, the surface cutting workshop can be used to manually work out a cutting line that will ensure a quality UV mapping. Cutting paths are defined using control points that are positioned manually.

Surface Cutting Workshop Interface

The surface cutting workshop has a dedicated interface that can be accessed from the standard unfolding workshop once a surface has been selected.

Open the surface cutting workshop by clicking on the  icon in the panel on the right. The surface cutting workshop consists of four zones:

- Validation commands toolbar.
- 3D view.
- 3D geometry toolbar.
- **Cut Properties Panel.**

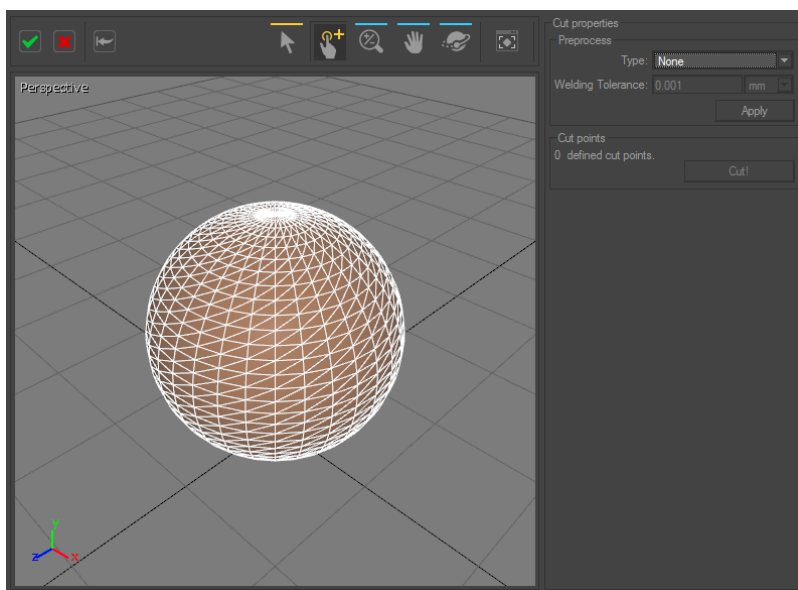

Surface Cutting Workshop interface.

Validation Commands Toolbar



The validation commands toolbar in the top left corner of the surface cutting workshop interface.

The validation toolbar has three options:

- The green checkmark validates the defined cutting path and returns to the unfolding workshop.
- The red cross discards the cutting path and returns to the unfolding workshop.
- The red cross discards the cutting path and returns to the unfolding workshop.



3D Geometry Toolbar



3D geometry toolbar above the 3D view in the surface cutting workshop interface.

The 3D geometry toolbar gives access to tools for managing control points and observing surfaces. The four operating modes for navigating in the 3D view are **Zoom**, **Pan**, **Orbit**, and **Zoom by extent**.

The two tools for managing control points are:

- **Select and Move** tool  for selecting an existing control point and moving it to another position.
- **Quick Assignment**  mode for inserting a new control point.

3D View

This window is an interactive view in which the surfaces to unfold are displayed. It possesses the same functions as all other 3D views in Patchwork 3D.

In this 3D view, the control points are marked in green and the delimited cutting path is displayed in red.

Cut Properties Panel

The **Cut Properties** panel is divided into two boxes, the **Preprocess** box and the **Cut Points** box.

The **Preprocess** box provides access to three modes for preparing surfaces before defining a cutting path: **None**, **Sew**, **Weld and Sew**. The **Cut Points** box allows the user to keep track of the number of control points defined. The **Cut!** button performs a defined cut based upon control points.

Defining a Cutting Path

Preprocessing Boundaries

Depending on the surface topology, the user may wish to prepare before defining a cutting line. The preparation tools available in the **Preprocess** box of the **Cut Properties** panel are **Sew** and **Weld and Sew**. They have the same effects as the preprocess options in the Unfolding workshop.

Defining Control Points

Control points are set using the **Quick Assignment** mode in the 3D geometry toolbar. They may be placed on any triangle vertex. Control points define cutting path segments. Users need to set at least two control points and may set more.

To set a control point, users click on the matching vertex.

Control points are displayed in green. The cutting path segment defined by two control points is the shortest path between them. It is displayed in red.



NOTE

If a control point is behind the surface from the user's standpoint, the green dot will not be visible.

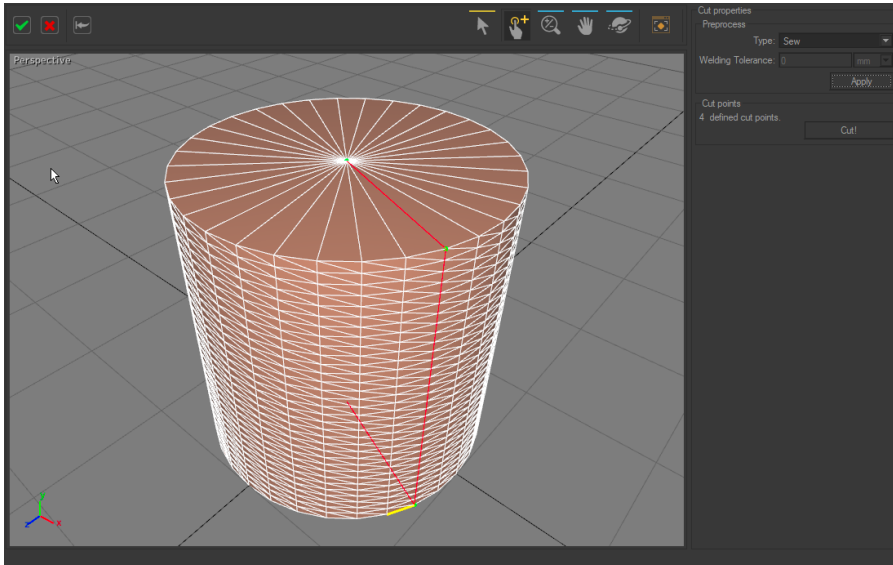

A cutting path defined by four control points: the cutting path is displayed in red and the control points in green.

Modifying Existing Control Points

The **Select** and Move tool is for dragging any of the points belonging to the red line, control points included, and assigning them to another triangle vertex.

Right-clicking on a control point opens a box containing three options. The user may then.

- **Delete** current control point.
- Continue to insert markers using the **Insert New Marker After** option. When this option is activated, the next triangle vertex selected becomes a control point.
- **Delete All Markers.**

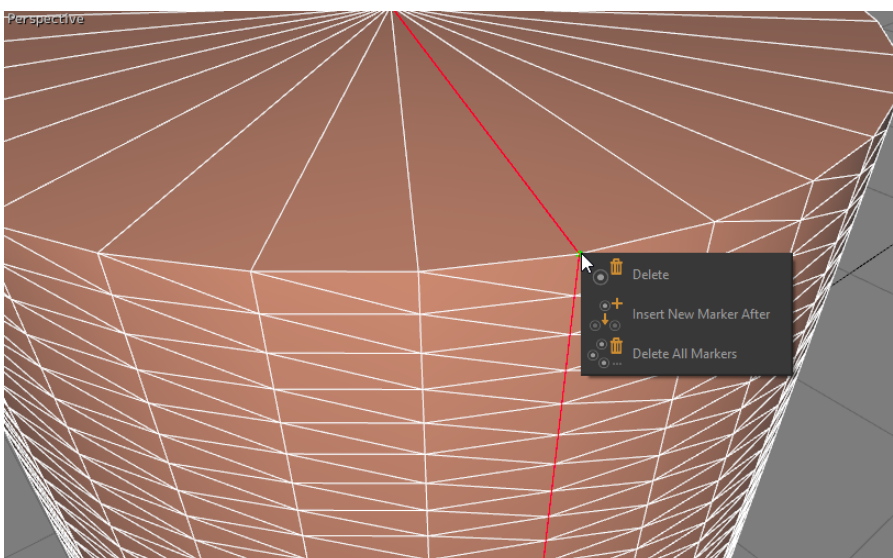

The three options available when right-clicking on a marker.

Applying the Cutting Path

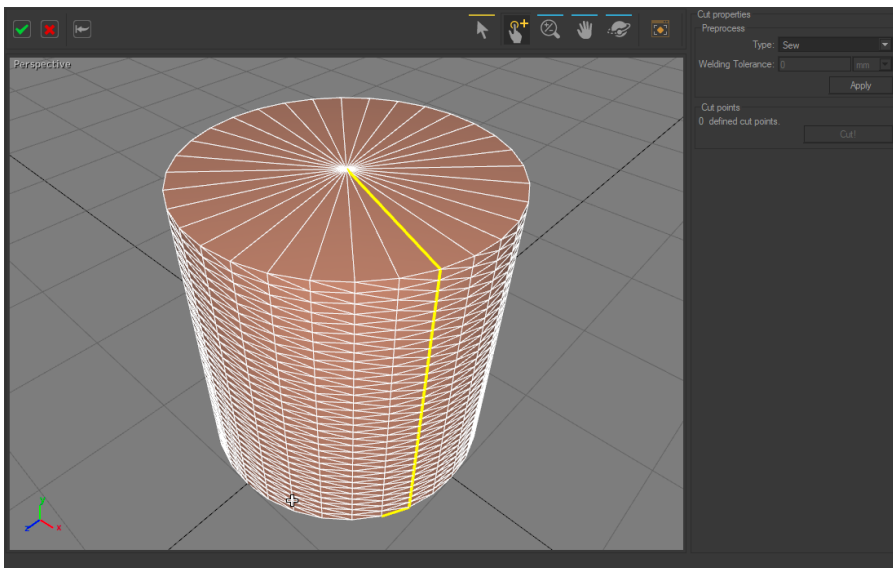

The final cutting path is displayed in yellow. No markers exist any longer.

Once the cut path is defined, cutting is performed by pressing the **Cut!** button. It is displayed in yellow afterward. Users may define additional cutting paths if needed.

In order to unfold a surface, users validate the cut from the validation commands toolbar and return to the unfolding workshop to get the proper UV-mapping of the surface.

In the case of a sphere, the surface cannot be unfolded onto a plane without being cut in places: use of the surface cutting workshop is recommended.

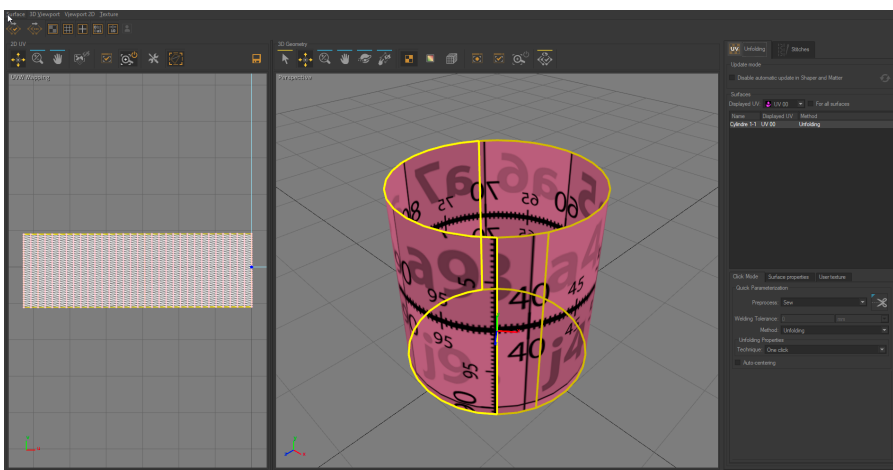

UV-mapping obtained when defining a cutting path in the surface cutting workshop.

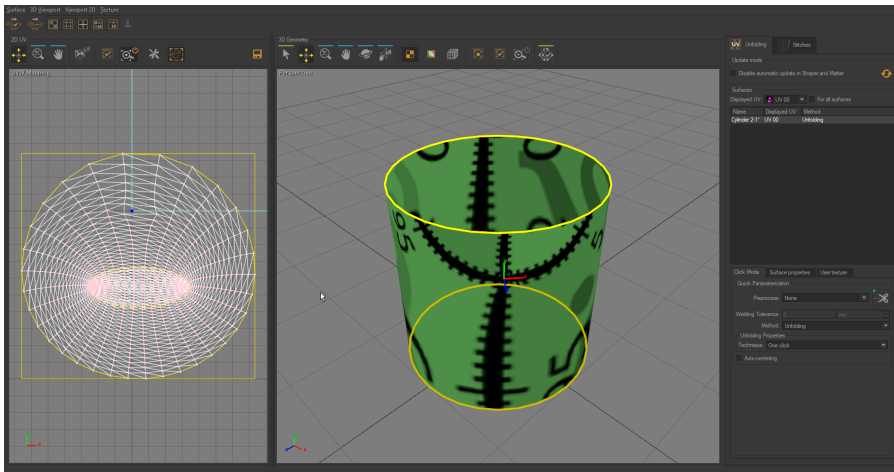







UV-mapping obtained without using the surface cutting workshop.

Timelines (Editor)

Available in: **Matter: Editors > Timelines**

Timelines  is an editor used to develop animation sequences, called "timelines." From this editor, you can create, duplicate, rename, and delete timelines. You can also add, remove, and modify elements in the different animation tracks of each timeline. When played back, the animated result will be displayed in the current active viewport in the main interface of Patchwork 3D.

The **Timelines** editor is divided into two sections: the timeline editing area to the left, and the libraries to the right. The **Timeline** box is the editing area. It contains the playback and time controls, as well as the animation tracks and their content. The libraries are organized into tabs for each type of item:

Tab	Type of animatable element
	Timelines [138]
	Products [139]
	Camera Animations [139]
	Configuration Keys [140]
	Channel Animations [141]
	Textures [142]

Use the arrows in the upper right corner of the library zone to scroll through the tabs.

Timeline Controls

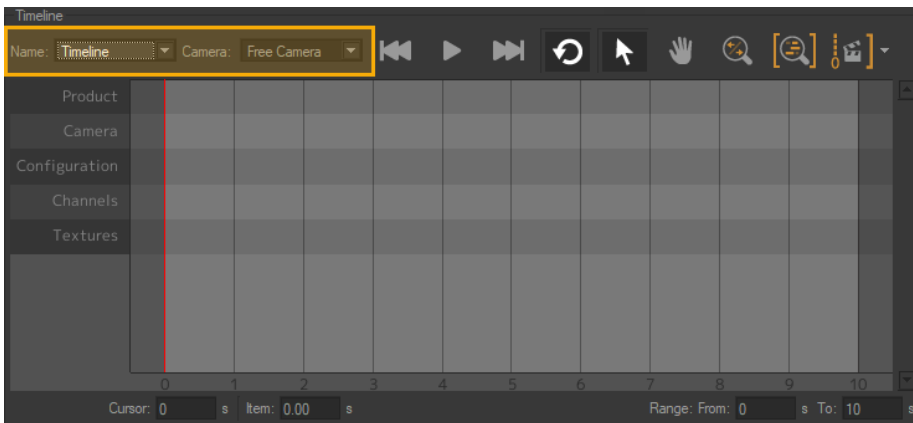

Verify that the timeline shown is the timeline you wish to play back. The current timeline's name is displayed in the **Name** zone. This zone contains a drop-down list that provides direct access to a list of all the existing timelines.



TIP

To modify a timeline's name or to create a new timeline, use the controls available in the **Timeline library tab [138]** to the right.

From the **Camera** drop-down menu, choose the camera to be used to initialize the timeline. If your timeline contains camera clips, these will be applied to the selected camera and will modify its settings. The free camera is selected by default.





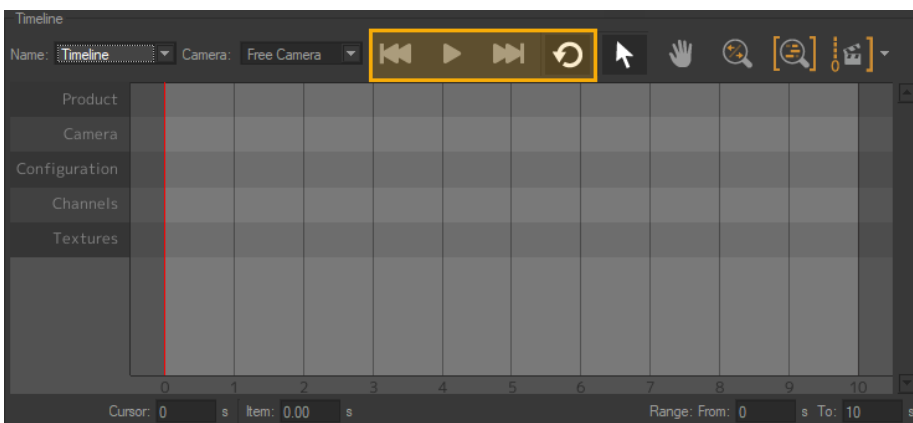

NOTE

The chosen camera is modified by camera clips during timeline playback. The original camera settings will be overwritten.

Timeline Playback Controls



The playback is controlled using the set of playback buttons at the top of the **Timeline Zone**:

Icon	Function	Description
	Timeline range start	Returns the time cursor to the beginning of the animation range.
	Play / Pause	Start the playback if it is stopped, or pause it if it is currently running.
	Timeline range end	Move the time cursor to the end of the animation range.
	Loop timeline playback	Loop the playback of the animation range. This mode is active by default.



TIP



You can also control playback with optional keyboard shortcuts that can be set up in **File > Keyboard Map** editor for the following actions:

- **Timeline Range Start** returns the time cursor to the beginning of the animation range.
- **Timeline Range End** moves the time cursor to the end of the animation range.
- **Play/Pause Timeline Playback** starts the playback if it is stopped, or pauses it if it is currently running.

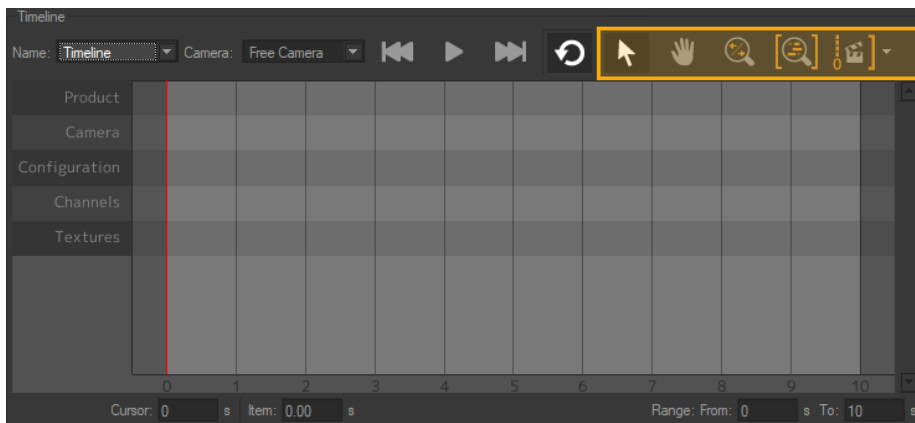
Navigation Controls for Timeline Tracks





To move within the timeline tracks:

- Use the scroll wheel of the mouse to zoom in on and out from the mouse cursor position.
- Click on the buttons at the top of the **Timelines** editor corresponding to the mouse modes, then move the mouse while holding down the left mouse button:
 - **Select and move**  an item.
 - **Pan**  the track display zone.
 - **Zoom** .

- Use the shortcuts configured in the **Keyboard Map** editor. By default, you can:
 - Pan: by holding down the middle mouse button and moving the mouse,
 - Zoom: by holding down **Ctrl + Shift** + the middle mouse button and moving the mouse.



The  button in the upper right-hand corner resets the level of zoom to fit the width of the entire playback range in the display zone.

The button  in the upper right corner adjusts the animation range with the timeline content from 0 seconds until the last channel.

The button  in the upper right corner adjusts the animation range with the content of the timeline from the start of the first channel to the last.

Precise Positioning Controls

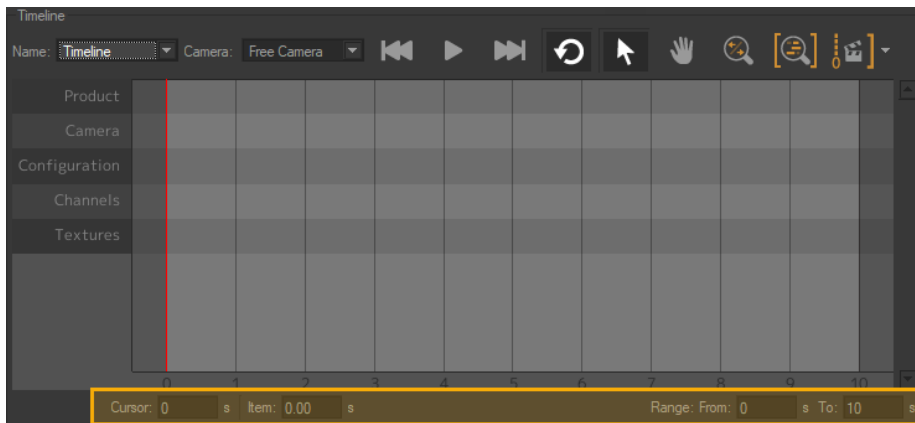





This bottom of this zone also allows you to:

- Position the time cursor as precisely as possible by providing its temporal position in seconds in the **Cursor** Time box. You can also drag the cursor with the mouse.
- Position the selected item or group of items in the animation tracks as precisely as possible by providing its activation time in seconds in the **Item** time box.
- Define the animation range, or the playback start and end times in seconds, by specifying values in the **Range:From** and **To** boxes.

Timeline Library

The libraries on the right-hand side of the **Timelines** editor include a tab for the list of **Timelines** . From this list you can select the timeline animation to edit by clicking on its name. The selected timeline's contents and settings are shown in the **Timeline** editing zone on the left of the **Timelines** editor. Only one timeline can be selected at a time.

Use the buttons to manage the list:

Icon	Function	Description
	New	Create a new timeline.
	Duplicate	Duplicate the selected timeline.
	Rename	Rename the selected timeline. Give each timeline a unique name.
	Delete	Delete the selected timeline.



NOTE

You must have at least one timeline in the **Timelines editor**. The **Remove** button will be grayed out if the selected timeline is the only timeline in the list.

Product Library

The products in your database can be loaded into any timeline as product keys. For quick access from within the **Timelines** editor, the libraries on the right-hand side include a **Products**  tab that lists all of the products in the open database.

From the **Products** library, you can load database products as product keys by dragging products from the library and dropping them onto the **Product** track.



TIP

Products can also be dragged directly from the **Matter** sidebar's product library.

The first product key will be used to determine the initial product shown in your timeline. If you have not added any product keys, the product in the active viewport will be displayed instead.

Camera Animations Library

Camera animations provide the source content for clips in the **Camera** track of a timeline. The **Camera Animations**  tab in the library, located on the right-hand side of the **Timelines** editor, consists of a list of predefined camera animations. It provides buttons that allow you to create new ones, duplicate, rename, or delete the current ones.

From the list in this library tab, you can:

- Load camera clips by dragging animations from the library and dropping them onto the **Camera** track. Dropping a camera animation onto the **Camera** track creates a solid-colored clip whose length corresponds to the duration of the clip. In a bookmark animation clip, the positions of the bookmarks are visible. Each bookmark is displayed as a vertical bar within the clip.



NOTE

The initial camera position of the first clip will be used from the beginning of the timeline. If no clips exist in your timeline, the camera position in the active viewport will be used instead.

- Modify an existing animation by double-clicking on its name in the list.

Use the buttons to manage the list:

Icon	Function	Description
	New	Create a new camera animation. You will be asked to provide a name for the new animation and to select the type of camera path (Kam file, bookmark animation or Bézier path) from the drop-down list.
	Duplicate	Duplicate the selected camera animation.
	Rename	Rename the selected camera animation.
	Import	Import a camera animation in the following formats: KBA (bookmark animator), BZA (Bézier paths) and KAM (KAM file).
	Export	Export a camera animation in the following formats: KBA, BZA and KAM.
	Delete	Delete the selected camera animation.

Configuration Keys Library



NOTE

If you are working with a multi-product database, please note that configurations will apply to the first product in your product list only. If a different product is animated in the **Product** track, the configuration keys activated during that period will appear to have no effect.





Configurations set up in your database with the **Configuration** system can be animated on the Configuration track in any timeline.

To animate configurations, configuration keys need to be created in the **Configuration Keys**  library tab on the right-hand side of the **Timelines** editor. This tab contains a list of existing configuration keys and buttons allowing you to create new ones and duplicate, rename, or delete the current ones.

From the list in this library tab, you can:

- Add a configuration key to the **Configuration** track by dragging it from the library and dropping it onto the track.
- Modify an existing key by double-clicking on its name in the list.

Use the buttons to manage the list:

Icon	Function	Description
	New	Create a new configuration key. This will open the Configuration Key editor, where you can provide a name for the key and set the configuration it corresponds to.
	Duplicate	Duplicate the selected configuration key.
	Rename	Rename the selected configuration key.
	Delete	Delete the selected configuration key.



NOTE

If you do not have a configuration key or its colored influence zone at the beginning of your timeline range, the initial configuration will be adopted from the global configuration set in the **Configuration Browser**. During the playback, the **Configuration Browser** will be updated with the configuration changes imposed by the configuration keys.

This allows the initial configuration in your timeline to vary. Consequently, looped playback and configuration manipulations done in the **Configuration Browser** can be used to create variations in the playback at the beginning of your timeline.

If this is not the desired behavior, initialize your timeline with a configuration key placed at the beginning of the playback range. In the **Configuration Key Editor** [175], make sure that this configuration key imposes a value other than the default **Keep previous** value for each of the symbol selections.

Channel Clip Library

Channels allow diverse elements of your Digital Aspect Mockup to be animated. Channels exist for:

- Animated geometries set up in the **Kinematics** tab of the **Shaper** sidebar.

For freely transformable parts, six different channels control the animation of a part: the angles of rotation around the three axes (X, Y, and Z) and the distances of translation along the three axes (X, Y, and Z).

For rotating and translatable parts, a single channel controls the animation of the part: the angle around the rotation axis in the case of a rotation, or the distance along the vector in the case of a translation.

- The intensity and color of the lighting layers,
- Animated meshes,
- Most modifiable options for any type of material,
- Lighting environments,
- Real-time sun settings,
- Overlays,
- Post-processing.

A material, environment, overlay, or post-processing effect must be used in the active product for its channels to be available for animation.





To add channel-based animations to a timeline, create channel animation clips in the **Channel**

Animations  library tab on the right of the **Timeline editor**. This tab is made up of a list of existing channel animation clips and buttons to create, duplicate, rename and delete clips.

From the list in this library tab, you can:

- Add a channel animation clip to any **Channel** track by dragging it from the library and dropping it onto the track.
- Modify an existing clip by double-clicking on its name in the list.

Use the buttons to manage the list:

Icon	Function	Description
	New	Create a new channel animation clip. This will open the New Channel Selector window, where you can provide a name for the clip, select the channel or channels that will be animated in the clip, and select the desired type of control over the animation: Standard (basic, single-channel animation) or Advanced (custom, multi-channel animation).
	Duplicate	Duplicate the selected channel animation clip.
	Rename	Rename the selected channel animation clip.
	Delete	Delete the selected channel animation clip.

Texture Library

The video textures in your database can be added to any timeline as texture clips. For quick access from within the **Timelines** editor, the libraries on the right-hand side include a **Texture** tab that lists all of the video textures in the open database.

From the **Textures** library  you can load a texture as a clip by dragging and dropping from the library. Drop the clip on a **Textures** track.

**TIP**

Textures can also be dragged directly from the **Matter** sidebar's texture library.

When the timeline is played, the video will be animated simultaneously in all materials using it that are assigned to surfaces in the active viewport.

Aspect Layers (Editor)

Available in: **Matter: Editors > Aspect layers**

Aspect Layers is an editor that organizes the aspect of a product in layers. Different materials and their UV mapping projections can be assigned to the same surface in different layers. Using aspect layers will allow you to create configurations for the materials used to dress your product.

This editor consists of three tabs that can be used to manage the aspect layers, the visibility bookmarks and the material assignment method.

The **Product** field identifies the active product.

The **Layer** tab is for configuring the aspect layers.

The **Bookmark** tab is for creating bookmarks associated with the aspect layers.

The **Assignment** tab is for defining the method for assigning materials, specifying which aspect layer and affectation mode should be used when materials are applied.



Layer Tab

Layers: List of aspect layers that have been created.



 : The visibility toggle button is for enabling/disabling visibility of the aspect layer. When the visibility button is disabled for a group of aspect layers, none of the layers in the group are visible, but layers keep their own state.

 : The lock toggle button is used to lock/unlock one or more aspect layers or a group of aspect layers. Once locked, the aspect layers are protected from any change. This prevents you from accidentally modifying a finalized appearance layer configuration that does not require further modification. A locked layer can no longer be activated until it has been unlocked.

 : This icon indicates the active aspect layer(s).









Icon	Function	Description
	Pick active aspect layer	Select the aspect layer associated with the material of the surface you click in the viewport.
	New aspect layer	Create a new aspect layer in the list of layers.



Icon	Function	Description
	Duplicate the selected item	Create a copy of the selected element: aspect layer (s) or group of aspect layers.
	New group	Create a new group of aspect layers.
	Merge Layer Selection	Combine the selected layers into a single layer.
	Flatten all layers	Combine all layers into a single layer.
	Delete aspect layer	Delete the selected layer.
	Split layer by picked material	Assign a new aspect layer to the picked material.
	Split layer by stickers	Assign a new aspect layer to the picked sticker.
	Split layer by visibility	Create an aspect layer, skipping the surfaces hidden in Shaper . Only the surfaces that are visible will be taken into account. (Switch to Evaluate active layer only to enable this function.)
	Explode layer selection by assignment	Partition products in layers that have common material assignments.
	Explode layer selection by material	Divide an aspect layer by the number of materials constituting it. The names assigned by default to these new layers are those of the materials.
	Import aspect layer	Import aspect layers from another product.
	Flatten all layers in new product	Create a new product using all aspect layers.
	Evaluate all layers in stack	View the product by taking all aspect layers into account.
	Evaluate layers stack until active layer	View the product by taking into account the lowest level of aspect layers up through the active layer only. A red border around the viewport indicates that the view is restricted to a limited selection of layers.
	Evaluate active layer only	View the active aspect layer only.
	Highlight active layer assignments	Enable/disable highlighting of surfaces with a material in the active aspect layer.
	Hide surfaces without assignment	Hide/show surfaces that have no material assigned to them.

Icon	Function	Description
	Copy Selected Layers To Active Layer	 NOTICE Copy the selected layers to the active layer.
	Replace String	Rename a selection of layers and assign a prefix and/or suffix to them.

The **Layer** field is for renaming the active aspect layer.

Right-clicking on an aspect layer opens a context menu with the following functions:





Icon	Function	Description
-	Select visible layers	Select visible layers.
-	Invert layer selection	Invert layer selection.
-	Hide selected layers	Hide layer selection.
-	Show selected layers	Show layer selection.
	Lock the selected layer(s)	Lock layer selection.
	Unlock the selected layer(s)	Unlock the layer selection.
	Merge Layer Selection	Combine the selected layers into a single layer.
	Split layer by picked material	Assign a new aspect layer to the picked material.
	Split layer by visibility	Create an aspect layer, skipping the surfaces hidden in Shaper . Only the surfaces that are visible will be taken into account. (Switch to Evaluate active layer only to enable this function.)
	Split layer by stickers	Assign a new aspect layer to the picked sticker.
	Explode layer selection by material	Divide an aspect layer by the number of materials constituting it. The names assigned by default to these new layers are those of the materials.
	Explode layer selection by assignment	Partition products in layers that have common material assignments.
	Flatten all layers	Combine all layers into a single layer.

Icon	Function	Description
	Flatten all layers in new product	Create a new product using all aspect layers.
	Copy Selected Layers To Active Layer	Copy the selected layers to the active layer.

Bookmark Tab

The **Bookmark** tab is for creating bookmarks according to the visibility state of the aspect layers.

Layer Visibility Bookmarks: Lists the bookmarks of layer visibility configurations that have been created. Double-click on a bookmark to enable it.

Icon	Function	Description
	New aspect layer bookmark	Create a new bookmark in the list of aspect layer visibility bookmarks. A bookmark is a saved set of the elements visible in the current configuration of layers.
	Store aspect layer bookmark	Update the active bookmark by storing the current aspect layer configuration.
	Restore aspect layer bookmark	Display the configuration saved in the active bookmark. this function can also be accessed by double-clicking on the bookmark in the list.
	Delete aspect layer bookmark	Delete a bookmark from the list of visibility bookmarks.

The **Bookmark** field is for renaming the active visibility bookmark.

Assignment Tab

The **Assignment** tab is for configuring the mode of assignment of the aspect layers.

Parameter	Description
Target	Set whether a material being assigned should be applied to the active aspect layer or to the layer to which the current visible material belongs.
Assign as	Sets the default assignment mode for the layer. This determines whether a material should be assigned by default as a material or as a sticker.

 **NOTE**
For an aspect layer dedicated to stickers, setting the default assignment mode to **Sticker** will prevent you from applying material types (matte, mirror) that cannot be used as stickers.

Parameter	Description
UV reset	Indicate whether the UVs should be reset to 0.0 (yes) or used as-is (no) during assignment.
Affectation mode	Choose whether to use the assignment mode Assign or the mode Replace .



The **Reset** to default button is used to restore the default parameters.

Position Layers (Editor)







Available in: **Shaper** or **Matter** > **Editors** > **Position layers**



Position Layers is an editor used to create layers in which the position of **Shaper** objects can vary. Position layers can then be used by the configuration system to create variants of models or products in which the position of certain objects is modified.

The **Position Layers** editor consists of a **Layer** tab in which there is a list of existing position layers. The position layer named **Base** layer is present by default.

Each position layer in this list has a visibility toggle button for enabling and disabling visibility. The symbol  indicates which position layer is visible. When a layer is hidden, the symbol  is displayed. The  icon indicates the active position layer. In order to make a position layer active, click within the check-mark column beside the layer you want to make active.

The following operations can be performed on position layers:

Icon	Function	Description
	Pick Active Position Layer Mode	This command is for selecting the position layer associated with the position of the clicked surface from the viewport.
	New Position Layer	A new position layer is created and added to the list of layers.
	Duplicate Position Layer	This command creates a copy of the selected position layer. The base layer cannot be duplicated.
	Merge Layer Selection	This command merges selected position layers.
	Delete Position Layer	The selected position layer is deleted. The base layer cannot be deleted.
	Evaluate all layers in stack	This command displays the product taking all position layers in the list into account.
	Evaluate Layer Stack Until Active Layer	This command displays the product taking into account the selected position layer and the layers lower in the hierarchy only. A red border around the viewport indicates that the view is displayed with a restricted list of position layers.

Icon	Function	Description
	Evaluate Active Layer Only	This command is for restricting the visibility of the position layers to the selected layer.
	Highlight active layer assignments	This command enables/disables highlighting of surfaces that have an assignment in the active position layer.
	Hide Surfaces Without Assignments	This command enables/disables the displaying of the surfaces without an assignment.

The **Layer** field of the **Layer** box at the bottom of the editor is for renaming selected position layers. It should be noted that the **Base Layer** cannot be renamed.

Cameras (Editor)

Available in: **Matter** or **Shaper: Editors > Cameras**











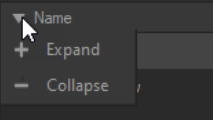







Cameras is an editor that contains two parts: the list of cameras that are available in your database, and the zone that displays the properties of the camera being edited.









Camera List

The camera list is organized in a hierarchy composed of groups and cameras. Each group can contain both cameras and other groups. The elements in the hierarchy – cameras and groups of cameras – can be moved within the hierarchy by drag-and-drop.

You can select a camera from the camera list to edit or to activate in the current viewport.

Icon	Operation	Description
	Expand/ collapse the camera tree	Click the arrow to expand or collapse the list of cameras tree.
-	Activate a camera	Click on a camera to recall its settings in the current viewport.
	Edit current camera	Double-click on a camera from the list or click on the icon  just below the camera list to view and edit the camera settings in the right part of the editor. In this mode, navigating in the viewport changes the camera settings.
	Show/Hide cameras	Shows or hides cameras in the viewport of Matter or Shaper .

Icon	Operation	Description
	Unlock/Lock the position of the cameras	Unlock or lock the position of the cameras in the viewport. <div data-bbox="687 309 1450 562" style="border: 1px solid #ccc; padding: 10px; margin-top: 10px;"> <p> NOTE By locking the position of one or more cameras you will no longer be able to change its parameters such as the Depth of field or the Motion blur.</p> </div>
Icon	Operation	Description
	Enable or disable the Edit current camera mode	The camera currently being edited is marked with this icon  in the Camera List . If no camera is marked with this icon, the viewport's free camera information is shown and can be edited on the right-hand side of the editor.
	Update camera settings with the settings used in the active viewport	
	Reset active camera settings	Only the camera settings will be reset, not the position.
	Open a floating viewport attached to the selected camera from the list	The selected camera in the Camera list opens in a floating viewport. A blue frame indicates that the current camera is in edit mode. See Changing camera settings [442] for more information. <div data-bbox="687 1234 1450 1451" style="border: 1px solid #ccc; padding: 10px; margin-top: 10px;"> <p> NOTE Any viewport of Shaper or Matter can be attached to the camera to display what the selected camera frame.</p> </div>
	Add a new camera	The camera is initialized using the settings in the current viewport.
	Add a camera group	
	Duplicate a camera or a group of cameras	
	Rename a camera or a group of cameras	

Icon	Operation	Description
   	Assign selected camera as one of the product's favorite cameras	The selected camera is assigned to the favorite camera you select for the product in the active viewport. Cameras marked as favorites for the product in the active viewport are displayed in the Camera List with the icon  .
	Delete a camera or a group of cameras	If you attempt to delete a camera currently assigned to a viewport, an alert will appear informing you of the camera's current use. If you confirm that you would like to delete the camera, the viewport will return to its free camera.
	Import a camera or group of cameras in the KCH or KBE format	This option also allows you to generate cameras from a .kam file. See Generating cameras from a .kam file [445] .
	Export a camera or group of cameras in the KCH format	

Use the buttons below to manage the cameras in the hierarchy.

A right-click on a camera or a group of cameras opens a context menu. In addition, to list the operations above, this menu has one more. You can assign the same sensor to your selection with  **Assign sensor** parameter.

Still from the contextual menu, you can also move a camera outside a group of cameras with the  **Move to root** option.

You can also assign a sensor to multiple selection of cameras by dragging and dropping a sensor from the **Sensor Library** to the **Cameras** editor.



NOTE

If you assign a sensor to a group of cameras, the sensor will be automatically applied recursively to all its cameras and subgroups.

Editing Camera Properties

The right-hand side of the editor displays the settings of the camera being edited. Select a camera from

the list on the left by clicking on it and enabling the  **Edit current camera** mode to view or edit the camera settings in the right-hand side of the editor. You can also double-click on the camera.



WARNING

In this mode, navigation in the viewport will also modify the camera's settings.

If no camera is selected for editing, the settings for the active viewport's free camera are displayed.

You can click in the field you would like to modify and provide a new value.

Renaming the Camera

The name of the camera being edited is shown. You can modify it by clicking within this zone. It is also possible to use the button below the camera list to rename the camera.

Choosing a Sensor

To modify the associated sensor, drag a sensor from the Matter sidebar's sensor library and drop it on the **Sensor** field.

To remove a sensor from the camera, click on the  **Remove current sensor** button. This will not delete the sensor. When you remove a sensor, the camera will automatically return the default sensor settings instead.

Lens

The basic camera parameters can be set in the **Photo** tab or the **CG (Computer Graphics)** tab. The **Photo** tab displays the parameters in analog form, using the vocabulary associated with a physical camera as a metaphor. The **CG tab** allows you to provide the same information.

Photo	CG
Focal length: provide the focal length. The sensor size is displayed below this field for reference. Sensor size influences the interpretation of this value.	Field of view (FOV): provide the angle corresponding to the field of view.
Portrait mode: tick this box to impose a portrait orientation. Lenses have a landscape orientation by default.	Field of view axis: from the drop-down menu, choose the axis to which the angle of the field of view should be applied.

Lens Shift

Patchwork 3D has a lens shift allowing you to frame your compositions regardless of their height or width.

The lens shift makes it possible to capture, without perspective distortion and with the same focal length, a composition that would not normally fit into the field of the Patchwork 3D camera. By analogy with cameras, this is very often the case when you want to photograph a very tall or very wide building that does not fit entirely within the frame of the lens. To overcome this inconvenience you must either move away from the subject to enlarge the angle or tilt your camera upwards to photograph the entire building for example. This results in perspectives that may be unwanted.

1. Select a camera from the list on the left by clicking on it and enabling the  **Edit current camera** mode to view or edit camera settings. You can also double-click on the camera.
2. In the upper right corner of the **Cameras** editor, use **Shift X** to correct the framing on the horizontal plane, and **Shift Y** to correct on the vertical plane.



TIP

You can also adjust the lens shift directly from the viewport using the  **Lens Shift** interaction mode available in the toolbar of **Matter**. More information is in the section [Interacting with the 3D Viewports \[92\]](#).



Initial positioning of the car (centered).



The car is moved to the left via

the  **Pan** tool without the shift. The perspective of the car is accentuated.



The car is moved to the left via the  **Lens Shift** tool. The perspective of the car is maintained regardless of its movement to the left.

Depth of Field



NOTE

The **Depth of Field** zone brings together settings that were previously available in the **Depth of Field Editor** for versions up to and including v5.7.

Depth of field is an effect by which objects at the focal distance from the camera appear clearly. Objects at other distances appear progressively blurrier as their distance from the zone in focus increases. This effect can be activated by checking the option **Active**.

By default, the depth of field is also active during navigation within a scene or when playing an animation.



TIP

For the depth of field to be displayed in the 3D viewport, antialiasing must be activated under the **Render Quality Settings** menu accessible from the viewport context menu. See [Render Quality Settings \(Editor\) \[225\]](#).

For an image snapshot, the option **Antialiasing** must be activated in the Snapshot Images editor.

The value provided in the **Aperture** field sets the diameter of the aperture of the lens shutter. The aperture is expressed in millimeters.

The focal distance can be provided here in numerical form. If you prefer to define the focal distance interactively, activate the camera.

Once the camera is active in a 3D viewport, you can define the focal distance by placing the cursor over the zone where the focal point should be positioned and using one of the following keyboard shortcuts:

Shortcut	Action
Ctrl+Spacebar	Places the point indicated by the cursor at the center of the focal plane. This manipulation may change the direction in which the camera is facing.
Shift+Spacebar	Places the point indicated by the cursor at the center of the focal plane. This manipulation may change the direction in which the camera is facing.

The smoothness of the blurriness, or quality, can be modified by moving the slider. A higher value increases the quality but requires a longer calculation time.

Motion Blur

The motion blur effect simulates the streaking effect of moving objects or a moving camera when the object or camera is moving during the time of exposure.

When the **Motion Blur** option is enabled, modifying the camera orientation and position produces a motion blur effect. This simulates the effect of a physical camera with the capture speed (framerate) provided in the **Frames per second** field.

To limit the effects on rendering speed, this effect is applied only to the camera motion by default. To apply it to animated objects as well, check the **Apply to moving objects** option. When applied to moving objects, place the cursor at the appropriate time in the **Timelines** editor to see the effects on a static image.

The motion blur effect is visible in video captures, but is not available in renders by raytracing.

Depth Range

The **Depth Range** box shows the automatically-calculated placement of the two Z planes between which the camera's view is in focus. You can force a different position for the Z-near and the Z-far planes by providing new values.

Point of View

A camera position: the position and the orientation of the camera.

Mode	Description
From-To-Up	Provide the point (X, Y, Z) for the position of the camera, a point along the camera's viewing vector, and a point along the vector indicating the upward vertical axis of the camera.

Mode	Description
Position-Orientation	Provide the point (X, Y, Z) for the position of the camera and its orientation in Euler angles.

Channels (Editor)

Available in: **Matter: Timelines > Channel Animation Clips** library tab > double-click on a clip name
Timelines > Channel Animation tracks > double-click on a clip

Channels is an editor that allows you to set up and rename channel animation clips. The editor will open when you create a new channel animation clip or when you double-click on an existing clip in order to modify it.

Once open, the **Channels** editor will always show the information for the current active clip in the Timelines editor. To change the clip shown in the editor, select a different clip in the Timelines editor using one of the following methods:

- Click on the name of a clip in the **Channel Animation** library tab,
- Click on the representation of a channel animation clip in one of the **Channel** track,
- Create a new channel animation clip using the button below the list of existing clips in the **Channel Animation** library tab. This will create a new clip and activate it. It will also open the **New Channel Selector** window, where you can provide a name for the clip, select the channel or channels that will be animated in the clip, and select the desired type of control over the animation: **Standard** (basic, single-channel animation) or **Advanced** (custom, multi-channel animation). Validating this choice will open the **Channels** editor.

The editor will display different controls depending on which configuration mode you have chosen.



Channel Selector

Available in: **Matter: Timelines > Channel Animation Clips** library tab > **New channel animation**
Timelines > Channels > Channel Selector



The **Channel Selector** determines which channels will be available for animation in a clip. When creating a channel animation clip, you must first select the channel or channels to include in the clip. The **Channel Selector** therefore appears automatically when you create a new clip.

When using advanced configuration, you can also modify the channels in the clip at a later time. To add or remove channels from the clip, open the **Channel Selector** from the toolbar of the **Channels** editor.

The main body of the **Channel Selector** is the hierarchy of channels available for the active product. There are four ways to find a channel:

- Expand the entries in the hierarchy until you reach the channel you want to use. Channels are grouped by type, then by option. If, for example, you want to modify the orientation of an environment called "Studio_Default", expand the nodes **Environment**, **Studio_Default**, and **Orientation**. Select the axis or axes you want to modify.
- Use the animated mesh eyedropper  to pick the animated mesh you want to use. Click the eyedropper, then click the surface in the 3D viewport. This selects the mesh in the **Channel selector**. Expand the mesh to select the **Frame** channel.
- By using the material eyedropper  to pick the material in which the channel you want to use is found. Click on the eyedropper, then click on the material in the 3D viewport. This selects the material in the **Channel Selector**. Expand the material in order to view its channels and select the pertinent ones.
- By using the transformation eyedropper  to pick the part that will undergo the transformation you want to use. Click on the eyedropper, then click on one of the surfaces of the part in the 3D viewport. This selects the first parent of that surface in the **Kinematics** tab in **Shaper**.

To add a channel, click within the selection column next to the name of the channel, or right-click on the channel and select **Add channel** from the context menu that appears. The same actions will remove a channel that has already been added: to remove a channel, click in the selection column of a selected channel or right-click and select **Remove channel** from the context menu that appears. The selection column lists the status of each channel:

Icon	Description
	Channel included in the clip.
	Channel excluded from the clip.

Multiple channels can be added to the clip at once. Highlight the channels you want to add by clicking on their names while holding down **Shift** to select a range of channels or **Ctrl** to select separate individual channels. Right-click to open the context menu and select **Add channel** to select these channels, or **Remove channel** to deselect them.





Once you have selected the channel or channels to add to the clip, choose the configuration mode. If you have selected only one channel, you will be able to select **Standard** configuration if you prefer. Multi-channel clips, however, must be configured in **Advanced** mode.

Standard Configuration

The standard configuration of an animation clip is a single-channel mode that gives you access to all of the parameters needed to animate a channel. The speed of the animation is calculated automatically based on the range of the change and the duration of the clip. Both the interval of values for this channel (the range) and the duration are set in this editor.

At the top of the editor, a text field displays the name of the clip. It can be edited directly in this field. Use the **Enter** key to validate your changes.

Below the name of the clip, the following settings are available:

- **Initial value** of the animated parameter,
- **Final value** of the animated parameter,
- **Duration** of the clip in seconds,
- **Easing**. The value of this option smooths the animation so that the beginning, the end, or both appear less abrupt. Choose from the following options:
 - **Linear** : The development of the animation will be linear. No easing is added.
 - **Ease in** : Easing is added at the beginning of the animation.
 - **Ease out** : Easing is added at the end of the animation.
 - **Ease in and out** : Easing is added at the beginning and at the end of the animation.

Depending on the channel select, the initial and final positions are expressed:

- in the Patchwork 3D **default units [63]** for translation and other distances,
- in degrees for rotation and other angles,
- in whole numbers from 0 to 255 for colors,
- in decimal numbers between the minimum and maximum values for other parameters such as intensity,
- in 0 (disabled) or 1 (enabled) for the state of a binary parameter.

Using Preset Values for an Animated Mesh

Choosing an animated mesh and the standard configuration mode allows you to automatically replicate the animation exactly as it was prepared in Autodesk Maya or Autodesk 3ds Max.

1. In the **Timelines** editor's **Channel Animation Library**, create a new channel animation.
2. The **Channel Selector** will appear. Select the animated mesh you want to use. You can use the mesh eyedropper  to pick the mesh directly from the viewport. Do not select any other channels.
3. Select **Standard** configuration.

The animation parameters for the mesh are initialized with the values taken directly from the imported settings that were established in Autodesk Maya or Autodesk 3ds Max:

- **Initial value**: frame 0, the first frame of the animation,
- **Final value**: frame N, the last frame of the animation,
- **Duration**: the original length of the animation, expressed in seconds,
- **Easing**: linear.

Advanced Configuration

Advanced configuration of a channel animation clip handles the animation of multiple channels at once. It also gives you direct control over the temporal development of the animation using points placed









along a graph representing time on the X axis and the range of animation of the part on the Y axis. This produces a curve representing the development of a given channel over time. Each channel has its own curve.

The Y-axis is expressed in the default units for the selected channel:

- in the Patchwork 3D **default units [63]** for translation and other distances,
- in degrees for rotation and other angles,
- in whole numbers from 0 to 255 for colors,
- in decimal numbers between the minimum and maximum values for other parameters such as intensity,
- in 0 (disabled) or 1 (enabled) for the state of a binary parameter.

At the top of the editor, a text field displays the name of the clip. It can be edited directly in this field. Use the **Enter** key to validate your changes.













The operations toolbar above the graph provides the following tools:

Icon	Function	Description
	Selection	Use this mode to select points placed along the curve.
	Pan	In this mode, the mouse is used to move the curve so as to display the section you are interested in. This does not change the scale of the graph.
	Zoom	In this mode, the mouse is used to zoom in or out on the curve, changing the scale of the graph.
	New key frame	In this mode, clicking places a new key frame along the curve.
 TIP A new key frame can also be added by holding down Alt and clicking when using any of the modes to select and move key frames (see below).		
	Select and change value	Dragging a key frame changes the value, but not the time. You can also provide a exact value in the Value field.
	Select and change time	Dragging a key frame changes the time of the point, but not the value that has been set. You can also provide a exact value in the Time field.
	Select and move	Dragging a key frame changes the time and the value. You can also provide its exact time and value in the corresponding fields.



NOTE

For any two key frames, increasing the time (horizontal distance) between them will make the animation slower. Increasing the difference in values (vertical distance) will make the change more pronounced.

Icon	Function	Description
	Key Frames editor	<p>Provides access to the key frame options:</p> <ul style="list-style-type: none"> • Current key frame, •  Previous key frame, •  Next key frame, • Key frame Time (horizontal position), • Key frame Value (vertical position), • The variations of a channel's value between two successive key points over time are represented by curves. The forms of the curves to the Left and to the Right of a key frame can be one of the following types: <ul style="list-style-type: none"> • Curve type  (default), • Linear  type, • Step type . <p>The form chosen at a key point for the curve to the left of the point is applied to all of the curve starting from the previous key frame. Likewise, the form chosen at a key point for the curve to the right of the point is applied to all of the curve until the next key frame. If another form was previously applied at a different key point for the same segment of curve, it will be overridden by the current choice.</p>
	Capture current values	Places new key frames at the time cursor position for each of the selected channels. Each key frame is positioned at the current value for its channel in the active viewport.
	Capture RGB values	When the curves for the R, G, and B channels of a color parameter are selected, this button appears. It can be used to open the color picker, in which you can select a color for the parameter. Once the choice of a new color has been validated, the new R, G, and B values are placed at the time cursor's position on the corresponding curves. If key points do not already exist at this location, they will be created for the new values.
	Channel Selector	Allows you to modify the channels used in this clip.
	Zoom to fit	Zoom to adjust the scale to fill the display area with the curve, vertically and horizontally.
	Zoom to fit (selection)	Zoom to adjust the scale so that the selected key frame and curve segments fill the display area.
	Zoom to fit (horizontal)	Zoom to adjust the scale so that length (time) of the curve fills the display area.
	Zoom to fit (vertical)	Zoom to adjust the scale so that the height (changes in position or orientation) of the curve fills the display area.

To the left of the graph, the list of all of the available curves is displayed. By default, all of the curves are selected. Modify the selection by clicking on the names of the curves. Only the selected curves are visible on the graph.

The color of a curve can be customized. Right-click on name of the curve and choose **Change curve color** to open the color chooser.



TIP

To check the name of a curve on the graph, hover over it with the mouse cursor. Its name will be displayed in the information bar at the bottom of the main window.

Below the graph, you have options to provide the maximum **duration** in seconds of the animation, and an indicator of the cursor's current position in the **Mouse at** field.

Sensors (Editor)





Available in: **Matter**:

- Sidebar sensor library > **New Sensor**
- Sidebar sensor library > **Edit the Selected Sensor**
- **Editors > Sensors**

The interface is organized into two functional zones:

- Operations toolbar and sensor name,
- Sensor settings.

The operations toolbar contains the basic operators for sensors:

Icon	Description
	Drag the sensor that is currently being edited from this point and drop it onto a 3D viewport to use it.
	Select the eyedropper, then click on a 3D viewport. This sets the sensor used in that viewport as the current active sensor and allows it to be edited.
	Click on this button to create a new sensor.
	Click on this button to duplicate the sensor currently being edited, whose settings are shown in the editor. The new sensor is activated as soon as it is created.
Text field	The text field indicates the name of the active sensor. Click in the text field to modify the sensor's name and validate your changes with the Enter key when you have finished.

Choose the projection type. By default, a sensor is created in perspective mode, but you can activate the isometric mode instead by ticking the **Isometric projection** checkbox. Isometric projections are used in

industrial drafting: there is no perspective and the dimensions are not modified by the distance to the viewpoint. When the isometric mode is active, the options in the **Aspect Ratio** zone are grayed out. This zone contains settings that are not applicable to an isometric projection.

If you set up a camera in perspective mode, you can set the sensor size in the **Aspect Ratio** zone:

- **Aspect preset:** Select an option from the drop-down list. You can choose from among common formats (such as 16:9) or select the option to define your own format. To the left, the **Sensor size** field displays the equivalent size in terms of a sensor of a physical camera (such as 36x24).
- If you have chosen a **custom** ratio in the list of presets, provide the ratio you would like to use as a ratio in the **Aspect ratio** field or in camera sensor sizes in the **Sensor size** field. Some sensor sizes are preset for you; you can choose one of these in the **Preset** drop-down menu if you have chosen a preset aspect ratio.

Overlays, backgrounds, and post-processing effects are applied to the sensor. To apply an effect, drag it from its library in the **Matter** sidebar and drop it in the corresponding field in this editor. You can remove the application of an effect to a sensor by clicking on the **Remove** button beside the effect.

Snapshots (Editors)

Available in: **Matter: Snapshot > Snapshot Image / Snapshot Videos / Snapshot Cubic VR Objects / Snapshot Cubic VR Panoramas**

The five snapshot editors capture the rendering in a viewport and use it to generate a high-definition image, video or 3D environment. Each editor is adapted to its specific media format: images, videos, 360-degree videos, 3D virtual reality objects, or virtual reality cubic panoramas of 3D spaces.

All five editors, however, have the same structure and many shared settings.

Once all of the settings have been defined, click on the **Render** button to start the generation of each snapshot used to compose the required output.

In this section:

Shared Settings

Dimensions of the Media Output

The dimensions and resolution for the image to be rendered are provided in the **Dimensions** zone.

The **Format** drop-down list, available for all types of snapshot except cubic VR panoramas, provides access to the most commonly-used sizes and formats. Certain formats, such as **User Defined** or **User Defined in Units** allow the dimensions to be provided directly as values. By default, Patchwork 3D proposes the format **Defined by Viewport**.

Custom formats can be added to this list from the **User Presets** tab in the Patchwork 3D **Settings**.

Rendering Engine

Each editor offers the choice of rendering engine to use: **OpenGL**, **GPU Ray tracing**.

OpenGL

The **Configure** button next to the **OpenGL** radio button opens the **OpenGL Settings** window.

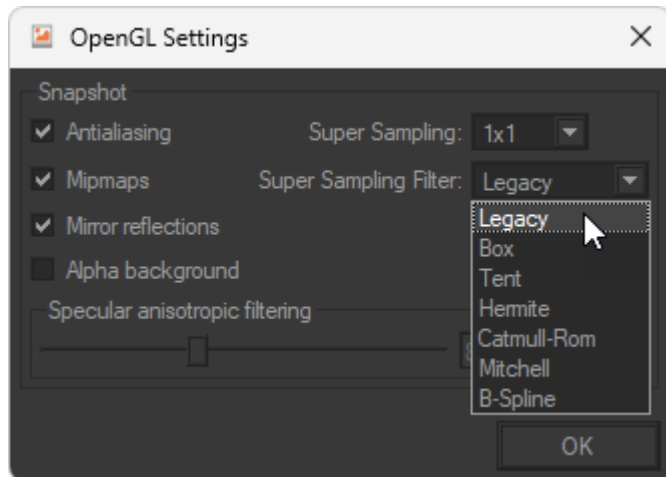

Choose whether or not to apply:

- **Antialiasing**;
- the **Mipmap**,
- **Mirrors reflections**,
- **Alpha background**.

Choose the level of **Super Sampling** from the dropdown list to control the number of samples calculated per pixel when generating images. Increasing the oversampling factor, for example, **2x2**, **3x3**, or **4x4**, reduces artifacts, such as jagged edges, by averaging multiple samples before producing the final pixel value.



NOTICE

Then select the **Super Sampling Filter** to define how the calculated samples are combined to get the final pixel value. Different filters apply different reconstruction methods, influencing edge reconstruction and sampling artifact management. **Legacy** is the default filter that applies the historical reconstruction method used by previous versions to preserve the behavior of existing snapshots. The **Catmull-Rom** filter algorithm is particularly effective as it offers a good balance between image sharpness and the reduction of aliasing artifacts (jagged edges).

Use the slider to define the level of **Specular anisotropic filtering**.

Click on **OK** to save your changes.

Raytracing

The **Configure** button next to the **GPU Ray tracing** radio button opens the **Raytracing Settings** window. For more information on these settings, see the chapter [Raytracing Settings \(Editor\) \[204\]](#).

Files

The **Files** zone contains the controls for the creation of an image file.

In this zone you can set:

- The output directory where the image file will be saved, as well as the name of the file and its extension,
- Whether to **Open File Selector** or not when rendering. When **Open File Selector** is selected, clicking on the **Render** button will show the dialogue box offering the choice of file name and type. This option is selected by default.



NOTE

Image rendered for VR objects and for cubic VR panoramas are saved in the **Snapshots** directory by default.

The following file formats are supported for video output:

- .jpg
- .png
- .bmp
- .tif
- .exr
- .hdf
- .psd
- .psb

The following file formats are supported for video output:

- .avi
- .png
- .jpg
- .bmp
- .tif
- Whether to **Confirm Overwrite** or not when rendering. When **Confirm Overwrite** is selected, if a file with an identical name is detected, P3D Conf Explorer requests your confirmation before replacing it with the file being created. This option is selected by default.
- The **configuration of the compression** according to the file type,
- The **configuration of the layered export** for .psd files.

**NOTE**

Images with an alpha layer must be saved as .png files to keep their transparency. In these cases, the format PNG is automatically proposed by default.

Compression

Click on the **Configure Compression** button to open the **Compression** window.

The compression is adjustable for each type of file to export. For each type of file, the higher the value, the better the quality.

- **JPEG**: slide the cursor to define the compression.
- **PNG**: slide the cursor to define the compression. Tick the **Export as 16 bits** checkbox if you want to activate this option.
- **Image Compression for Animations**: slide the cursor to define the compression.
- **Image Compression for VR Objects and Cubic VR Panoramas**: slide the cursor to define the compression.

If you are configuring compression for a multilayer image, use the **PSD or PSB** options. The options available for multilayer image compression are:

- **No compression**: the output file will not be compressed,
- **RLE**: RLE compression mode is used,
- **ZIP**: output file is compressed using the ZIP format.

To export as a file using 16 integer bits, check **Export as 16 bits**. By default, export is performed using 8 integer bits. Floating point formats (with 16 or 32 bits) are not available.

Layered Image Options

The functionality of exporting captures in PSD or PSB file format allows you to export different layers of a view. Each of the exported layers is saved to a layer in the PSD or PSB file.

Snapshot with OpenGL or Raytracing rendering engine

To export a multilayered image, click the button **Configure Layered Export** to open the **Layered Images Options** window, then choose the layers to add to the PSD or PSB file from the following layers:

- **Composable Image** containing three layers: a background, a multiplicative layer, and a layer of the product's opaque surfaces,
- **Composited Image**,
- **G-Buffer**,
- **Wireframe**,
- **Z-Buffer**,
- **Lightmaps**.



NOTE

The settings defined in this window apply to images exported as PSD or PSB file formats only.

The maximum size supported by the PSD file format is 30,000 pixels in any dimension with a maximum weight of 2 GB.

The maximum size supported by the PSB file format is 300,000 pixels in any dimension.

You can choose to export a layer for each of the following options:

- **Export only PSD or PSB file.** The editor exports the selected layers to a PSD or PSB file format. In Photoshop, layers will be represented as layers.
- **Export only layers as images.** The editor exports the selected layers to individual images. The destination directory will receive all the images of the layers in their respective folders.
- **Export PSD or PSB file and layers as images.** The editor exports both the selected layers to a PSD or PSB file format and to individual images. The destination directory will receive all the images of the layers in their respective folders.

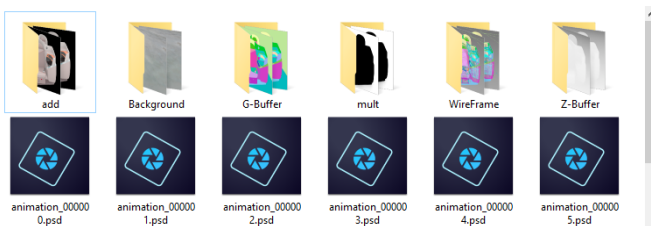

Example of exporting a video using the option **Export PSD or PSB file and layers as images**.

Once the settings have been made click on the button **OK** to save the settings and then press **Render** at the bottom of the editor. In the window that appears name the image and change its file extension to *.psd or *.psb.

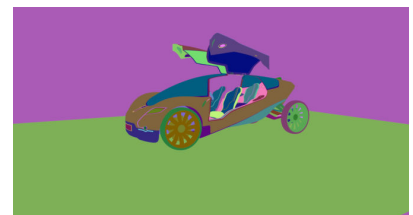

Samples of layers from an exported PSD file: lightmap, wireframe and G-buffer views.





Samples of composable layers and composited image generated using *Composable Image* and *Composited Image* options respectively.

Using Composable Layers

The following composable layers can be obtained using the **Composable Image** option:

- A layer with the background of the snapshot,
- A multiplicative layer. When applied to the previous layer, areas corresponding to transparent surfaces are colored,
- An additive layer which adds opaque areas and reflections on transparent surfaces to the final image.

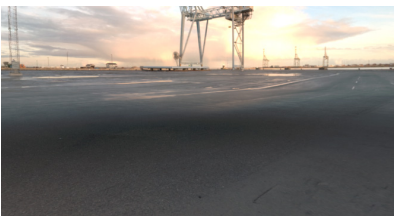

Example of view reconstruction: over the background layer (left) the multiplicative layer (result of the process shown in the middle) is applied. Then the additive layer is applied on the resulting view to reconstruct the final image (right).

The compositing technique described above allows the substitution of the background while maintaining a correct filtering by semi-transparent surfaces. This would be impossible to achieve with a transparency based on an alpha layer.

However, this technique is not compatible with the use of post-processes. Therefore, post-processes are disabled for rendering of composable layers.

Internal Render Info

The **Internal Render Info** zone summarizes various settings. The applicable elements from among following information are displayed:

- **Width** of the image in pixels,
- **Height** of the image in pixels,
- **Pass**, the number of passes to render the image,
- The number of **Frames** to render,
- **Sampling**,
- **Memory**.

Snapshot Process

Various options are available in the **Snapshot** zone, depending on the type of output:

- **Show Info**: displays, along the bottom border of the active viewport, a summary of the dimensions settings of the snapshot.
- **Viewer**: sets the image viewing window to open automatically during rendering.
- **Background**: to open the color chooser. The selected color will be used as a background in the rendering where the view is not entirely enclosed by geometric elements.

Rendering Buttons

Once all of the settings have been defined, click on the **Render** button to start the generation of each snapshot used to compose the required output.

You can also **Add to Snapshot Batcher** to delay rendering until later, or **Replace current Snapshot Batcher item** with the current settings of the open snapshot editor.

Specific Settings for Images

Available in: **Matter: Snapshot > Snapshot Video**

From the **Snapshot** editor, you can modify the rendering parameters and render a view of a product in an image file. This editor uses the material abilities of the interactive viewport to calculate an image whose size can be significantly larger than the screen resolution. The maximum size of the image depends only on your computer's memory.

Once the desired settings have been indicated, the **Render** button initiates the creation of the image file.

Dimensions Zone

The  button next to the **Resolution** box is a shortcut to standard resolutions expressed in dpi (dots per inch). If the resolution is provided in units other than dpi, the chosen standard resolution will be converted to the selected units.

In the **Orientation** zone, select one of the radio buttons for **Portrait** or **Landscape**. This choice is not available if you have selected one of the predefined formats: **Defined by Viewport**, **Defined by Product**, or **Fill Viewport**.

Specific Settings for Videos

Available in: **Matter: Snapshot > Snapshot Video**

Videos exports a timeline as a sequence of frames in a video file. This editor allows you to specify all of the parameters for the conversion of your real-time animation to a frame-based video format that can be saved to your computer and read by common video players.

From **Videos**, you can set the parameters for the conversion from real-time to video file:

- The dimensions,
- The video format, including file name, file extension, codec, and compression,
- The rendering engine to use,
- The timeline that will provide the animation, and the frame rate to apply,
- The frames to include in the video file,
- A preview of the frames that will be created.

Once all of the parameters have been defined, click the **Render** button to launch the rendering of each frame and the production of the video file.



TIP

During rendering, a dialogue box is displayed to show the progression of the creation of the video file. The **Viewer** button at the bottom of this dialogue box opens a frame viewing window.

At any time, you can pause the progression by clicking the **Pause** button, or cancel it by clicking the **Cancel** button. If you have paused the rendering, start it again by clicking on **Resume**.

Dimensions Zone

The dimensions of the animation to be rendered are filled out in the **Dimensions** box.

The **Format** drop-down lists the most common sizes and formats. Some, such as **User-Defined**, allow you to directly set the dimension values. By default, the format **Defined by Viewport** is proposed.

Files Zone

Video formats are defined by three parameters:

- **Container** (file format),
- **Codec** (encoding algorithm),
- **Bitrate** (encoding quality).

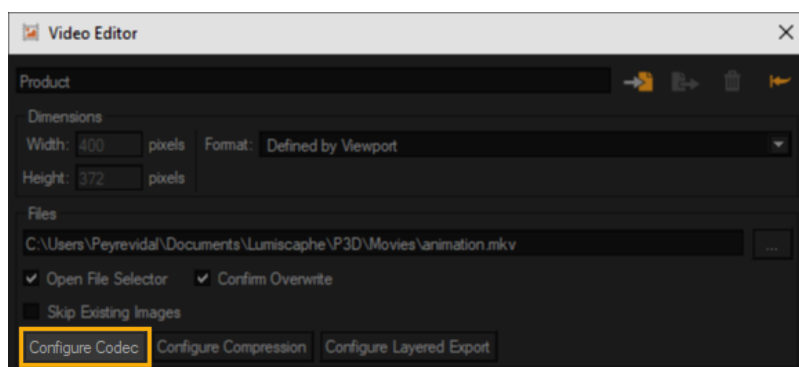

Access to video format settings.

When the **container** is changed, the codecs available in the drop-down list are updated according to the codecs supported by the format.

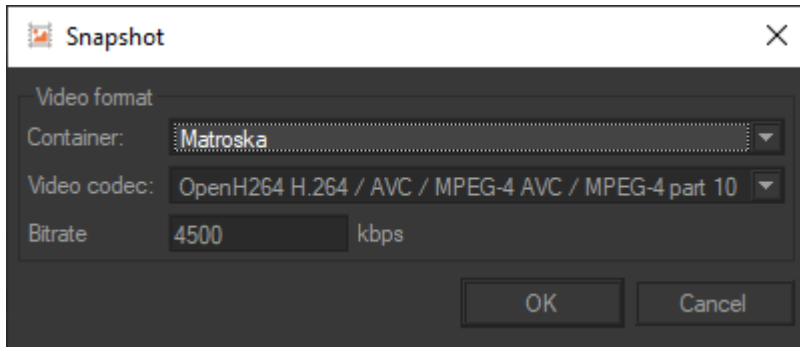

Video format settings.

The available **containers** (formats) are the following:

- AVI (Audio / Video Interleaved) ;
- MKV (Matroska Video) ;
- FLV (Flash Video).

Each video format can embed different encoding algorithms called codecs. Some of them are specific to a format. For example, only Sorenson codec is available for FLV format. Check the documentation of your movie processing software to know which format and codec best fit your needs.

The bitrate defines the amount of data stored to represent the frames. A low value will generate a small-sized file, but visual quality will be low. Conversely, a high value will generate a good quality video but the file will be larger.



Frame samples from videos generated using respectively a low bitrate (on the left) and a high bitrate (on the right).

Timeline Zone

The **Timeline** zone provides the Timeline drop-down list from which you can choose the timeline to be rendered as a video.

Next to the timeline selection, specify the **frame rate** for the conversion from real-time animation to frame-based video.

Frame Output Zone

You have the option to render only a portion of the timeline range by providing the numbers of the desired frames:

- **Current Frame**,
- **All Frames**,
- A **Range** of frames.

It is also possible to indicate the initial number for the index appended to the filename of each frame in the Output Filename zone. By default, the value of this option is "0."

Preview

The **Preview** zone provides a preview of each of the frames that will be rendered.

You can move within the preview sequence:

- By using the buttons to step backwards (←) and forwards (→) one frame at a time in the sequence,
- By providing a frame number,
- By sliding the cursor along the bar.

You can also visualize the sequence by using the **Play** and **Stop** buttons. The frame sequence playback is displayed in the current active viewport.

Tick the **Loop** checkbox to play the video preview in a loop.



NOTE

The editors **Videos** and **Timelines** both use the active viewport to display playback. Consequently, you cannot view playback from both editors at the same time.

If the real-time playback in **Timelines** is playing, you will not be able to play the video preview. Use the controls in the **Timelines** to pause the real-time playback before playing the video preview.

Conversely, if the video preview is playing, you must stop it in **Videos** before running real-time playback from **Timelines**.

Specific Settings for Panoramas

Available in: **Matter: Snapshot > Snapshot Panorama**

Panoramas editor exports a **timeline** [449] as a sequence of frames in a 360-degree panoramic video file. This editor allows you to specify all of the parameters for the conversion of your real-time animation to a frame-based video format that can be saved to your computer and read by interactive video players including YouTube, as well as virtual reality displays.

360-degree panoramic videos differ from standard videos in that the viewer is able to change the direction of view during playback by interacting with the video using a mouse, by changing the position of a mobile device, or by turning her head when using a VR set-up.

From the **Panoramas** editor, you can set the parameters for the conversion from real-time to a 360-degree panoramic video file:

- The dimensions,
- The panoramic settings, including the dimensions in angles of the slices used to compose the 360 degrees of the scene and the choice of mono or stereo feeds,
- The video format, including file name, file extension, codec, and compression,
- The settings for the OpenGL rendering engine,
- The timeline that will provide the animation, and the frame rate to apply,
- The frames to include in the video file,
- A on-screen view of the frames as they are generated.

Once all of the parameters have been defined, click the **Render** button to launch the rendering of each frame and the production of the video file.



NOTE

During rendering, a dialogue box is displayed to show the progression of the creation of the video file. The **Viewer** button at the bottom of this dialogue box opens a frame viewing window.

At any time, you can pause the progression by clicking the **Pause** button, or cancel it by clicking the **Cancel** button. If you have paused the rendering, start it again by clicking on **Resume**.

Dimensions Box

The dimensions of the animation to be rendered are filled out in the **Dimensions** box.

The **Format** drop-down lists the most common sizes and formats. Some, such as **User-Defined**, allow you to directly set the dimension values. By default, the format **Defined by Viewport** is proposed.

Configuring the Codec

Video formats are defined by three parameters:

- **Container** (file format),
- **Codec** (encoding algorithm),
- **Bitrate** (encoding quality).

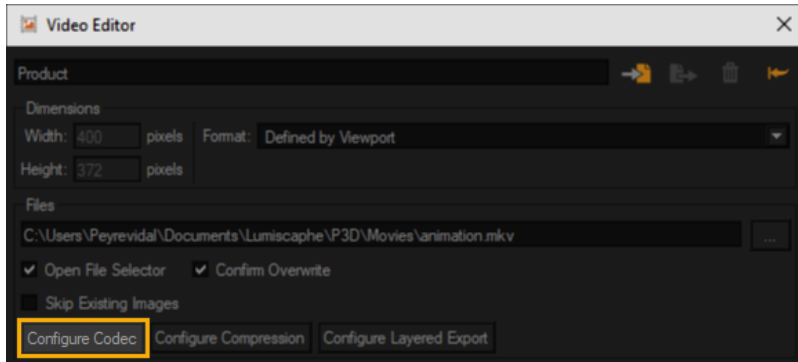

Access to video format settings.

When the **container** is changed, the codecs available in the drop-down list are updated according to the codecs supported by the format.

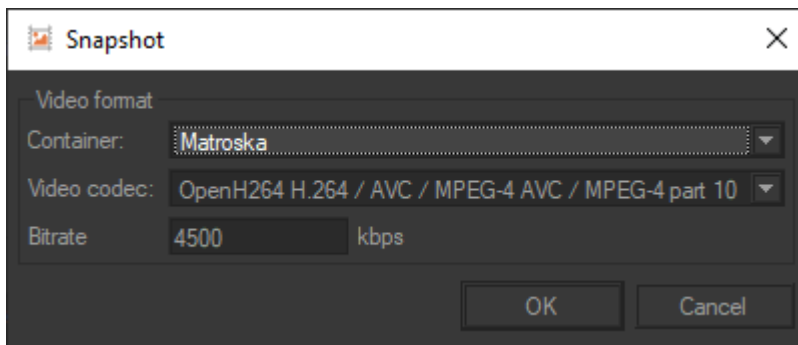

Video format settings.

The available **containers** (formats) are the following:

- AVI (Audio / Video Interleaved) ;
- MKV (Matroska Video) ;
- FLV (Flash Video).

Each video format can embed different encoding algorithms called codecs. Some of them are specific to a format. For example, only Sorenson codec is available for FLV format. Check the documentation of your movie processing software to know which format and codec best fit your needs.

The bitrate defines the amount of data stored to represent the frames. A low value will generate a small-sized file, but visual quality will be low. Conversely, a high value will generate a good quality video but the file will be larger.



Frame samples from videos generated using respectively a low bitrate (on the left) and a high bitrate (on the right).

Timeline Zone

The **Timeline Zone** provides the Timeline drop-down list from which you can choose the timeline to be rendered as a video.

Next to the timeline selection, specify the **frame rate** for the conversion from real-time animation to frame-based video.

Frame Output Zone

You have the option to render only a portion of the timeline range by providing the numbers of the desired frames:

- **Current Frame**,
- **All Frames**,
- A **Range** of frames.

It is also possible to indicate the initial number for the index appended to the filename of each frame in the Output Filename zone. By default, the value of this option is "0."

Preview

The **Preview** zone provides a preview of each of the frames that will be rendered.

You can move within the preview sequence:

- By using the buttons to step backwards (\leftarrow) and forwards (\rightarrow) one frame at a time in the sequence,
- By providing a frame number,
- By sliding the cursor along the bar.

You can also visualize the sequence by using the **Play** and **Stop** buttons. The frame sequence playback is displayed in the current active viewport.

Tick the **Loop** checkbox to play the video preview in a loop.



NOTE

The editors **Videos** and **Timelines** both use the active viewport to display playback. Consequently, you cannot view playback from both editors at the same time.

If the real-time playback in **Timelines** is playing, you will not be able to play the video preview. Use the controls in the **Timelines** to pause the real-time playback before playing the video preview.

Conversely, if video preview is playing, you must stop it in the **Videos** editor before starting real-time playback from **Timelines**.

Specific Settings for VR Objects

Available in: **Matter: Snapshot > Snapshot VR Object**

VR Objects produces a 3D image of the product. In this 3D image, the camera is stationary. The object is posed on a plane that turns at regular intervals of time. This allows you to view the object from every angle, with the ability to examine every detail.

Once the desired settings have been indicated, the **Render** button initiates the creation of the image files that constitute the VR object.



TIP

During rendering, a dialogue box is displayed to show the progression of the creation of the VR object files. At any time, you can pause the progression by clicking the **Pause** button, or cancel it by clicking on the **Cancel** button. If you have paused the rendering, start it again by clicking on **Resume**.

The **Viewer** button at the bottom of this dialogue box opens a frame viewing window.

Preview Frame Zone

The **Preview Frame** zone allows you to preview each frame of the camera's path around the object by moving the slider along the bar.

This preview allows you to check the point of observation. By default, the product is observed with a very large field of view. You can modify the point of observation at any time, either in the active viewport or with the tools in the **Camera Path [174]** zone. To apply a modification to the point of observation, click the **Acquire** button in the **Camera Path** zone.

Camera Path Zone

The **Camera Path Zone** defines the camera's position and its path.

To create a VR object, a series of images is generated, in which each image is taken from a point on a circle around a central point. **Center** values are used to position this central point relative to the origin of the coordinate system. The **Radius** value establishes the distance between the camera and this central point.

The value **FovY** in degrees provides the vertical field of view.

If you have made changes, click on the **Acquire** button in order to validate and apply these settings.

VR Object Settings

The VR object settings establish:

- The **Pan Range**: frames can be created either for a complete circle on a horizontal plane (the checkbox **Complete Loop** is ticked by default) or for a limited arc only. In this latter case, you must supply the angles between which your product will be observed.
- The **Tilt Range**: frames can be created to form a circle on a horizontal plane around the camera path's central point or to form a sphere or portion of a sphere around this same point. In these latter cases, you must supply the angles between which your product can be viewed. By default, the camera angles cover a full sphere. The viewing angles range from -90 degrees (the negative Y axis) to +90 degrees (the positive Y axis).
- The **Number of Frames**: frames can be created closer together or farther apart along the camera path. **Pan** provides the number of frames along the circle on the horizontal plane. **Tilt** provides the number of frames between the top and bottom angles, if you have defined a vertical plane.

Specific Settings for Cubic VR Panoramas

Available in: **Matter: Snapshot > Snapshot VR Panorama**

Cubic VR Panorama produces a 3D image of the product in a 3D space. It creates a cubic viewing space that gives the observer the impression to be in the product's 3D space.

Once the desired settings have been indicated, the **Render** button initiates the creation of the image files that constitute the cubic VR panorama.



TIP

During rendering, a dialogue box is displayed to show the progression of the creation of the video file. At any time, you can pause the progression by clicking the **Pause** button, or cancel it by clicking on the **Cancel** button. If you have paused the rendering, start it again by clicking on **Resume**.

The **Viewer** button at the bottom of this dialogue box opens a frame viewing window.

Configuration Keys (Editor)

Available in: **Matter: Timelines** > **Configuration Keys library** tab > double-click on a key name

Timelines > **Configuration** track > double-click on a key

Configuration Keys is an editor that allows you to set up and rename configuration keys used to change the configuration in an animation. The editor will open when you create a new configuration key or when you double-click on an existing key to modify it.

When creating or modifying a configuration key, the **Configuration Key** editor will open. Once open, it will always show the information for the current active key in the **Timelines** editor. To change the key shown in the editor, select a different key in the **Timelines** editor:

- Click on the name of a key in the **Configuration Key** library tab,
- Click on the representation of a configuration key in the Configuration track,
- Create a new configuration key using the button below the list of existing keys in the **Configuration Key** library tab. This will create a new key and activate it.

In the text zone at the top of the **Configuration Keys** editor, provide a name for the configuration key or change the key's current name. It is recommended that you give each key a different name.

In the **Configuration** zone, all of the configuration symbols are listed. Each symbol is paired with a drop-down menu of the possible values. Choose a value for each symbol.

You can choose to impose a new value for each of the symbols, or you can use the default value, **Keep previous** value, for certain symbols. As a general rule, it is best to impose a new value only for the symbol(s) that should be modified by the configuration key.

Choosing symbol values will determine the animation behavior when the playback reaches the activation point of the key in a timeline:

- If you set a new value, the configuration will be modified.
- If you leave the default **Keep previous** value for a symbol, the value of the symbol will not change during playback. Use **Keep previous** to create keys that can be used in multiple situations. This is particularly useful if you have configuration elements that are independent of one another.

Animation Sliders (Editor)

Available in: **Editors** > **Animation Sliders**

This editor allows you to test the effect of certain animations. It presents the different parts that can be animated by rotation or by translation, the animated meshes, and any animation clips that you have dragged and dropped from the libraries in the **Timelines** editor.

For existing translatable or rotatable parts to appear in this editor, the **Show in Animation Sliders** editor option must be checked for that part in the **Kinematics** sidebar tab in **Shaper**.

For each part, use the slider to manually animate the part. The animations are displayed in the active viewport. This allows you to view one animation in one viewport and another animation in a different viewport.

Animated Meshes

Using the slider for animated meshes allows you to move through the frames of the animation. The frame number is displayed to the right. You can also position the slider by typing a different frame number in this field.

Translations

The translation is limited by the distance set for the directional vector of the part. The value of the cursor position is displayed to the right and is expressed in the preferred units of measure for distances. You can also position the cursor by providing a new value in this field.

Rotations

The rotation is limited by the values set as min and max angles for the part. The value of the cursor position is displayed to the right and is expressed in degrees. You can also position the cursor by providing a new value in this field.

Clips

You can add clips that you want to manipulate in the **Animation Slider**. In **Matter**, from the libraries on the right of the **Timelines** editor, drag and drop clips you would like to manipulate onto the **Animation Slider** editor. This adds the clip to the editor. Clips are only visible in the editor while in the **Matter** module.

The slider allows you to scan through the clip. The value of the cursor position is displayed to the right and expressed in seconds. You can also position the cursor by providing a new value in this field.

Configurations (Editor)

Accessible in: **Matter** or **Shaper: Editors** > **Create Configurations**

The main tool of the [configuration system \[415\]](#) is the **Configurations** editor.

Configurations is an editor used to create configuration rules that establish the behavior of configurable layers for each product in your database. You can also associate rules together to create configurations or complex product variants.





Configurations is organized into tabs:

Rule Tab

Configuration rules are created in the **Rule** tab.

The **Rule** tab has two boxes. In the **Rules** box appears the list of rules already defined.

The following functions are available:

Icon	Function	Description
	New Simple Rule	This function opens the Simple Rules editor. In this dialog box, users create rules that have the following expression: (defined "symbol"). Simple rule creation is detailed in the section Creating Simple Rules [420] .
	New Complex Rule	This function is for creating a rule with the Complex Rules editor. Complex rules involve the function "defined" as well as the logical operators "and", "or", "not" and "xor". Complex rule creation is described in the section Creating Complex Rules [426] . Information on complex rule syntax can be found in the chapter Rule Syntax [428] .
	Replace String	This function is for replacing the name of a symbol with a new string of text. It is particularly helpful for changing the prefixes ("partition.") of several " partition.value_n " symbols simultaneously. The name of the symbol will be replaced simultaneously in all of the rules where it is used, as well as in the Configuration Browser .
	Delete Rule	This function is for deleting the rule selected in the list.

Rule expressions are entered directly inside the **Expression** box. The **Insert Tool** is for inserting a string corresponding to a simple rule for a defined symbol.

The **Compiler Output** box allows for checking rule syntax. If syntax problems are detected during rule validation, an error message is displayed in this box.

The second box in the **Rule** tab shows the properties of the selected rule.

It includes the **Rule** field which allows the selected rule in the list to be renamed.

 **Edit Rule Expression** opens the **Complex Rules** editor for modifying rule expressions directly.

The **Targets** box indicates the target layer(s) of the selected rule.

When a geometry, aspect, position, overlay, or environment layer is defined as a target for a configuration rule, the icon  is displayed next to that layer in the corresponding layer editor. Clicking on this icon selects the rule in the **Configurations** editor.

Browser Tab





This tab is the **Configuration Browser**. It can also be accessed from **Editors > Configuration Browser**.

The **Configuration Browser** is for testing and exploring product derivatives. The Configuration Browser interface is updated automatically according to the [configuration rules \[418\]](#) created: all symbols used in the rules of the active product are gathered and displayed in it. The browser lists all available symbols for the product displayed in the active viewport.

The browser allows you to select which symbols among those available should be defined for rule evaluation. The selection is made either with checkboxes or from drop-down lists. All product derivatives may thus be explored.

Library Tab



The **Library** is for managing and editing configuration sets, that is, a set of defined symbols and groupings identified in the **Configuration Browser**. It includes the following functions:

Icon	Function	Description
	New Configuration	Creates a configuration.
	Store Configuration	Saves changes made to an existing configuration. The current set of defined symbols is saved, replacing the previous set of defined symbols.
	Restore Configuration	Deletes the configuration selected in the list.
	Delete Configuration	Deletes the configuration selected in the list.

The second box includes a field for renaming configurations.



Edit Configuration opens the **Symbol Sets** editor. This editor lists all available and defined symbols. In the **Available Symbols** list, defined symbols are grayed-out.

Icon	Function	Description
	Define Symbol	Adds the symbol selected in the Available Symbols list to the Defined Symbols list.
	Delete Defined Symbol	Deletes the selected symbol from the Defined Symbols list.

Inspection Tab

In the **Rules Value** box, the list of existing rules is displayed. Rules evaluated as true with the current defined symbols are highlighted in green, and highlighted in red otherwise. The expression of the rule selected is displayed in the **Rule Evaluation Trace** box. The parts of the rule's expression displayed in green are true and the parts displayed in red are false. This tool allows for quick determination of the reason why a rule is evaluated as false.

GPU Consumption (Editor)

Available in: **Shaper** or **Matter: Editors > Advanced > GPU Consumption**

In order to render the content of a database, Patchwork 3D consumes GPU resources. The elements to be rendered are stored in the graphics card. The amount of resources required varies depending on the complexity, size and level of detail of the item to be rendered, while the total amount of resources available depends on the graphics card used.

The analysis tools provided in **GPU Consumption** help to find anomalies or user practices that contribute to an overconsumption of GPU resources.

Running an Analysis

Before moving forward, you run an analysis of the GPU resources that are used.



TIP

This analysis must be run from **Matter**.

1. Choose what you would like to analyze from the drop-down menu. The analysis can be limited to what is currently displayed in the active viewport, or it can reflect all of the products, along with their configurations, that are part of your database. An analysis of the current viewport will take less time to run than an analysis of the full database.
2. Start the analysis by clicking on . This may take some time.

Once the analysis has finished, you have access to the two tabs that provide two different overviews of the results: the **summary** of consumption and the **detection** of overconsumption.

Summary of Consumption

The **Summary** tab provides a global overview of the GPU consumption.

The consumption is organized by tab based on the type of Patchwork 3D resource. The label for each table shows the type of Patchwork 3D resource, followed by the total consumption for this type of resource. The unused Patchwork 3D resources that are still present in the database are not taken into account in the total consumption.

The following categories of resources are analyzed:

Type of resource	Definition	Additional information provided
Textures	Images and videos used as textures, including backgrounds	Resolution in pixels, color profile format
Lightmaps		Resolution in pixels, lightmap format
Bumpmaps	Textures used as bumpmaps	Resolution in pixels
Environments		Resolution in pixels
Meshes		Number of vertices, number of triangles

The summary presents the analysis results as a table:

- **Resource**: the name of the Patchwork 3D resource,



TIP

Environments created by Patchwork 3D to display specular reflections are listed under the name "Cube map."

- **Size:** amount of GPU memory allocated,
- **Information,**
- **Activation:** This column is only present for textures and bumpmaps. A comment is displayed if the resource is **inactive**. A texture will be classified as inactive, for example, if it is used as a **Color map** in a material applied to a surface in the active viewport but for which the checkbox enabling use of a color map is not checked in the **Materials** editor.

Several operations to manage this information are available:

- Click on a column header to sort by that column.
- Double-click on an item to expand the list of elements using this resource.
- Right-click, then choose **Activate** to select the element in the interface.



TIP

The **Show only selected surfaces** mode displays only the elements concerned by an operation. In **Shaper**, activate the mode Show only selected surfaces with the **S** key. When you choose the option **Activate** for a group of surfaces, they are displayed. The rest of the model is hidden. In **Matter**, when the **Activate** option opens the **Materials** editor, use the



Only show active material button to display only the surfaces using this material.

A total consumption of GPU resources is indicated at the bottom of the editor. This total is the sum of the subtotals listed for each resource tab. The total consumption corresponds to the analyzed context only: if the analysis covers only the current viewport, other viewports are ignored. If the analysis covers all products in the database, other databases that might be open in another instance of Patchwork 3D and other sources of GPU consumption are not included.



From this tab you can **Export** the summary in CSV format.



NOTE

The GPU memory consumption gauge, which is available in the render statistics, shows total GPU consumption, including consumption sources external to Patchwork 3D. By contrast, the summary of consumption only shows elements created directly or indirectly by a user in Patchwork 3D. Consequently, slight differences may exist between the totals reported by the two tools. See [Render Statistics \[95\]](#).



NOTE

The GPU resource purge wipes the resources used for inactive viewports from the graphics card. This operation has no impact on the summary of consumption, which provides information regarding either the active viewport or all products in the database, regardless of their presence or absence in a viewport. For more information on this function, see [Purging Unused GPU Resources \[99\]](#).

Detection of Overconsumption

The **Detection** tab offers customizable detection rules that can be used to find the elements that use significantly more resources than others without contributing to an improved overall rendering.

Rules

Each rule is based on a limit that can be set based on your requirements. The limits that you indicate are saved by Patchwork 3D and will be available in all databases that you open on the same computer.

The default values are given for demonstration purposes only and may not be appropriate for your usage of Patchwork 3D.

The following rules are available:

- Size of the texture in pixels,
- Number of layers in a multilayer material,
- Number of triangles in a surface,
- Average area of a triangle for a surface in mm².

Check the boxes next to the rules you would like to use in your detection.

Verify the value of the limits. If necessary, modify them by typing a new value directly in the field, by clicking on the field and using the up and down arrows on the keyboard, or by clicking on the arrows beside the field.

Obtain the results by clicking on one of the buttons at the bottom right of the editor.

Colored Display



displays the results of the detection in the viewport by coloring each surface.

Color	Magnitude of noncompliance
Gray	This surface was not included in the analysis that was run.
Green	No over-consumption was detected for this surface.
Yellow	This surface exceeds a detection rule by up to 50%.
Orange	This surface exceeds a detection rule by 50-100%.
Red	This surface exceeds a detection rule by 100% or more.

When the false color mode is activated, the view is surrounded by a white frame. To exit this display mode:

- Press the **Esc** key.

- Click the button again .

List of Results for All Surfaces



opens a window containing the diagnostic results for all surfaces. The results are presented in the same format as the statement. However, only cases where the threshold is exceeded are listed.

The color of each line indicates the magnitude of noncompliance with the provided rule limits:

Color	Magnitude of noncompliance
Yellow	Between 100% and 150% of the limit
Orange	Between 150% and 200% of the limit
Red	Greater than 200% of the limit

Various operations allow you to manage the results of the detection:

- Sort: Click on the column header to sort the list.
- Find an element: Right-click on an entry, then choose **Activate** to find the element in the interface.

Close this window by clicking **OK**.

Results for a Picked Surface



allows you to pick a specific surface to analyze. The cursor will change to an eyedropper.

Click on the desired surface in the viewport. A new window will open.

This window contains the detection results for the selected surface only. The results are presented in the same format as the summary. However, only the cases exceeding the rules' limits are listed.

The color of each line indicates the magnitude of noncompliance with the provided rule limits:

Color	Magnitude of noncompliance
Yellow	Between 100% and 150% of the limit
Orange	Between 150% and 200% of the limit
Red	Greater than 200% of the limit

Various operations allow you to manage the results of the detection:

- Sort: Click on the column header to sort the list.
- Find an element: Right-click on an entry, then choose **Activate** to find the element in the interface.

Close this window by clicking **OK**.

Product Environments (Editor)

Available in: **Matter: Editors** >  **Product Environments**



 **Product Environments** provides the tools to prepare your environments for displaying your products. It also manages environment layers. Environment layers allow for the creation of several product variants with different environments. These layers can then be used in the configuration system.

Environment Layers Tab





Environment layers are created in the **Environment Layers** tab.

The name of the product in the active viewport is displayed at the top of this tab. The rest of the tab is composed of the **Environment Layers**, **Environments**, and **Surfaces using environment** boxes.

Environment Layers Box

This box contains a list of the existing environment layers. Each layer has a toggle button to activate or deactivate its visibility. The symbol  means that the layer is visible. When a layer is hidden, this symbol is barred. The  icon is used to pinpoint the active layer, which will receive all the new environment allocations.

The following operations can be performed on the environment layers:

Icon	Function	Description
	New Environment Layer	A new environment layer is created and added to the list of existing layers.
	Duplicate Environment Layer	Creates a copy of the selected environment layer. The mention "Copy" is added to the name of the created layer.
	Rename Environment Layer	This operation opens a dialog box which allows the selected layer to be renamed.
	Solo Environment Layer	This operation displays the surfaces affected by an environment contained in the selected layer only.
	Delete Environment Layer	The selected environment layer is deleted. The minimum number of environment layers is one.

When the **Product Environments** editor is opened, it already contains a layer called Default. When opening a database created with a version of Patchwork 3D prior to version 5.5, the environments assigned to the product are automatically imported in this layer.



NOTE

When no environment layer is selected, the name of the default environment is displayed in the **Environments** box. When all environment layers are hidden, the default environment is used.

As with aspect and position layers, the position of environment layers in the layer list is taken into account when displaying environments on the product. The layer hierarchy is assessed from the top to the bottom of the list:





- The first allocation of a global environment found in a layer is displayed in the product.
- If, for a given surface, any environments are specifically assigned, the highest-ranking of these environments is applied, even if a higher-ranking global environment is defined.

Environments Box

This box displays the list of environments contained in the selected layer of the **Environment layers** box. A global and several surface-specific environments can be present in the same layer.

Selecting an environment in this box displays the list of Surfaces affected by this environment in the **Surfaces using environment** box.

The following actions can be performed on a selected environment:

Icon	Function	Description
	Solo Environment	Restricts the rendering to the surfaces affected by the environment selected in the list.
	Set Active Environment	Defines the selected environment as the one considered active in the Matter sidebar's environment library.
	Find Environment	Selects the corresponding environment in the Matter sidebar's environment library.
	Remove Environment	Removes the assignment of the selected environment from the surfaces using it in the current layer.

To set an environment as a global environment in the active layer, drag and drop it onto the product.

To assign a local environment, drag and drop it onto the targeted surfaces by holding down **Shift** key and by selecting **Apply To Surface** in the opening context menu.



To replace an environment in the active layer, drag and drop the desired environment from the Matter sidebar's environment library onto the name of the environment to be replaced in the list of the **Environments** box. It is also possible to drag and drop the desired environment onto a selection of surfaces in the **Surfaces using environment** box to assign it to the selection.

Surfaces Using Environment Box

This box lists the surfaces affected by the environment selected in the **Environments** box.

The following actions can be performed on the selected environment(s):

Icon	Function	Description
	Solo Surfaces	Restricts rendering to the selected surfaces.

Icon	Function	Description
	<i>Reset Orientation</i>	Resets the orientation of the environment affecting the selected surfaces. This feature applies only to surfaces for which the environment has been specifically reoriented. These surfaces are tagged with the icon  .
	<i>Remove Environment</i>	Removes the assignment of the environment specific to the selected surfaces.

Surface names displayed in italics and crossed out correspond to surfaces which possess an unused environment allocation. For a global environment allocation this occurs either when another global environment allocation is listed higher in the layer hierarchy, or when a surface-specific environment exists. For a surface-specific environment, this occurs when another surface-specific environment allocation is listed higher in the layer hierarchy.

Product Environment Properties Tab

The ***Product Environment Properties*** tab presents the functions used to prepare environments by adjusting their orientation or by defining the specific settings for the use of a real-time sun.



It contains four boxes: ***Environments***, ***Orientation***, ***Real-Time Sun*** and ***Environment's Brightest Point***.

Environments Box

This box lists the environments that are globally allocated in the product or specifically allocated to certain product surfaces. Selecting an environment from this list gives access to its orientation settings, to the real-time sun settings, and to the settings for the definition of its brightest point. The settings for the selected environment are modifiable when the environment is the product's active environment. Otherwise, they are visible as read-only.

Orientation Box

The ***Orientation*** box is designed to modify the two following types of orientation:

- Environment orientation in the product. This orientation can also be modified by activating the ***Environment Orientation*** mode  and moving the environment directly using the mouse. The global orientation of the visible environment under the mouse is modified, even when the environment is a surface-specific environment affected to multiple surfaces.
- Surface-specific orientation, typically used to reorient reflections on a given surface. This operation is also performed by activating the ***Environment Orientation*** mode  and moving the environment by using the mouse to click and drag while holding the ***Shift*** key, or from the ***Surface Properties***.

This orientation feature does not impact the environment's default orientation stored in the environment properties, which is used for initializing the environment orientation in the product upon allocation.

In order to change the selected environment's orientation from the ***Environments*** box, enter the desired value for the orientation with regard to the ***X***, ***Y***, and ***Z*** axis in the corresponding fields.

You can reload the default orientation at any time by clicking the **Use default orientation** button.

In order to save an environment orientation as the default, click on the **Set as default orientation** button.

Real-Time Sun Box

The settings in this box are used to adjust the real-time sun specific to the selected environment.

Parameters defined in the editor **Real-time sun** can be ignored in favor of the parameters defined specifically for the selected environment by checking the box **Use the following sun settings when using this environment** . These correspond to those in the box **Sun setting** from the editor **Real-time sun** .

If no real-time sun is active for the product as a whole, it is still possible to use a specific real-time sun in an environment by ticking the checkboxes **Apply the following sun settings when using this environment** and **On**.

Environment's Brightest Point Box

This box is used to specify the brightest point of an environment in order to position the real-time sun with the help of the positioning option **Extracted from Environment**. This can be set up either manually or by an automatically search.

To run the automatic identification of the position of the brightest point in the environment, select the environment in the **Environments** box, then click **Find automatically**. The brightest point of the current environment is then identified by a square on the displayed environment.

It is also possible to click directly on the displayed environment to pinpoint the desired direction of the real-time sun.

The sun remains fixed relative to the environment when the environment **Orientation** feature is used.

Tag Manager



Available in: **Shaper: Surface > Tag Manager (Ctrl+M)**

The **Tag Manager** uses buttons to manage the list of tags, to create tags, to add tags to a selection, and to manage a selection using tags.



Tags are used in **Shaper** and in **Matter** to manage the selection and to:

- mark and track surfaces to be finished later [277],
- apply a material to several surfaces at the same time [364],
- exclude surfaces from a local environment [218],
- indicate the surface that are not affected by clipping planes [208],
- indicate the surfaces that function as configuration triggers in Live Mode [456].



Managing the list of displayed tags:

Icon	Function
	Remove all tags from the display list. This does not delete the tags.
	Recover the tags from all surfaces and display them in the list.
	Recover only the tags from the selected surfaces and add them to the list.



Creating tags:

Icon	Function
	Add the edited tag to the selection.
	Create a tag with the name in the text box and add it to the list.

Applying or removing tags from a selection:

Icon	Function
	Delete the tag highlighted in the list from the selected surfaces.
	Add the tag highlighted in the list to the selected surfaces.

Managing the selection:

Icon	Function
	Select the surfaces using the tag highlighted in the list.
	When some surfaces are already selected, add the surface using this tag to the selection.
	When some surface are already selected, deselect only the surfaces using this tag.

Using Tags to Create Configuration Triggers

Tags can be used to create configuration triggers for the **Live Mode**.

When a properly tagged surface is clicked during **Live Mode**, the next configuration value is displayed. If the configuration property is displayed in the Configuration Browser as a check-box, successive clicks will enable and disable the option. If the configuration property contains a set of values, such as a series of colors, successive clicks will cycle through the colors one by one.

To do so, you will need to create specific tags for the surfaces that will act as triggers. The tag must correspond to the partition of the configuration that you want to cycle through. To add rules associated

with the partition type, use the tag partition. To add rules associated with the partition.value type, use the tag partition.

Examples:

Type	Configuration symbol	Tag to apply	Result
partition	armrest	armrest	show/hides an armrest
partition.value	material.wood	material	shows the different values (wood, marble...) one after the other
partition.value	material.marble	material	shows the different values (wood, marble...) one after the other

You may be interested in the following topics:

- [Product configurations \[415\]](#)
- [Live Mode \[456\]](#)

Gradients (Editor)

Available in: **Matter: Editors > Materials** >  in the **Gradient** zone

The editor **Materials** gives access to **Gradients**, an editor that allows you to create your own gradients or to modify pre-existing gradients in Patchwork 3D. These gradients are used to display a different color depending on the angle at which a surface is viewed.

This parameter is available for the following types of material:

- Standard Material: **Diffuse** and **Diffuse and Reflection** types,
- Multilayer material: **Diffuse, Illumination** and **Flakes**,
- Stickers using the same types or layers as above.



You will find the same configuration of operations in the **Gradients** editor, namely operations to **Create**, **Import**, **Save**, or **Delete** a gradient, as in the other types of editor.



NOTE

The new gradient created appears in the **Gradient** palette and is named by default **gradient 0**, **gradient 1**, etc. You can rename it directly in the input field relating thereto.

Icon	Function	Description
	Delete	Delete a gradient from the palette



Icon	Function	Description
	Import	Load a gradient. The imported gradient is saved in the Gradients directory by default.
	Save	Save a gradient. The modifications are saved in the Gradients directory by default.

- In the **Gradient** zone, slide one of the two squares under the **Gradient** banner head to modify the gradient, or enter a value directly in the **Angle** field.
- Modify the color using the **Color Chooser**, accessible by clicking on the **Color** square.



TIP

To open the **Color Chooser**, click on one of the two squares of the **Gradient** banner head. The gradient created is displayed in the banner head. For more information on modifying colors, see [Color Chooser \[231\]](#).

Icon	Function	Description
	Create a new gradient	Create your gradient directly using the Color Chooser , then click this button.
	Assign	To assign a new gradient to an element in the palette, select the gradient you want to assign the new colors to, then click this button.

To modify a gradient of the **Gradient Palette**, select it and double-click on it. The gradient is displayed in the viewer.

The **Position as Ramp Access Angle** parameter allows you to specify a gradient angle.

Importing Gradient Ramps in .csv Format

Gradient ramp files in CSV format are supported.

With the **Import gradient**  button, you can import KGR gradient files generated by the **Gradients** editor, or CSV gradient files.

- Select the gradient file in KGR or CSV format that you would like to import from your workstation.
- Click on **Open** to validate.

The imported gradient is added to the gradient palette.

For a CSV file, the name of the CSV file is used as the name of the new gradient.

Valid .csv files begin with a header line, followed by lines listing the gradient angle and the colors to apply at that angle. The colors are expressed in one of the following encodings:

- [RGB \[190\]](#)
- [CIE Lab Profile \[190\]](#)

The values contained in each line must be separated by a comma (,); if the line contains decimal numbers, they must use a point (.) as the decimal separator.

Parameter	Accepted Values
Header as first line	Required
Value separator	,
Decimal separator	.
End of line	No special character

If the file structure is not respected, the importer will stop. The error message that is show will indicate the line in your file where the first structural error was found.

RGB Profile

Parameter	Accepted Values
Required header line	angle,R,G,B
Angle	Whole numbers from 0 to 90 inclusive
R	Whole numbers from 0 to 255 inclusive
G	Whole numbers from 0 to 255 inclusive
B	Whole numbers from 0 to 255 inclusive

If the accepted values are not respected, the importer will replace any value that is out of range with the minimum or maximum accepted value, whichever is closer. For example, an angle value of 100 degrees will be replaced by the maximum accepted value, that is, 90.

Example

angle,R,G,B 0,255,255,255 1,255,255,255 2,255,255,255 3,255,255,255 ... 90,255,204,0

CIE Lab Profile

Parameter	Accepted Values
Required header line	angle,L,a,b
Angle	Whole numbers from 0 to 90 inclusive
L	Decimals from -128.0 to 128.0 inclusive
a	Decimals from 0.0 to 100.0 inclusive
b	Decimals from 0.0 to 100.0 inclusive

If the accepted values are not respected, the importer will replace any value that is out of range with the minimum or maximum accepted value, whichever is closer. For example, a L value of -130 will be replaced by the minimum accepted value, that is, -128.

Example

angle,L,a,b 0,100.0,0.0,0.0 1,100.0,0.0,-0.000001 2,100.0,0.0,-0.000001 3,100.0,0.0,-0.000001 ...
90,88.122,1.933,50.797

Flakes Color Editor







Available in: **Matter**:

- **Materials** (Editor) in **Layers** tab of a multilayer material,
- Right click on a multilayer material: **Material** > **Edit material: [your material]** in the **Layers** tab of the material.



The Flakes Color Editor interface is composed of two functional zones:

- the **Color Palettes** box that lists the available color palettes,
- the **Palettes Editor** box that allows you to create color palettes.



The **Color palettes** box gathers the following operations:

Icon	Description
	Saves a color palette
	Updates the selected palette of color.
	<p>TIP</p> <p>This feature is useful for updating the color palette with colors you just added.</p>
	Imports one or more color palettes in CSV format.
	Exports the selected color palette in CSV format.
	Deletes the selected color palette.

The **Palettes Editor** box contains the following operations:

Icon	Description
	Adds one color to the selected color palette.
	Deletes selected color of the palette.

How to create a color palette?

1. In the Palette Editor of flakes, click on the color area to choose the color you want to assign at the palette.
2. If necessary, click on this icon  to add one or more color. Click this  to delete a color.
3. Click then on this icon  to add a color palette to the list of palettes.
4. Repeat steps 1 to 3 to add as many color palettes as you want to the list.

How to import a color palette in CSV format?

The process of importing a color palette in CSV format works as the same as the gradients editor. Please refer to the following chapter [Importing Gradient Ramps in .csv Format \[189\]](#) for more information.

Rendered Views History

Available in: **Matter: Editors** >  **Rendered Views History**

The **Rendered Views History** is a tool available to compare several views of products in Patchwork 3D. It saves rendered views, displays them as miniature images, and restores their original size. It shows views taken of any of the products in a database.

The views are saved as soon as they are added to the **Rendered Views History**.

To select a view in the **Rendered Views History**, click on the corresponding miniature. Several views can be selected at once.

- By holding down the **Shift** key (for a continuous selection) or the **Ctrl** key (for a discontinuous selection).
- By holding down the left mouse button and drawing a rectangle over the desired views.







NOTE

The **Rendered Views History** in Patchwork 3D also loads the views rendered with the **Raytracing** editor from versions 5.2 to 5.4.

Operations Toolbar

This toolbar located at the bottom of the **Rendered Views History** provides the tools to manage the views in the history.

Icon	Function	Description
	Add rendered view	Saves the view in the active viewport to the history.
	Export views	Allows the selected views to be exported by saving each view as a separate image file. When this button is clicked, it opens the Export images dialogue box.
	Reload view bookmark	Repositions the camera in the active viewport to the position that was used to create the selected view.
	Rename rendered view	Allows the view to be renamed. Each view must have a unique name. If the user enters a name that has already been assigned to another view in the history, the Rename rendered view function will add a number to the end of the duplicate name: Product (1) .
	Delete selected views	Deletes the selected views.

The **Export** images dialogue box shows a list of the selected views, the choice of the directory where the files will be saved, and the choice of file format to be generated.

Some of these operations are available in the context menu that is accessed by right-clicking on a view. The actions chosen from the context menu affect only one view at a time.

From the context menu, you can **Export view**, **Reload view bookmark**, **Rename** view or **Delete** view.

Engines Used for Rendering

The view image is rendered by the engine used to calculate it in the active viewport. If any part of the active view is calculated by raytracing, the image will be rendered by the raytracing engine. However, if the view is calculated by the OpenGL engine, the image will be rendered by this engine.

The engine used to render the view (OpenGL or Raytracing) is indicated on the upper part of the thumbnail.

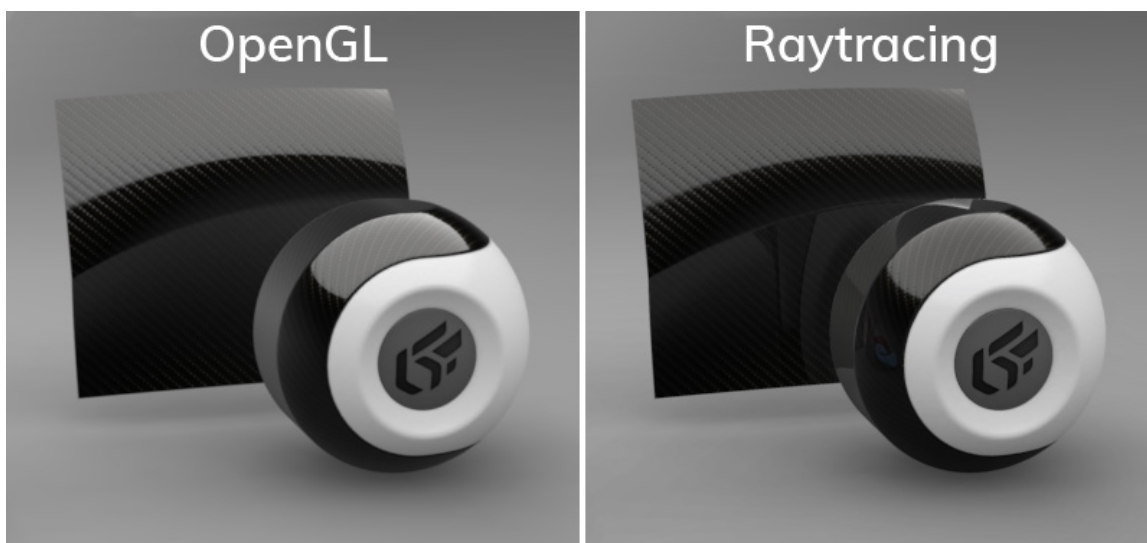

Indication of rendering engine on thumbnails (OpenGL engine on the left; raytracing engine on the right).



NOTE

The raytracing engine can be set up to automatically add views rendered by raytracing to the **Rendered Views History**.



Click on the button **Raytracing settings** on the toolbar **Editors** or navigate in **Editors > Raytracing settings**. An option in the **Viewport Raytracing** box allows the **Automatically add to Rendered Views History on render** option to be activated or deactivated. This option is disabled by default.

Recalling a View

Double-clicking on a view will recall it in the active viewport. The size of the original image is restored and the viewport is resized accordingly.

Text Image (Editor)

Available in: **Matter: Textures Library** (right-hand sidebar) > **Edit** or **Create a new text texture**

The **Text Image** editor creates, based on a provided text, an image that can be used as a texture. This text texture can be used in all of the same contexts as a standard texture.

The interface is divided into four zones:

- Operations toolbar and name of the active text image: shortcuts to the operations of the texture library.
- Settings for **Geometry**, **Colors**, and **Font**: management of the look of the text to be displayed.
- **Text**: input field for the text to be displayed.
- **Preview**: full-size preview of the text to be displayed.

Operations Toolbar

The following operations are available from the operations bar:

Icon	Description
	Drag-and-drop start point for assigning the texture to the appropriate field in a material, an overlay...
	Create a new text texture.
	Duplicate the current text texture.

You can also rename this texture by modifying the name in this zone and saving your changes by pressing **Enter**.

Display Settings

Geometry Settings	Description
Size	Dimensions of the image text box in which the text will appear, in pixels.
Anchor	Placement of the upper left-hand corner of the text with regard to the upper left-hand corner of the text box in which the text appears.
Color Settings	Description
Background	Color and level of opacity of the image background. Opacity is given as a value between 0 (fully transparent) and 1 (fully opaque).
Font	Color and level of opacity of the text. Opacity is given as a value between 0 (fully transparent) and 1 (fully opaque).
Font Settings	Description
Font	Drop-down menu offering a choice of fonts from among the fonts installed on the current computer.
<div style="background-color: #f0e6e6; padding: 10px; border: 1px solid #ccc;"> <p> WARNING Fonts used in text images are not embedded in the database. If this database will be handled on another machine, make sure that the chosen fonts are also installed on the other machine.</p> <p>The texture created by this editor will remain usable as-is on any machine, regardless of the availability of the original fonts, until it is modified.</p> </div>	
Style	Drop-down menu offering the choice of styles available for the chosen font. Common styles include bold or italics.
Size	Size of the font's characters in points (pt).

Text

Insert your **Text** in the Text zone.

Supported text includes all characters rendered in the UTF-8 encoding, as long as these characters can be displayed in the selected font.

Text is displayed with no styling. Text wrapping is not applied, but new lines inserted manually are taken into account.

No character limit is imposed, but only the text that fits in the image text box will be displayed. This is determined by the size of the text box as set in the geometry settings as well as by the font size provided.

Preview

The  button updates the text preview, which is displayed in full-size. This action also saves the current settings.

The  button undoes any modifications to the settings that have been applied after the last save and update of the preview. The display settings are reset to the state displayed in the preview zone.

Materials (Editor)







Available in: **Matter: Editors > Materials (F5)**

Materials  is an editor that provides access to the parameters of the active material.

The interface is organized into two functional zones:

- Operations bar and material name.
- Settings for a given type of material, usually organized in tabs, followed by global options applied to all tabs. You can find more information on the options specific to each type of material in the corresponding sections.

The operations bar provides access to basic material operations:

Icon	Function	Description
	Drag-and-drop start point	Drag the material being edited from this point and drop it on a surface in a 3D viewport to assign it.
	Selection eyedropper	Select the eyedropper, then click on a material assigned to a surface in a 3D viewport. This will make the selected material active and allows it to be edited.
	Solo Material	The Solo Material mode hides all surfaces except the ones to which the current material is assigned. This visualization mode applies in all of the open viewports. This button both enables and disables the Solo Material mode.
	Select all the surfaces	Click on this button to select in Shaper all the surfaces that have the same material.
	Create a new material	Click on this button to open the window to choose a type of material. When you validate your choice, a new material of that type will be created.
	Duplicate the material	Click on this button to duplicate the active material whose settings are shown in the editor. The new material is made active when it is created.

Icon	Function	Description
	Convert to multilayer material	Convert the selected material(s) into equivalent multilayer materials.
Text field	Name of the material	The text field shows the name of the active material. To change it, click within the text field and use the Enter key to validate your changes once you have finished.

The specific settings for each material class make up the rest of this editor. They are described in the chapter [Materials \[323\]](#).

Live Mode (Editor)

Accessible in: **Matter: Editors** >  **Live mode**

Live Mode is an editor that associates a chosen surface with one or more chosen animations. These associations are then used in **Live** mode, a navigation mode in which clicking on designated surfaces or pressing preset keys triggers animations.

Defining Triggers

The editor that sets up **Live** mode is composed of two main sections: the list of animations associated with a trigger, followed by the operations toolbar where the buttons are located.

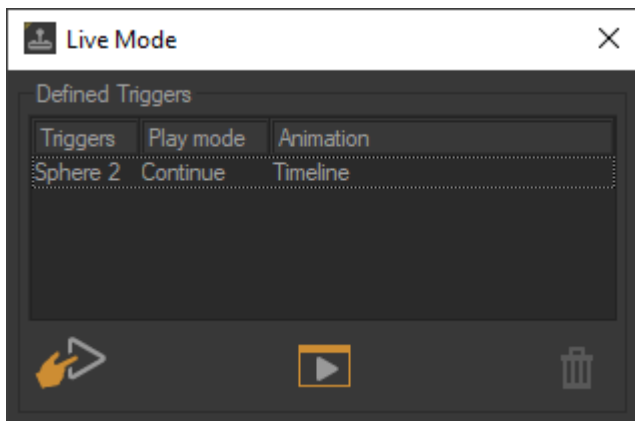

Live Mode Editor

The list of triggers contains all of the animations with a trigger. For each animation, the following information is displayed:

Title	Information
Trigger	The name of the surface or Shaper object that acts as a trigger when clicked to start the animation.
Play Mode	The name of the playback mode. This mode defines what happens when a trigger is clicked again after the playback of an animation has been started.

Title	Information
Animation	The name of the channel clip or the timeline that will be played.

This list can be sorted. Click on the column header by which you want to sort the list.



TIP

You can double click on a trigger in the list to edit it.

The operations toolbar contains the following buttons:

Icon	Function
	Add a trigger.
	Switch to Live mode in the main window. To exit the Live Mode, click the button in the main toolbar of Matter .
	Delete the selected triggered animation. This disassociates the trigger and the clip or timeline, and removes the animation from the list in this editor. The clip or timeline is not deleted from the database.

Creating a new triggered animation requires two steps: creating a trigger, then associating it with a clip or a timeline.



TIP

You must have created at least one clip or timeline in the **Timelines** editor.

Creating a Trigger

Use the button to add a trigger. Two types of trigger are available:

Type	Function
Mouse	This type of trigger plays a clip or a timeline when you click on a specific surface in the scene.
Keyboard	This type of trigger plays a clip or a timeline when you press a specific key on the keyboard.

1. First, select the type of trigger.
2. For a mouse trigger, select the surface, or kinematics node. You can do so using the list or by clicking on the button to use an eyedropper to pick a surface, a null, a vector or a rotation axis. When using a null, a vector, or a rotation axis, all of its child surfaces will function as triggers.

- For a keyboard trigger, click on the button to record the keystroke that will function as a trigger.

Associating a Clip or a Timeline

Once the trigger has been saved, a window opens.

- Select the clip or timeline to associate with the trigger.



TIP

A single trigger can trigger multiple clips or activate multiple keys. Each action taken will be listed separately. Multiple selection of clips or keys with keys **Shift** or **Ctrl** is possible ; this allows multiple lines to be created simultaneously with the same trigger.

- Validate with the button **OK** or click on the button **Cancel** to close this window without saving an association.

Choosing a Play Mode

- Choose one of the four modes from the **Play Mode** drop-down list. This mode defines the behavior of the playback if the trigger is clicked again while the animation is playing.

Mode	Description
Continue	Click on the trigger for a playing animation to pause it. Click on the trigger for a paused animation to resume playback from where it left off.
Reset	Click on the trigger for a playing animation to restart it from the beginning.
Reverse with pause	Click on the trigger for a playing animation to pause it. Click on the trigger for a paused animation to resume playback from where it left off, playing the animation backwards.
Reverse without pause	Click on the trigger for a playing animation to reverse the direction of playback: the animation will play backward from the current point.



TIP

If you do not choose a mode, the **Continue** mode is used by default.

- Click **OK** to save this triggered animation or click **Cancel** to close this window without saving.

Configuration Browser

Available in: **Matter** or **Shaper: Editors** > **Configuration Browser**

The **Configuration Browser** is for testing and exploring product derivatives. The Configuration Browser interface is updated automatically according to the [configuration rules \[418\]](#) created: all symbols used in rules pertaining to the active product are gathered and displayed in it. The browser lists all available symbols for the product displayed in the active viewport.

The browser allows you to select which symbols among those available should be defined for rule evaluation. The selection is made either with checkboxes or from drop-down lists. All product derivatives may thus be explored.

In **Shaper**, the **Configuration browser** displays only the parameters of the geometry, illumination, and position layers. Aspect and environment layers that have no application in **Shaper**, the associated parameters are hidden. If rules based on appearance, overlay, or environment layers have been configured for your product, you will find the associated parameters as soon as you return to the interface **Matter**.

In **Shaper** and **Matter**, the **Configuration Browser** displays the configured **Cameras** in the Camera editor.

Measuring Tool

Available in: **Shaper** or **Matter: Editors > Advanced > Measuring tool**>

The Measuring Tool shows the distance between two points that you have chosen. This distance between these two points may thus be represented visually in the active view.



TIP

The **Show the gizmos** option must be checked to use the eyedroppers.

- Click on the green eyedropper and select your starting point in the viewing window.
- Click on the yellow eyedropper and designate the end point in the scene.

The result is displayed in the **Distance** field of the **Measure** zone at the bottom of the editor.



TIP

The distance is represented visually.

The **Enable Depth Test** function allows you to show the gizmos measuring the distance between measuring points in the scene without them being obscured by surfaces. Uncheck this parameter to display the points and the measurement above all the surfaces.

Snapshot Batcher

Available in: **Matter: Snapshot** >  **Snapshot Batcher**

The **Snapshot Batcher** is used to delay the rendering of a list of snapshots. It improves the fluidity of the workflow by allowing a user to batch snapshots in order to launch the rendering operations at a more convenient time.

Snapshots batched for delayed rendering are automatically saved when the database is saved.

Snapshots Box

The box **Snapshots** contains the list of all the captures awaiting rendering. It is fed from the various capture editors (**Snapshot Image**, **Snapshot Video**, **Snapshot VR object**, or **Snapshot Cubic VR Panorama**).



TIP

The list of captures is associated with the active viewport. When the active viewport is changed, the snapshots corresponding to that viewport or product are no longer shown, though they remain in memory. Reactivate the original viewport to recover the corresponding snapshots.

The **Snapshots** box contains a list organized into four columns. Each row of the list represents a snapshot.

- The selection column shows an icon of a checked box when the snapshot is selected. Selected snapshots will be rendered by the batcher when the rendering is launched.
- The **Name** column shows the name of the snapshot. This name is either provided by the user or automatically assigned by the batcher. During rendering, this name will become the filename.
- The image column displays a miniature image of the snapshot to be rendered. The rendering engine that will be used (OpenGL or Raytracing) is indicated on the upper part of the miniature. In the lower right-hand corner, a symbol represents the type of snapshot.
- The **Parameters** column provides the following information:
 - image size,
 - file format,
 - snapshot type,
 - render engine used for the snapshot (OpenGL or Raytracing) and engine specific options,

The list of snapshots can be ordered alphabetically by column by clicking on the column header.

Double-clicking on a snapshot in the **Snapshots** box restores the snapshot in the active viewport with that of the snapshot and opens the editor that produced the snapshot. According to the type of snapshot created, the following information, saved at the moment the snapshot was taken, is restored.

Type of snapshot	Information
Image snapshot	<ul style="list-style-type: none"> • image size, • render engine used for the snapshot (OpenGL or Raytracing) and engine specific options, • point of view, camera specific parameters and depth of field, • product's aspect, position, environment, overlay, and geometry layer visibility, • clipping planes and real-time sun settings.
Video snapshot	<ul style="list-style-type: none"> • image size, • render engine used for the snapshot (OpenGL or Raytracing) and engine specific options, • animation frame rate, • camera path and specific options, • product's aspect, position, environment, overlay, and geometry layer visibility, • clipping planes and real-time sun settings.
Cubic VR panorama snapshot	<ul style="list-style-type: none"> • render size, • render engine used for the snapshot (OpenGL or Raytracing) and engine specific options, • cubic VR panorama specific options, • product's aspect, position, environment, overlay, and geometry layer visibility, • clipping planes and real-time sun settings.
Snapshot VR Object	<ul style="list-style-type: none"> • image size, • render engine used for the snapshot (OpenGL or Raytracing) and engine specific options, • camera path, • VR Object specific options, • product's aspect, position, environment, overlay, and geometry layer visibility, • clipping planes and real-time sun settings.

Selecting Snapshots

The Snapshot Batcher differentiates between the current active snapshot and the captures selected for rendering.

The current active snapshot is designated by clicking on it. It is shown with a light gray background or surrounded by a dotted border.

The selected snapshots are marked with the  selection icon in the **Snapshots** box.

To select or deselect a snapshot, click within the space of the first column to show or hide the selection icon.

Snapshot Context Menu







Right-clicking on one of the snapshots brings up the **Snapshot** context menu.

This menu, which affects the current active snapshot, allows the user to:

Operation	Description
Render current snapshot item	Clicking on this option opens the Save options dialogue box containing the save settings. This rendering operation does not delete the snapshot from the Snapshot Batcher .
Duplicate snapshot	The text "Copy" is added to the name of the duplicate snapshots.
Rename snapshot	You cannot have multiple snapshots with the same name.
Delete snapshot	The programmed capture will be deleted.

Operations Toolbar

This toolbar provides the tools to lance rendering and to manage the selected captures in the **Snapshots** box.

Icon	Function	Description
	Render snapshots	Launches the rendering for all of the selected snapshots. Clicking on this button opens the Save options dialogue box. This dialogue box contains the save settings for the snapshots to be rendered.
	Select none	Unchecks the selection boxes for all of the snapshots in the Snapshots box.
	Select All	Checks the selection boxes for all of the snapshots in the Snapshots box.
	Rename snapshot	Renames the current active snapshot in the Snapshots box. You cannot have multiple snapshots with the same name.
	Duplicate snapshot	Duplicates the current active snapshot in the Snapshots box. The text "Copy" is added to the end of the name of the duplicate snapshots.
	Delete snapshot	Deletes the current active snapshot.

Adding and Modifying Snapshots Using the Snapshot Editors

Snapshots are added to the **Snapshot Batcher** using the various snapshot editors: **Snapshot Image**, **Snapshot Video**, **Snapshot VR Object**, or **Snapshot Cubic VR Panorama**. These editors can be accessed via the **Snapshot** menu.

The validation buttons are located at the bottom of each of the editors.

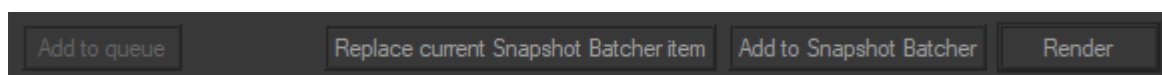

Validation buttons in the snapshot editors

The **Replace Current Snapshot Batcher Item** button replaces the active snapshot in the **Snapshot Batcher** with the snapshot created by the open snapshot editor.

The **Add to Snapshot Batcher** places the current capture parameters from the **Snapshots** box of any snapshot editor in the **Snapshot Batcher** for rendering at a later time.

Rendering from the Snapshot Batcher

Launch the rendering of the selected snapshots by clicking on the **Render snapshots** button . The **Save options** dialogue box will open.

The **Output directory** sets the directory in which the snapshots are saved. The image files for the snapshots are named after the corresponding view.

When **Confirm overwrite** is not checked, all files with conflicting names in the output directory automatically are overwritten. If Confirm overwrite is checked, you are asked confirmation for each conflicting file before rendering. If you choose not to overwrite a file, the rendering for the corresponding view is skipped.

Once the saving options are set, click **OK** to start rendering. Clicking on **Cancel** closes the **Save options** dialogue box and brings you back to the **Snapshot Batcher**.

During the rendering, a dialogue box displays the operations performed, along with any potential errors and warnings.

Raytracing Settings (Editor)

Available in: **Matter**: left toolbar >  **Raytracing Settings**



Ray tracing calculates how light propagates and bounces (reflection, refraction) in the scene to obtain a true-to-life image.

The **Raytracing Settings** window contains all parameters needed to configure the rendering.

Rendering



In the **Rendering** box, the adjustable parameters are:

Parameter	Description
Mode	Selects the rendering engine between the Ray tracing and Path tracing. Use the Enable GPU Ray Tracing rendering  button. Click again  to stop the rendering.
Min samples	Sets the number of times a pixel is recalculated to reduce noise. The higher the number, the sharper the image will be, though it will also increase the rendering time.
Global illumination	Activates the calculation of light bounces between surfaces, such as reflected light from a colored wall, and slightly illuminates a nearby object. Global illumination greatly improves the realism of the scene at the expense of rendering time.

Adaptive Sampling



The **Adaptive Sampling** option adjusts the number of samples per pixel according to the complexity of the scene.

Parameter	Description
Noise threshold	Defines noise tolerance: the higher the value, the noisier the image will be.
Minimum number of samples	Sets the minimum number of samples received per pixel before applying adaptive sampling. In other words, it guarantees a minimum number of samples per pixel to ensure basic quality before optimization.

Denoiser

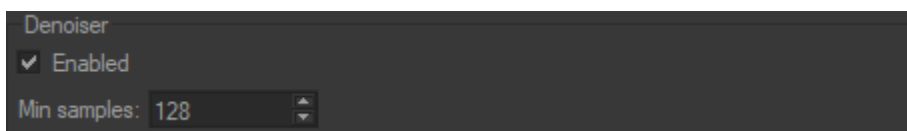

The **Denoiser** uses AI to remove noise from images.

Parameter	Description
Minimum number of samples	Sets the minimum number of samples received per pixel before applying the denoiser. In other words, it guarantees a minimum number of samples per pixel to ensure basic quality before optimization.

**TIP**

To maintain a natural look with the denoiser, leave enough samples/path traces before activating the denoiser to avoid smoothing too early.

Ray Rebounds

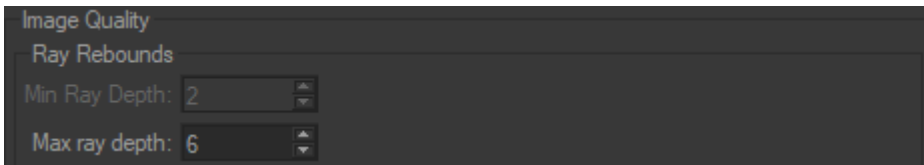

In the **Ray Rebounds** box, the adjustable parameters are:

Parameter	Description
Min Ray Depth	<div data-bbox="593 875 639 920"></div> <p>NOTE Only available for the Path tracing.</p> <p>Sets the minimum number of bounces before the ray is stopped if its contribution is too low.</p>
Max ray depth	Sets the maximum number of rebounds to reach.

**TIP**

To achieve a compromise between the desired quality and rendering time, start by defining the **Max Ray Depth** to achieve, which, depending on the settings, affects the calculation time.

Reflections

**NOTE**

Available for Ray tracing only.

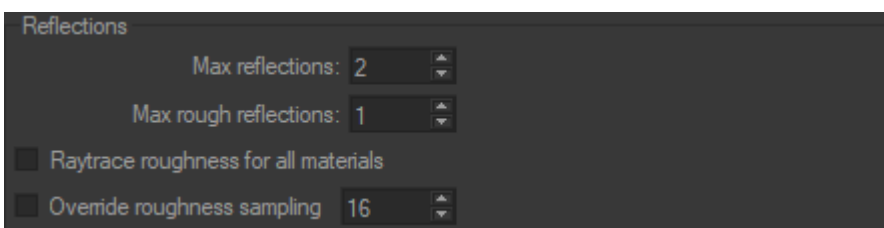

In the **Reflections** box, the adjustable parameters are:

Parameter	Description
Max Reflections	Maximum number of reflections allowed during calculation.
Max Rough Reflections	Maximum number of rough reflections allowed during calculation.
Raytrace roughness for all materials	Activates the calculation of the roughness by ray tracing for all materials without taking into account the parameters set in the Raytracing tab from the Materials editor.
Override roughness sampling	Allows you to ignore the roughness sampling value set in the Raytracing tab from the Materials editor. This applies to all materials.

It should be noted that setting the maximum number of rough reflections and transmissions to a high value will drastically increase computation time. Rough reflections and transmissions exponentially increase the number of traced rays. If a ray is sent through a ground glass with a transmission roughness value set to 100, 100 rays will be generated for the first hit, and then 100 other rays will be generated when each of these rays will touch the rear face of the glass. More than 10000 rays will be therefore used to compute a single pixel. The **Max Rough Reflections** and **Max Rough Transmissions** parameters should thus be used with caution to reduce computation time.

When a pixel is rendered, reflections and transmissions are computed until **Max Recursion level**, **Max Reflections**, or **Max Transmissions** is reached. The **End of course color** parameter from the last material hit is then used to determine if either a predefined color or the environment should be used to compute the render. The **End of course color** parameter is set in the **Raytracing** tab of the **Material editor**.

Transmissions

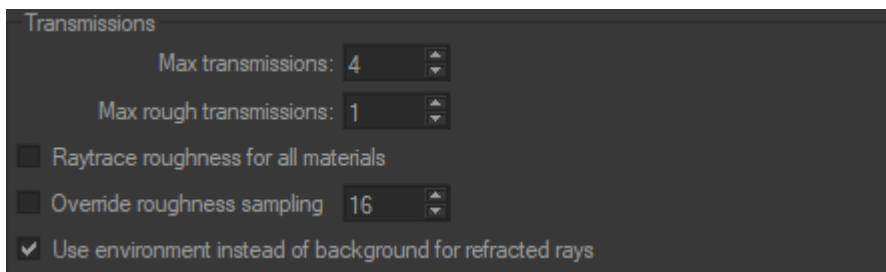

Similarly, the following parameters can be set in the **Transmissions** box:

Parameter	Description
Max Transmissions	Maximum number of transmissions allowed during calculation.
Max Rough Transmissions	Maximum number of rough transmissions allowed during calculation.
Raytrace roughness for all materials	Activates the calculation of the roughness by ray tracing for all materials without taking into account the parameters set in the Raytracing tab from the Materials editor.
Override roughness sampling	Allows you to ignore the roughness sampling value set in the Raytracing tab from the Materials editor. This applies to all materials.

Parameter	Description
<i>Use environment instead of background for refracted rays</i>	Conditions the behavior when rays pass through a transparent surface. When activated, the refraction of rays that pass through a transparent surface redirects them to the light environment rather than to the background. In cases where there is a significant color difference between the light environment and the background, this may cause unwanted effects. Therefore, it is possible to ignore the refraction of rays passing through transparent surfaces by unchecking this.

Clipping Planes (Editor)

Available in: **Matter: Editors > Advanced > Clipping Planes**

Clipping Planes is an editor that allows you to section the object of the scene in a pre-designated plane in order to see its interior.

Active clipping planes are visible in all open viewports and will clip through all products.



NOTE

Clipping planes are positioned in the world. Consequently, modifying the position of a geometry in the world will not move the plane. The position at which the plane clips the element will be modified.

General Settings for Clipping Planes

The **General Options** zone provides render settings with the **Face Elimination Policy** function, which allows you to show or to hide the backfaces of the surfaces.

In the **Face Elimination Policy** drop-down list, the option **Surfaces** displays backfaces according to the settings provided in the **Surface Properties [218]** in **Shaper**.



The **Show Gizmo** option displays a translation gizmo that can be manipulated to quickly move the plane of the active section.

The **Tags** section can be used to prevent surfaces from being clipped by the plane. Use the button to open a list of tags; select the tag that marks the surfaces that should not be clipped. Tags are assigned to surfaces using the **Tag Manager [186]** in **Shaper**.

Patchwork 3D Design allows the management and display of several Clipping planes simultaneously. Each plane is listed separately, followed by indicators for the clipping plane's state (enabled or disabled), the visibility of its contour, and the visibility of its grid. Clicking on the indicators modifies the state of the associated property.

Plane	Enabled	Contour	Grid
Plane 1	✓	✓	
Plane 2		✓	
Plane 3			✓

Settings for the Selected Plane

The **Enabled** function in the **Clipping Plane** zone must be checked to view the clipping plane.

The **Clipping Plane** zone provides the planar equation used to define the clipping plane. You can modify it by providing new numerical values.

Alternatively, you can choose a cross-section plane in the **Select the Plane** zone:

- Select the desired cross-section plane in the drop-down list.
- Via the function **Pick Plane**, you can perform a cross-section starting with a plane directly selected in the active viewport, using the eyedropper tool, or alternatively a precise cross-section point by checking the **Position** option.



NOTE

The cross sections are represented automatically in the interactive view each time the eyedropper tool is used.

Creating a Contour

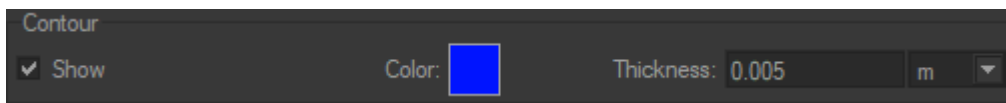

The contour of the clipped surface edges can be visually represented by enabling the **Show** option within the **Contour** zone. The color of the contour can be modified by clicking on the colored square to open the color selector. You can also modify the thickness of the line by entering a numerical value, or by using the up and down arrows of the keyboard.

Additional Display Options

The **Plane** box proposes a set of display options for the active cross-section plane.

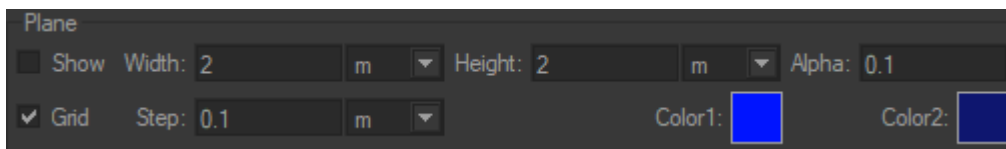

Thus the display of a plane can be activated (**Plane** zone > **Show** checkbox) and the value of its transparency (**Alpha** field), size (**Width** and **Height** fields), orientation, and Color of its representation (**Color1** and **Color2**) can all be modified. Alternatively, just a metric Grid is displayed (**Grid** and **Step** options).

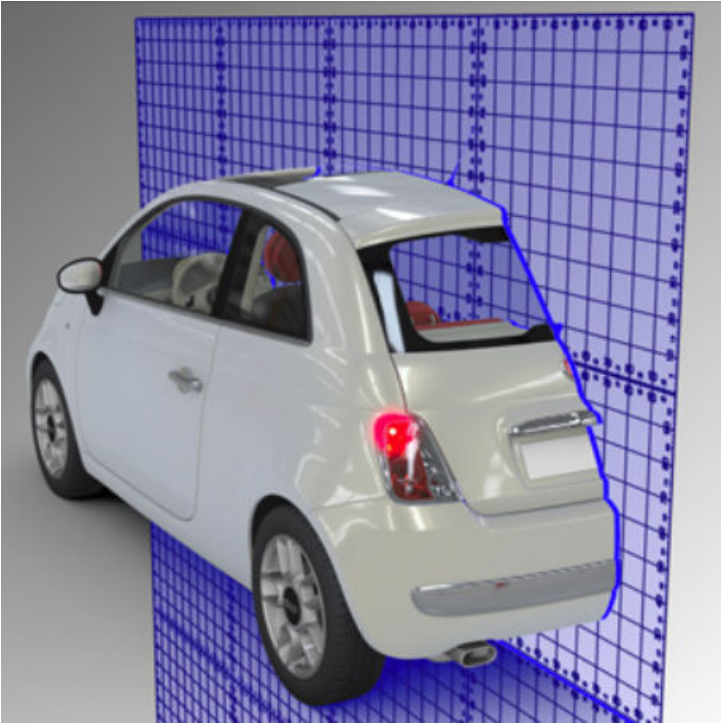





Post-Processing (Editor)

Available in: **Matter: Editors > Post-Processing**





Post-Processing  is an editor used to create, enable/disable, combine, program and assign 2D post-processing effects interactively. It creates and modifies a blend of effects, their properties, and the way they are combined.

Once post-processing blend is assigned to the Patchwork 3D scene, viewing of the created effects is instantaneous; adjustment of the various effects is done in real time.

Function	Description
	Start point for assignment by drag-and-drop.
<div style="background-color: #e0f2f1; padding: 10px;"> <p> TIP Assignment of a post-process is also possible from Matter sidebar's post-processing library. See Post-Processing Library [392] for more information.</p> </div>	
	Allows an post-processing blend to be selected with a click on the viewport in which it is active.
	Creates a new post-processing blend.

Function	Description
	Duplicates the active post-processing blend.
Text field	The text field is for renaming the active post-processing blend.
Apply to background	Enables or disables the application of the post-processing effects to the background in the Patchwork 3D scene.
Apply to overlays	Enables or disables the application of the post-processing effects to the overlays in the Patchwork 3D scene.

In the **Post-Processing Effects** box:

Function	Description
	This toggle button is for enabling/disabling a specified post-processing effect. This icon indicates that the effect is enabled.
	This icon indicates that the effect is disabled.
	The New effect button is for adding a new effect to the post-processing currently being edited. Many effects are available. See the chapter Post-Processing Effects [389] .
	The Solo effect toggle button is for momentarily isolating the selected effect. A green frame around the 3D view indicates that only the isolated effect is displayed.
	The Delete effect button is for deleting the selected effect from the list of post-processing effects in the blend being edited.
Effect properties zone	The effect properties frame is for precisely defining the various parameters contained in a post-process, by assigning precise numerical value.



TIP

For post-processing that require settings on the size of the effect, it is possible to adjust the effect relative to the size of the image with % **width**, % **height**, and % **default** parameters. % **default** uses height or width based on the default orientation of the current camera.

Advanced Menu

The **Advanced** sub-menu gives access to the various tools and options for combining several effects with one another.

The rendering possibilities are numerous and the effects obtained can be extremely variable depending on the parameters used for combining the effects.

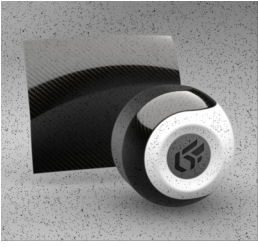

Typical effect obtained by combining effects: Film grain + Edge detector + Tone Mapping + Hand drawing + Get 3D image.

Get 3D image is for restoring the initial 3D image (without post-processing).

Store current result is for saving the image with the combination of activated effects.

Restore saved result is for restoring the image with the previously saved combination of effects.

Combine with saved result is for combining the image obtained by the latest activated post-processing effect with the previously stored image.

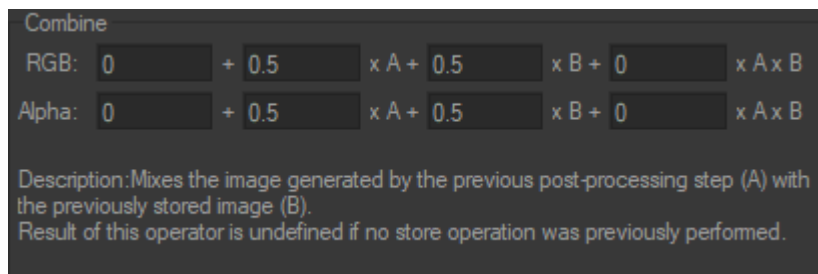

The associated parameters are for precisely adjusting the influence of one image relative to the other.

Multiply/Add is for adding or multiplying the image by a factor.

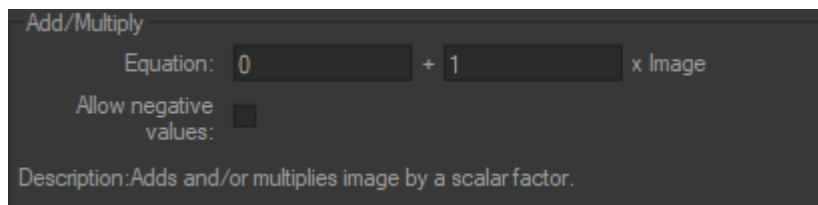

Grain generator is for generating grain (simple filter used in the photo grain advanced filter).

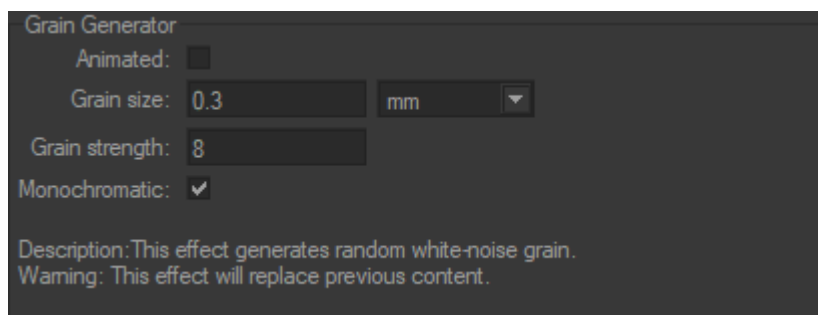

Database Properties (Editor)

Available in: **Shaper** or **Matter**. **File** > **Edit Database Properties**

Each database possesses a set of properties concerning the displayed rendering, the color management, and the database format and creation. This information can be viewed or modified in the Database Properties.

Rendering Tab

A database's rendering options are used to optimize Patchwork 3D's performance with certain less powerful hardware configurations. In the **Rendering** tab, the options **Force texture dimensions in powers of two** and **Reduce Lightmap Size** work to limit the resources required for rendering.



WARNING

These options are intended for advanced users. Enabling these options can affect your rendering in unexpected ways, particularly where smaller databases are concerned.

Color Management Tab

The colorimetric profile defines the interpretation of the color values (RVB, CMYK or LAB) by matching them with measurable physical quantities (expressed in the space CIE XYZ or LAB). For the rendering and adjustment of materials displayed on the screen to be consistent with the colors and the shades of the real materials, it is essential to work in a defined colorimetric space. Patchwork 3D provides tools for defining, installing and managing the colorimetric profiles of the workspace, of imported images and of images produced by the software.

In this tab, you can consult and modify the profiles used by the open database.

To set the behavior concerning **Color [60]** management profiles for new databases, refer to the settings available in the Color tab of the **File** > **Settings** menu item.

Application Tab

This tab contains information on the origins of the open database. The name and version of the application with which it was last saved are displayed.

Environment Properties (Editor)

Available in: **Matter**: sidebar environment library > **Edit**

The **Environment Properties**  is an editor used to modify the properties of the active lighting environment.

Certain HDR environment properties are updated in real time as they are modified. These properties are indicated below.

General Properties

General Properties can be applied to all global or local environments.

General Properties:

Property	Description
Name	Displays the name of the environment. This name can be changed by providing a new name in this field. Use the Enter key to validate any changes.
Gamma	Allows you to change the gamma value of your image. Useful in some cases for correcting the gamma value of the imported HDRI image.
Saturation	Allows you to adjust the color saturation of the environment image. Its value varies from 0 (environment image in black and white) to 1 (environment image in saturated colors). This property can be adjusted in real time.
Mapping Type	Allows you to define the projection method for the type of HDRI image.
Invert	Allows you to invert the projection of the environment image.
Default Orientation	Initializes the orientation of the environment in order to position it correctly with regard to the product.

Diffuse:

Property	Description
Exposure Correction	Allows you to adjust the influence of the exposure of the environment on the diffuse layer of a material. It is a coefficient applied to this contribution. This property can be adjusted in real time.
Lightmap Coloration	Allows you to adjust the influence of the environment color on the diffusion of the materials using lighting textures.

Specular:

Property	Description
Exposure Correction	Allows you to adjust the influence of the exposure of the environment on the specular or reflection layer of a material. It is a coefficient applied to this contribution. This property can be adjusted in real time.
Resolution	Allows you to define the resolution of the image used for adjusting the mirroring.
High Quality Filtering	Eliminates whitening and aliasing effects environment reflections on sharp geometries in scenes with very intense areas.



Reflection of an environment featuring a high intensity area in a specular material without the High quality filtering option.



Reflection of an environment featuring a high intensity area in a specular material with the High quality filtering option.

Background:

Property	Description
Alternative background map	Allows a high resolution texture in a low dynamic range format (JPG, PNG...) to be used instead of the HDR environment for environment materials.
Exposure	Allows you to adjust the influence of the exposure of the environment on the background. Its value is a coefficient applied to this contribution. This property can be adjusted in real time.
Altitude	Allows you to adjust the altitude of the background.
Resolution	Allows you to define the resolution of the image used for the background.

The image below illustrates the impact of the general properties on the render:



Here the red light source is placed out of the viewport, to the right of the image. This red component can be seen bleeding across the white bodywork.

Parallax Correction

Reflections generated by a local environment are calculated from the environment's position. However, the observer's position is often different from the environment's position. This may produce a visible difference between the physically realistic reflection of the environment and the reflection actually observed in the scene.

Parallax correction uses proxy surfaces in order to correct for the shift due to the use of different reference points for the observer and the environment.

Property	Description
Type	<p>The type of proxy surface to use:</p> <ul style="list-style-type: none"> • None: no correction, • Box: a cube, • Hemisphere: a hemisphere, <p>The settings for each type of proxy surface are discussed below.</p>
Automatic adjustment (...)	<p>When a box or hemisphere proxy surface is used, Patchwork 3D Design can estimate its required volume in order to match the environment zone as closely as possible. Run this operation using the ... button. It may be necessary to fine-tune the results.</p>
Gizmo	Show or hide the highlighting of the proxy surfaces.

Box

Use a box as a proxy when the space that should be used for the environment is mostly box-like.

Boxes are always aligned on the grid. They are defined by their minimum and maximum values along the X, Y and Z axes.

In the corresponding fields, enter the minimum and maximum coordinates along the X, Y and Z axes.

Hemisphere



Use a hemisphere as a proxy when the space that will be used for the environment is similar to a hemisphere shape.

A hemisphere is defined by the length of its radius and by the position of the hemisphere's central point.

Provide the coordinates for the central point, and indicate the length of the radius.

Local Environment Properties

Local environment properties set the capture zone for a local environment.

Icon	Property	Description
	Product	Associate the environment with an existing product. Drag and drop the product onto this field.
	Dynamically rebuild when configuration changes	Activate automatic updating for the local environment when changing configurations. This insures visual coherence in the reflections of geometries, colors and lighting in the scene when the displayed configuration is modified.
	Position	Set the origin point at which the local environment will be captured by providing the origin's XYZ coordinates.
	Display and move the capture box	The capture box makes it easier to visualize the zones from which the local environment images are going to be captured. It can be repositioned with the mouse.
	Pick the capture origin	Set the origin point of the local environment capture in the viewport using the eyedropper. The X, Y, and Z values of the clicked point are automatically entered in the Position fields.
	Refresh environment	Update the environment by recalculating the images captured by the local environment box.
	Radius	Adjust the size of the capture box.
	Resolution	Block the resolution of the environment texture at a chosen resolution. Select the desired resolution from the list.
	Exclude surfaces with tags	If the surfaces of an object around which an environment local is assigned have been tagged, they can be ignored by the local environment. Provide the tags of these surfaces here.

For more information on tags, see [Tag Manager \[186\]](#).

Surface Properties (Shaper Editor)

Available in: *Shaper: Surface > Properties (P)*

Surface Properties displays and edits the properties of the selected surfaces. This editor is composed of three tabs and an information zone.

Each surface has several properties listed in the zone labeled **Information**:

- Its name,
The name allows for rapid identification of a surface, both in **Shaper** and in **Matter**.
- Its drawing color in **Shaper**,
- A comment (initially, the name of the import file), The comment contains, once a surface has been imported, the path to the source file.
- The layer to which it belongs,
- The type of surface.

Its name and comment can be modified by clicking in the text field and typing a new value.

To change the **Shaper** drawing color, you have access to a color chooser:

1. Select a color, either by clicking on it in a color palette or in a color book, or by setting it in the color picker on the left.
2. To validate the selection and close the color chooser, click on the **OK** button.

The button **Reset** allows you to return at any time to the original color.

Lighting

In this tab, set the default behavior of this surface when lit.

By default, all surfaces created **cast shadows** and **receive shadows** unless these values are overridden for a given surface. This behavior can be modified by unchecking the boxes here.

Default lightmap format and size options are also available. The lightmap size is determined by Patchwork 3D based on the size of the surface.

The **Factor** option allows the calculated size to be increased or decreased. The values available are multiplicative values applied to the length and to the width of the lightmap. Consequently, a factor of **2** will double the length and the width of the lightmap, for a total size increase of four. A factor of **0.25** will divide the total lightmap size by four.

Increasing the size makes a lightmap more precise but requires more computational time and takes up more disk space. Maximum size for lightmaps is set in the application settings. However, you can impose a different limit for this surface in the **Max size** field.

Geometry

The **Geometry** properties of the surface:

- Its scale initially defined on importing,
The scale of a surface is the same used in the CAD tool used to model the surface. The scale of a surface is generally detected automatically during the CAD import. However, it can be subsequently modified.
- The number of points and triangles used to represent it.
The number of points and the number of triangles give information regarding the fineness of the lattice structure used to represent the surface.

The **Symmetry** properties of the surface:

- Whether the symmetry is enabled or not,
- The plane of symmetry (XY, YZ, ZX),
- The position of the plane of symmetry.

The **Animated Mesh** properties of the surface:

- The default frame to display, if the surface is an animated mesh. The frame corresponding to the slider position is used as the default visual for the surface. The frame number is also displayed to the left.

Display

Surface **State** properties:

- **Hidden**,
- **Frozen**.

Just like the layers, the surfaces can be frozen or hidden individually. Each surface has two boxes: the first encodes the visibility, the second the freezing. In order to be visible, a surface must belong to a visible layer. It is editable if it is not frozen and if the layer to which it belongs is not frozen either.

The **Optimization** properties:

- Removal of the hidden faces (backface-culling),
Surfaces use global default settings of the model for the backface-culling (disabled by default). However, you can enable or disable this optimization for one or more surfaces by changing the **Force to show backface** or **Force to hide default backface** respectively.
- Simplified display: drawing of the bounding box.
When the lattice structure of a surface comprises a high number of triangles and points, its display may become overloaded. You can simplify the representation of a surface in **Shaper** by enabling the **Display as Box** option: the surface is no longer represented by its lattice structure but by its bounding box.

Billboard properties:

- **None**, **Rotate Y**, or **Rotate XY**

Properties of a Selection of Several Surfaces

If several surfaces are selected, you can modify their color, their scale, their state and their display properties.

Surface Properties (Matter Editor)

Available in: **Matter**: right-click on a surface > **Edit properties**

When you right-click on a surface and choose **Edit properties**, an editor appears. From this editor, you can edit the surface's properties.

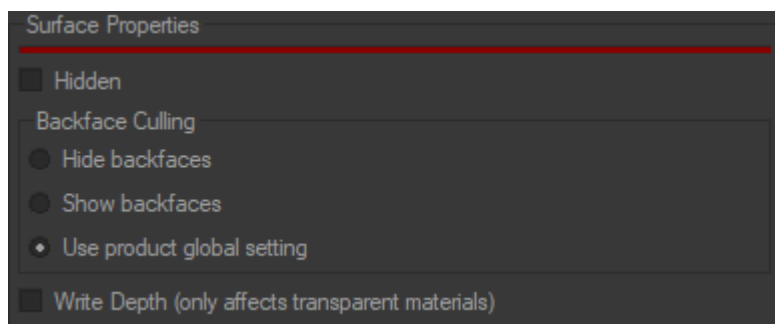

Visibility

This property indicates whether the surface is visible. It is taken into account only if the property of the **Visibility** of the different surfaces product is enabled.

You can modify this property by:

- **Visibility** in the viewport context menu (right-click on a surface),
- Using the **Click to Hide** mode.
- Running the **Show All** operation available in the **Visualization** menu or the viewport context menu.

Backface Culling

This property enables the removal of the faces that are not oriented toward the observer. This removal of the rear faces consequently improves rendering speed.



Open volume: Only front (outer) faces are visible.



Open volume: The transparent top surface's front face is visible, and the bottom surfaces front (outer) and back (inner) faces are visible.

A rear face is generally obscured by one or more front faces in a closed volume. If a face becomes transparent (application of a transparent material), it no longer performs its occlusion function. It is then essential to make the front and rear faces visible in order to close the volume.

Backfaces use the default global settings. See **Use product global setting**.

This parameter can be changed for each surface with the **Backface Culling** available in the viewport context menu:

- **Hide backfaces**
- **Show backfaces**

Depth Writing (Transparent Materials Only)

This property, which is available from the viewport context menu, indicates that the surface leaves its imprint in the depth buffer. It is most importantly used for solving transparency conflicts. This property is modified by the **Write depth** option in the viewport context menu.

Transforming a Material

The **Transformation** zone allows you to manually position a material on a surface, by directly modifying the numerical values U and V and also the rotation values in the **Surface Properties**.

With this, you have the capability of rotating and moving a material precisely and interactively by means of the keyboard.

Product Properties (Editor)

Available in: **Matter: Editors > Advanced > Product Properties** (F8)

Product Properties is an advanced editor used to override surface property settings from **Shaper** when viewing the product.

The product name displayed at the top of the editor indicates which product is being edited. The product name can be modified from this field.

Property	Description
Has its own surface visibility	When this option is checked, surface visibility states in Shaper are ignored. This enables you to hide a surface in Shaper , but still view the surface in Matter , allowing you to work on your model simultaneously in Shaper and in Matter.



TIP

When this option is enabled, a surface may also be hidden in **Matter** but visible in **Shaper**. Set the visibility of a surface in Matter by right-clicking on it and selecting Visibility to change its state.

Baked lightmaps reach their limits when certain objects casting shadows are animated, or may appear or disappear according to the configuration. We implemented SSAO to break through these limits in addition to lightmaps.

The **SSAO** (Screen Space Ambient Occlusion) measures the amount of ambient light that is blocked by surrounding objects. If a surface is obscured by another object, less light will come to it and it will be darker. The SSAO, therefore, measures the obstruction or occlusion of indirect light on an object in order to reduce its amount of ambient light. Usually, corners, cavities, or edges of objects are geometries with a lot of ambient occlusions.

More exactly the SSAO approximates the ambient occlusion using the Z-Buffer, it evaluates the depth of the pixels around an area and then applies the occlusion to these pixels according to the samples taken from the surrounding area.

Depending on the approximation of the ambient occlusion you wish to make, enter a value for the **Radius**, number of **Steps**, and the **Bias**.

- The **Radius** is adjusted according to the area to be evaluated.
- The number of **Steps** is adjusted according to the proximity of the blackout object. A large number of steps results in a better quality of the SSAO but has an impact on performance.
- The **Bias** is an arbitrary parameter allowing to adjust the result of the SSAO.



Product without SSAO on the left and with SSAO on the right.



NOTE

You also have the possibility to add to the SSAO, the rendering of lightmaps by checking the dedicated box.

Keyboard Map (Editor)

Available in: **Shaper** or **Matter: File > Keyboard Map**

The Keyboard Map is an editor used to verify the default keyboard and mouse shortcuts and to modify them. By default, shortcuts are assigned to a small portion of the available actions. This editor can be used to assign shortcuts to any available operations or to remove shortcuts from actions you don't often use.

The **Keyboard Map** is divided into two tabs: **Actions** and **Navigation**.

Actions

In the **Actions** tab, on the left of this window is the list of operations used in Patchwork 3D. These operations are combined into several groups: **Application**, **Matter**, **Shaper**, **Surface Cutting Workshop**, **Unfolding Workshop**, and **Timelines**. The group selector allows you to display the operations of a group in the list of operations. By selecting an operation, its description, the associated icon and the assigned shortcut if there is one will appear on the right.

To assign a new shortcut to the selected operation, click the **Enter...** button and then press the desired key on your keyboard that you wish to use. The shortcut entered then appears in the **New shortcut** zone. If an operation is currently assigned to this shortcut, it is displayed in the **Currently assigned to** zone. By clicking the **Assign** button, this shortcut is assigned to the selected operation. An operation previously assigned to this shortcut is no longer assigned to it. You can remove the shortcut assigned to an operation at any moment by clicking the **Remove** button.

The system of predefined configurations allows you to easily load one of the keyboard configurations supplied by default with Patchwork 3D. The user configuration corresponds to the keyboard configuration that is currently being used in Patchwork 3D. Use the **OK** button to assign your new configuration to

the keyboard. Use the **Cancel** button to cancel any changes you have made. It is also possible to display the keyboard shortcuts in an HTML file by clicking the **Show as HTML** button.

Navigation

The **Navigation** tab displays the navigation modes that are accessible via shortcuts. The profiles in the list **Presets** list offer default choices among the shortcut navigation configurations used in 3ds Max, Alias, Maya, and Solidworks, as well as those used by default in the Patchwork 3D universe. The buttons **New**, **Rename** and **Delete** on the right manage the list of presets. Each preset configuration is fully editable.

Modifications are made in the same manner as in the **Actions** tab. To assign a new shortcut to a camera action, select the action from the list on the left. Select the mouse button, and, if necessary, the modifier keys for the navigation shortcut. If a camera action is currently assigned to this shortcut, it is shown in the **Currently assigned to** zone. By clicking the **Assign** button, shortcut is assigned to the selected camera action. A camera action previously assigned to this shortcut is no longer assigned to it. You can remove the shortcut assigned to a camera action at any moment by clicking the **Remove** button.

Render Quality Settings (Editor)

Available in: **Matter** : click on the following icon  at the top right of the viewport > **Render Presets** > **Edit Render Quality Settings**

The render quality settings establish the rendering strategy in the 3D viewport. These are advanced settings. Three preset profiles are available in the **Render Presets** submenu to simplify modification of the render quality settings:

- **Default**,
- **Fastest**,
- **Nicest**.

The presets cannot be modified or deleted. To use a similar profile, first copy the preset, then modify the new profile.

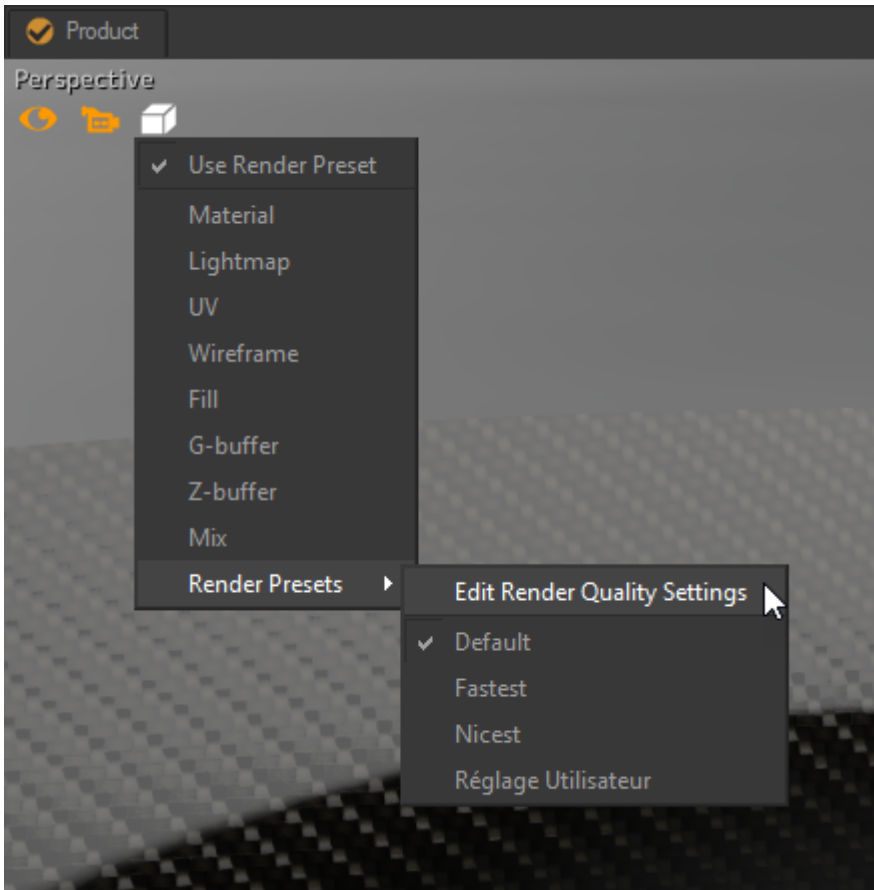

The top of the editor is dedicated to a preset profile management section:

- Drop-down menu: all of the existing profiles are listed,
- **New**: create a new profile,
- **Delete**: delete the selected profile. Preset profiles cannot be deleted.
- **Rename**: rename the selected profile,
- **Copy**: create a copy of the selected profile,
- **Make default**: set the selected profile as the default profile to use when opening a new viewport. This profile is saved in your application preferences and is also applied when you open a new editing session in Patchwork 3D.

The render settings in this editor are applied or disabled depending on the phase of your interaction with the 3D viewport. The current interaction or inactivity with the viewport constitutes the **context**, shown in the drop-down menu:

Context	Description
All	The settings displayed when the context All is selected are applied to all contexts. That is, they are always applied.
During interaction	The settings displayed when the context During interaction is selected are applied while you navigate or work in the 3D viewport.

Context	Description
At end of interaction	The settings displayed when the context At the end of the interaction is chosen are applied immediately when you stop navigating or working in the 3D view.
While idle	The settings displayed when the context While idle is selected are applied only when the viewport is inactive.

Each context is associated with a set of parameters:

Parameter	Description
Render Mode	<p>Imposes a rendering style. In addition to the Material mode, which is the standard rendering mode in Matter, all of the Shaper rendering options are also available:</p> <ul style="list-style-type: none"> • Wireframe: surfaces are represented schematically with plotting following the lattice structure of each surface. The surfaces are not mutually masked. • Smooth: the surfaces are shown smoothed out with solid faces, lit by soft lighting. • Smooth and Highlights: the surfaces are shown smoothed out, as solid faces with a specular reflection. • Facets: the surfaces are represented by their lattice structure, not smoothed out, as solid faces lit by soft lighting. • Facets and Highlights: the surfaces are represented as a solid lattice structure, not smoothed out, as solid faces with a specular reflection. • Lit Wireframe: the surfaces are represented by an illuminated wireframe plot of their lattice structure. • Bounding Box: each surface is represented by the wireframe plot of its bounding box. This rendering mode facilitates the handling of surfaces that have lattice structures comprising a large number of triangles.
Mirror reflections	Displays reflections in mirror materials when this option is checked.
Mipmaps	Allows the use of texture mipmaps. This option, which may use a significant amount of GPU memory depending on the capacities of your graphics card, improves the render of textures when they are displayed on the screen on a scale much smaller than their natural size. This is the case, for example, when they are applied to objects that are positioned far from the camera.
Post-Processing	Allows post-processing effects to be displayed.

Parameter	Description
<i>Real-time depth of field</i>	Activates the real-time depth of field, which applies to navigation and to the playback of animations.
	<div style="background-color: #e0f2f1; padding: 10px; border: 1px solid #ccc;">  <p>TIP For the depth of field to be displayed in the 3D viewport, the software antialiasing must be activated (see below). For an image snapshot, the option Antialiasing must be activated in the Snapshot Images editor.</p> </div>
<i>FXAA</i>	Enables or disables the fast approximate GPU antialiasing filter. It is best to use either the software antialiasing or the GPU's fast approximate antialiasing, but not both at the same time.
<i>Specular anisotropic filtering</i>	The slider's position set the level of samples for the specular anisotropic filtering. This filter is enabled when its value is greater than 1. It provides improved rendering for textures viewed and an oblique angle.

The parameter for the [software antialiasing \[461\]](#) is composed of multiple options:

Option	Description
<i>Enabled</i>	Enables software antialiasing when the checkbox is ticked.
<i>Progressive depth of field</i>	Displays the various stages of progressive render refinement during the calculation of depth of field (except real-time depth of field). This option is not recommended if you are also using <i>Real-time depth of field</i> .
<i>Samples</i>	Sets the level of definition via the number of renders per pixel of the final image.
<i>Wait time</i>	Sets the wait time before passing from the context <i>At end of interaction</i> to the context <i>While idle</i> . This delay does not include the time required by the refinement to the rendering, which can be consequential with certain configurations.

It is also possible to exclude certain types of materials from the render in a given context. By default, all material types are rendered. Untick the checkboxes of the materials to exclude:

- Error: the render when an error prevents the material from being displayed,
- Null opaque: the render when no material is applied to the surface,
- [Standard \[326\]](#) opaque,
- [Standard \[326\]](#) transparent,
- [Seam \[361\]](#),
- [Matte \[345\]](#),
- [Environment \[341\]](#),
- Opaque [mirror \[345\]](#),
- Transparent [mirror \[345\]](#),
- [Multilayer \[356\]](#),
- [Stickers \[363\]](#).

Selections (Editor)





Available in: **Shaper: Editors > Selections**

Selections is an editor used to save sets of selected **Shaper** objects.

This editor's interface consists of three tabs.

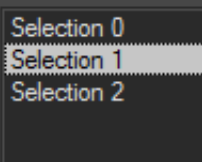
Saved Selections

The **Saved Selections** tab provides access to the operations on simple selections.

Operation element	Description
	This zone provides a list of the saved selections.
	The Create a saved selection button is for saving the currently-selected surfaces as a new selection set.
	This button allows you to update the active selection based on additions or deletions of surfaces you want to make.
	This button allows you to rename the active selection.
	The Delete a saved selection button is for deleting the active saved selection.



TIP

To activate one of these saved selections, double-click on its name in the list.

Selection by type

You can make a selection by:







- type of geometries (meshes or nurbs), objects (cameras, vectors, Bézier paths, etc...) and primitives (spheres, cubes, planes, etc...).
- group of geometries (meshes or nurbs) and primitives (spheres, cubes, planes, etc...).

Selection by lighting

Select here the surfaces that have lightmaps (**Select Surfaces with Lightmaps**) and the surfaces that do not have lightmaps (**Select Surfaces without Lightmaps**).

Regular Expression Selections

The **Regular Expression Selections** tab provides access to the operations on advanced selections by regular expressions.

Icon	Function	Description
	Save all the regular expressions	Saves all expressions of complex selections in a file. This allows the same expressions to be used in several databases.
	Open regular expressions file	Import and recall a saved file of complex selections.
	Create regular expressions group	Creates a new group of regular expressions.
	Delete regular expressions group	Deletes the selected group of regular expressions.
	Create regular expressions based selection	Creates a new regular expression to use as a selection criterion.
	Delete regular expressions	Deletes the selected regular selection expression.

Example

A selection of all the objects named box will have the following regular expression: **box***.

A group of regular expressions containing the following regular expressions: **box*** and **cyl*** will select in one go all the objects named box and all the objects named **cylinder**.



TIP

To activate a selection group by regular expression, double-click on its name in the list of regular expression groups.

Color Chooser (Editor)

Available in: **Matter** or **Shaper**: click on a modifiable color square

The **Color Chooser** is a tool that allows you to define, create, save, load, and manage colors.

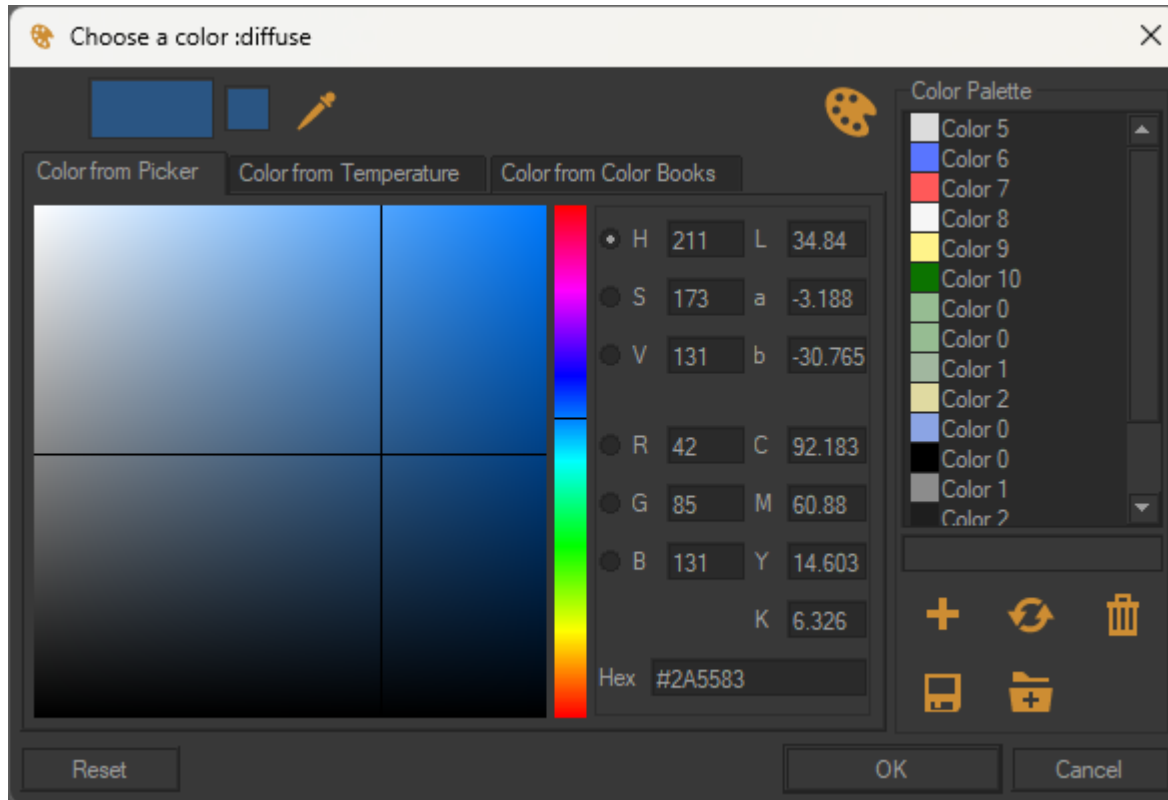

Example of a Color Chooser with the unfolded color palette.

The interface of the Color Chooser is divided into two parts:

- **Left part, the overview**







- At the top, the visualization rectangle (dynamic preview) displays the color currently selected and updated in real-time as the cursor moves through the color chart. It is the current color.
- To the right, the sample square shows the original color (the color that opened the Color Chooser). The color remains fixed and serves as a before-and-after marker. It is the previous color.
- The pipette  to sample color anywhere on your screen, inside or outside Patchwork 3D. Click on it to activate it and then pick up the desired color. A hexadecimal code appears under the pointer to make it easier to pick the color

- **Right part, the Color Palette**

Accessible via the button . The Color Palette groups the colors saved in your file for reuse.

Clicking on a color in the palette will load it in the color picker for use.

The buttons below the list of colors in the open palette allow you to manage the palette:

Button	Description
	This button allows a new color to be added to the palette. The new color will appear in the Color Palette list.
	TIP The color appears in the color palette. Each newly-created color is named by default: Color 1 . You can rename each color in the text zone situated below the color palette.
	This button allows you to update the selected color in the color palette with the hue you have set in the color picker to the left.
	This button deletes the selected color from the list of colors in your palette.
	This button saves color palettes in the KPL format.
	This button loads KPL files.
	TIP KPL files can also be directly loaded by drag and drop from Windows Explorer in the Color Palette tab.

Loading a KPL file in the **Color Palette** by drag-and-drop replaces the colors that are currently listed with those from the KPL file. To add the list of colors in a KPL file to the list of colors already present in the tab, hold down the **Shift** key during the drag-and-drop.

The buttons at the bottom allow you to save or ignore modifications:

Button	Description
OK	To validate your color selection, which appears in the rectangle to the left, and to close the color chooser, click on OK . This updates the color of the element that you are currently modifying.
Cancel	The Cancel button closes the color chooser without saving any changes.
Reset	The Reset button allows you to return at any moment to the initial color of the element, shown in the rectangle on the right.

Media

This short video demonstrates how to select multiple colors from the color chart in succession, and then sample another one using the pipette tool.

<https://youtu.be/EuZ0gPI80-A>

Color from Picker

The **Color from Picker** tab provides multiple ways of setting a color:

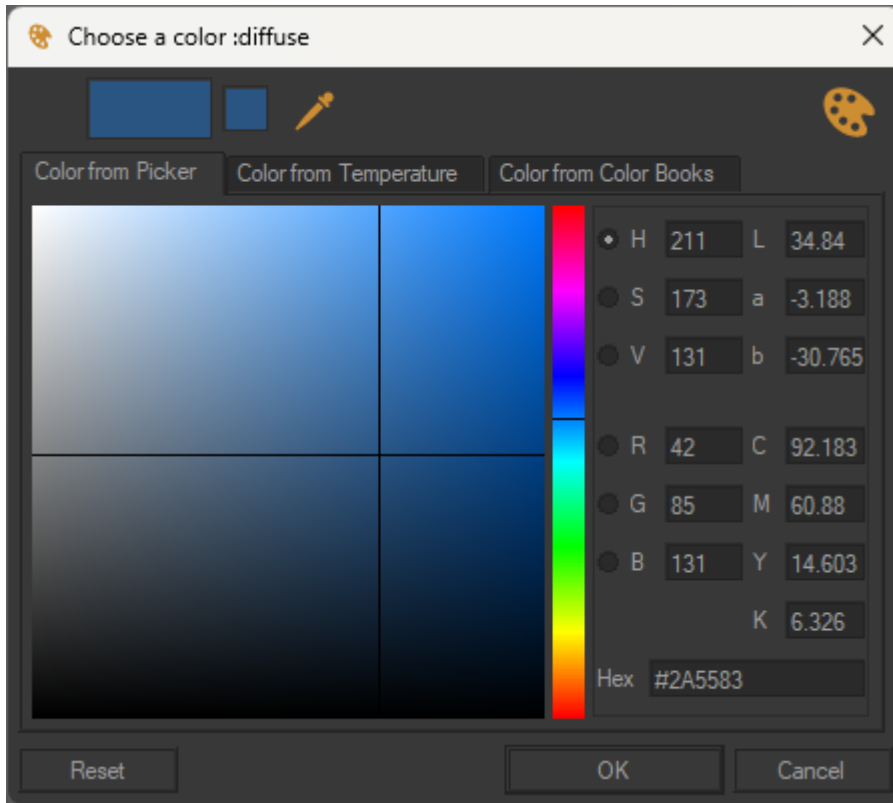

- Select a color hue, shade, and tint by clicking on the selector.
- Enter color values. Color values can be entered in the following formats:
 - HSV
 - RGB
 - LAB
 - CMYK
 - Hexadecimal

You can pick a color anywhere on your screen inside or outside Patchwork 3D with the eyedropper . To pick a color, just click on the eyedropper to activate it and then pick the desired color. A hexadecimal code appears under the pointer to facilitate color picking.

Color from Temperature

The **Color from Temperature** tab provides an alternative method of setting a color by choosing the temperature of a light source and applying the corresponding color.

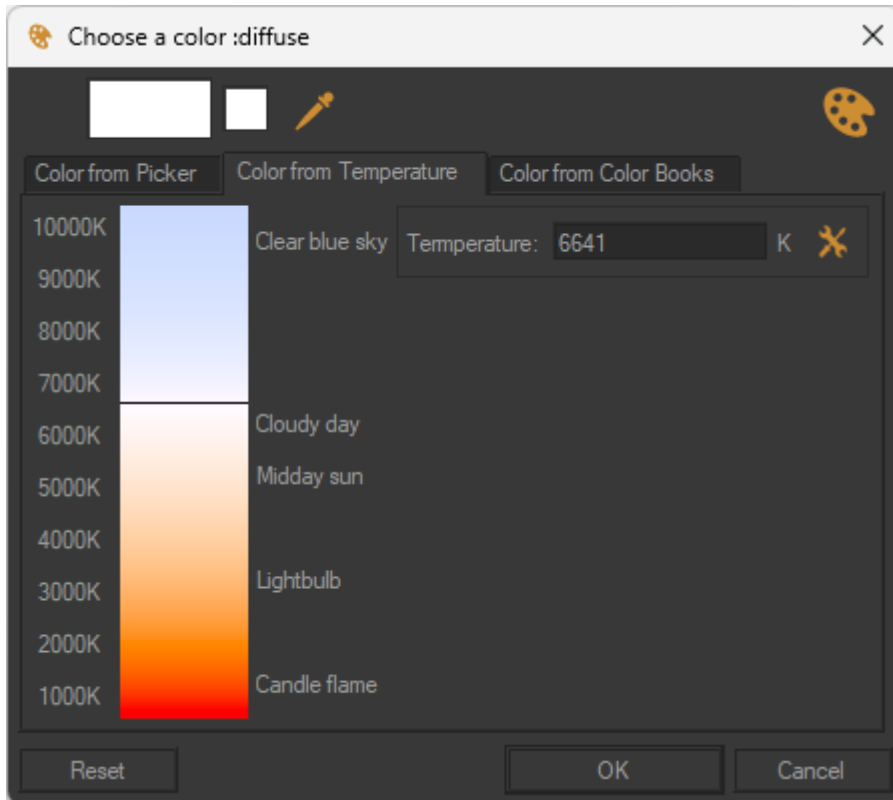

Use the slider or enter a temperature value in Kelvin. The button beside the **Temperature** field provides shortcuts to values for common color temperatures.

Color from Color Books

Patchwork 3D supports color books used by Photoshop in the **Adobe Color Book** format (ACB). In the **File** Tab of the Patchwork 3D **Settings** [54], you can set the access path to the Adobe directory where these color books can be found.

Color books present in this directory are accessible via the **Color Books** tab in the color chooser. Select your color book from the drop-down list in order to access the colors.







Layer Visibility Bookmarks (Editor)

Available in: **Editors** > **Layer Visibility Bookmarks**

Layer Visibility Bookmarks is an editor that stores sets of visibility states of geometry layers.

This editor's interface consists of an area for exploring layer visibility bookmarks and includes some simple tools for editing and enabling these bookmarks.

In the exploration zone, **Bookmarks**, the bookmarks are listed by name and can be selected. This zone contains the list of all existing layer visibility bookmarks.

Icon	Function	Description
	New	Creates a new bookmark. This button saves the current set of visibility states.
<div style="background-color: #e0f2f1; padding: 10px; border: 1px solid #ccc;"> <p> TIP To create layer visibility bookmarks, set each layer's desired visibility option directly in the Layers zone in the Shaper sidebar, then create a new bookmark.</p> </div>		
	Rename	Modifies the name of the selected bookmark.
	Sort	Sorts the list of saved bookmarks in alphabetical order by name.
	Activate	Loads the layer visible states saved in the selected bookmark.
	Refresh	Updates the selected bookmark by replacing the saved state with the current visibility states in the active viewport.
	Delete	Deletes the selected bookmark.

Real-Time Sun (Editor)

Available in: **Matter: Editors** >  **Real-Time Sun**

Real-Time Sun is an editor used to set up and display a sun that can be modified in real time in your products.



Example of real-time sun usage.

To spare memory usage, decrease the maximum size of lighting and shadow textures in **File > Settings > Lighting** tab. Default values are nevertheless desirable.

This editor is composed of five boxes: **Sun Settings**, **Shadow Settings**, **North Setting**, **Position**, and **Raytracing**.

This editor state is saved individually for each product. Data related to the **Real-Time Sun** is included in databases exported in KDR format.

Sun Settings Box

The **Sun Settings** box provides a set of adjustable parameters for creating a real-time sun.

Parameter	Description
On	Check the On box to activate the real-time sun in your product.
Color	Click on the Color box to open the color chooser and pick the color to assign to the sun.
Intensity	Enter in this field the value of the desired intensity of the sun. This value must be positive. Unlike the sun type lightings available in the Shaper module, intensity is adjusted according to the sun altitude.



Example of sun intensity variation.



NOTE

Real-time sun lighting is added linearly to the existing lightmaps in the model. If your model has very bright lightmaps, the effects of the sun will not be as visible.

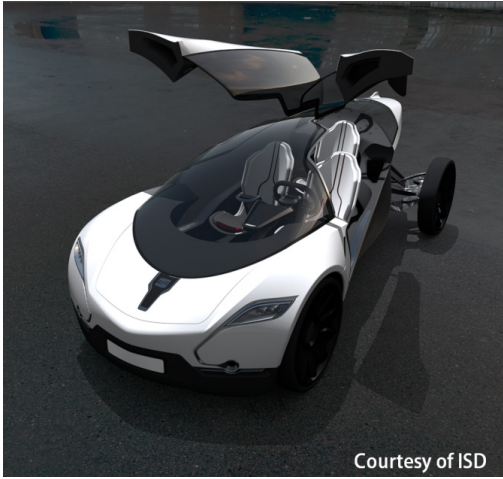
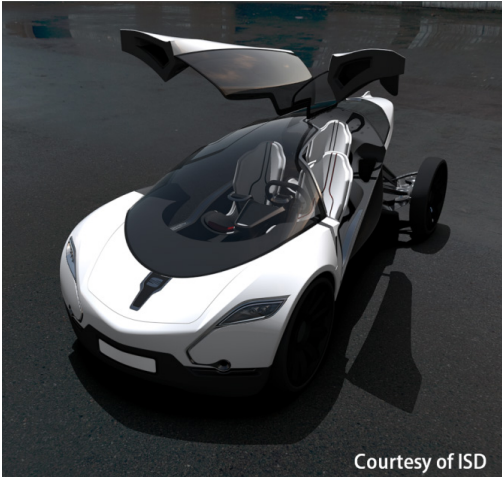
Parameter	Description
<p>Shadow intensity</p>	<p>By default, no light intensity is added to areas which are not sunlit. However, by entering a value in the Shadow intensity field, you can apply an additional light intensity in these shadow areas. The value entered must be positive. The value 0 corresponds to a realistic effect.</p> <div style="display: flex; justify-content: space-around; align-items: center;">   </div> <p style="text-align: center;"><i>Example of shadow intensity variation.</i></p>

Lightmap modulator

Adding a real-time sun to the lightmap of a product can produce an intensity of a lightmap that is too strong. If this is the case, you can modify the intensity of the lightmap. The field **Lightmap modulator** is used to set a modulation coefficient for the intensity of the lighting calculated in the **Shaper** module. The value of this coefficient must be between 0 and 1. The value 0 assigns a null intensity to the lightmap. The value 1 corresponds to the assignment of the lightmap as it is calculated in the **Shaper** module.

Specular

Tick this check box to display the sun's specular reflection on your product. Enter its intensity in the corresponding field.

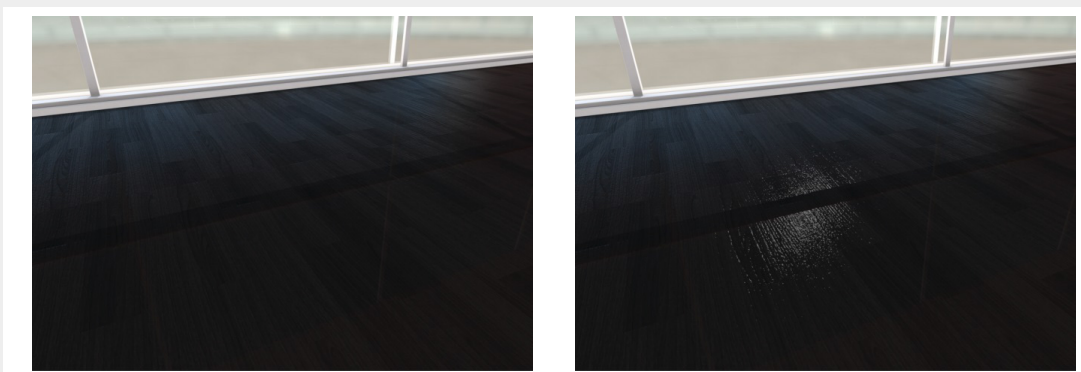

Example of a scene without and with the sun's specular reflection.

Shadow Settings Box

Parameters specific to shadows are included in this box.

Setting	Description
Shadows in mirrors	Tick this check box to display shadows on reflective surfaces. The activation of this option extends the rendering time.
Shadow quality	Select the quality of shadows to display from the drop-down menu. The higher the selected quality is, the longer the rendering time will be.
Shadow smoothness	Select the width for the blur effect on shadow edges from this drop-down menu. The more the shadows are smoothed, the longer the rendering time will be.

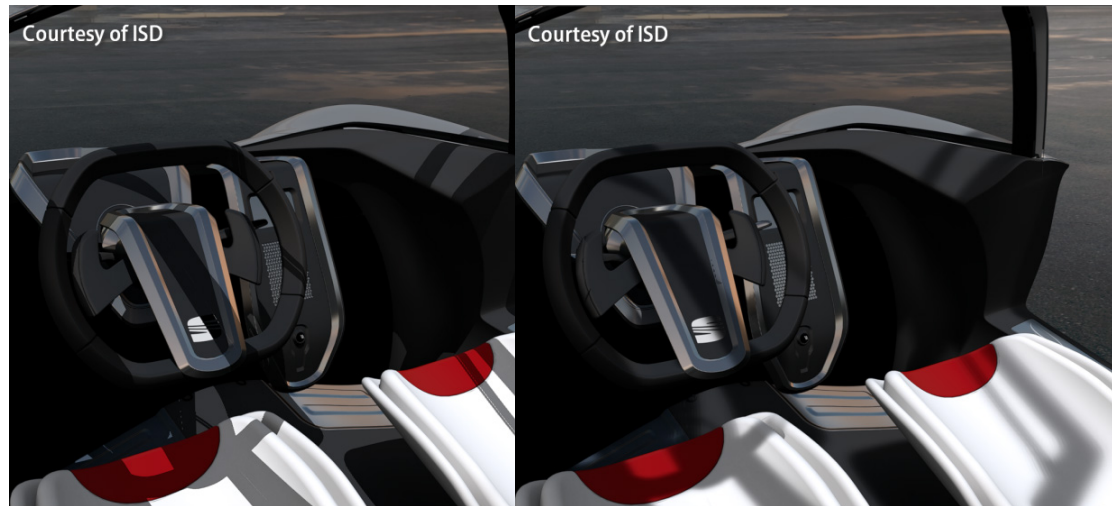

Examples of different smoothness in shadows.

North Setting Box

The **North Setting** box is used to set up the north relative to the reference axis of the database. There are three ways to set up the north direction:

- By entering a value between 0 and 360° for the angle between the X axis and the North arrow of the compass,
- By clicking on the compass while holding the left button of the mouse, and dragging it to the desired position,
- By clicking on the grid to define the orientation of the compass.

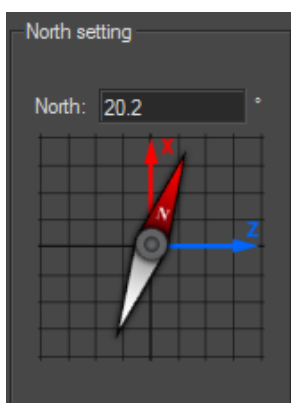

Positioning the compass at a 20.2° angle between the x axis and the compass.

Position Box

The Position box consists of three tabs, one for each sun positioning mode.

Manual Tab

This tab proposes to position the sun by entering a value for the **Azimuth** and the **Altitude**, or directly with the widgets by clicking or moving the sun to the desired position.

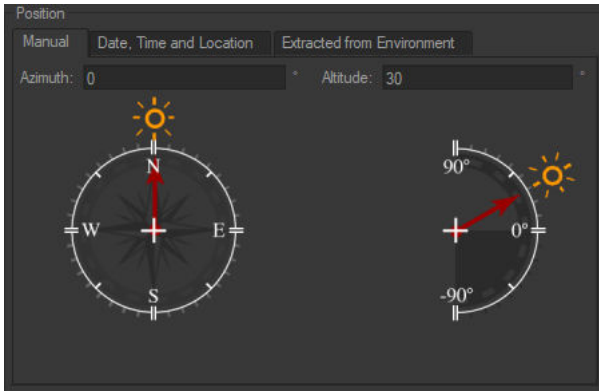

The Manual tab.

Azimuth is the angle in the horizontal plane between the sun direction and the north.

Altitude is the angle between the sun direction and its projection onto the horizontal plane.

Date, Time and Location Tab

This tab allows the sun to be located so as to mimic its position in the sky at a given date and time for a specific location. To do this, select or enter the date and time of your choice in the corresponding data field. Then provide the time zone with the drop-down menu. Areas of the world in darkness are updated on the map.

To activate the shift for daylight saving time, check the **Daylight savings** box and enter the value in minutes of the desired shift. This is only active on days when daylight saving time is applicable (from the last Sunday of March to the last Sunday of October).

Next, specify your location of choice:

- By entering values for latitude and longitude in the data fields – the **City** field then displays **User-defined**,
- By selecting a city in the **City** drop-down menu, or
- By clicking directly on a point on the map – the **City** field also displays **User-defined**.

Extracted from Environment Tab

Select this tab to position the sun at the point defined in the **Environment's Brightest Point** box in the **Product Environment Properties** tab of the **Product Environments** editor. Positioning the sun in the **Product Environments** editor is explained in the section [Environment's Brightest Point \[186\] Box](#).

Raytracing Box

The features in this box are used to activate the calculation of smooth shadows in the raytracing computation.

Check the **Use soft shadows** box to activate smooth shadows in the raytracing computation. Then, specify the desired **Sun angular diameter** and **Sample count** for the sun. The shadow smoothness increases with the angular aperture of the sun.

Overlays (Editor)

Available in: **Matter: Editors > Overlays**

Overlays  is an editor that enables the parameters of the active overlay to be edited.

The interface is divided into four zones:

- Operations bar and name of the active overlay: Displays operations available in the overlay library.
- **Global parameters**: Field for managing the alpha coefficient, which sets the level of transparency.
- **Layers**: Manages the appearance, placement and location of images used as an overlay, as well as any background gradation. You must create at least one layer).







TIP

As with other types of layers in Patchwork 3D, the layers in an overlay can be used to create configurations. To make overlay layers configurable, drag them from this zone and drop them in the **Configurations** editor, where they can be placed either in the target zone or in the rules zone to create a basic configuration. For more information, see the section [Configurations \(Editor\) \[176\]](#).

- **Map**: Used for managing the texture file and scale of the texture.

The following operations are available from the operations bar:

Icon	Description
	Start point for assigning an overlay by drag-and-drop to a sensor or to a viewpoint.
	Picking eyedropper used to choose, activate and edit an overlay used in a viewport.
	Apply the overlay currently being edited to the camera sensor in the active viewport.
	Create a new overlay.
	Duplicate the current overlay.

Overlays also includes functions that simplify editing:

- Clicking on the name of the **Map** in use leads to the current texture group in the **Matter** sidebar's texture library.
- The **Layer** visibility icon is automatically selected when a layer is created, rendering the layer visible by default.

Textures (Editor)

Available in: **Matter: Textures Library** (right-hand sidebar) > **Edit**

Textures is an editor that displays a texture in detail. Dragging and dropping a texture onto the interaction zone changes the texture visible in the editor.



Patchwork 3D includes metric dimensional management of textures which allows accurate association to the metric dimensions of physical materials.

The mapping modes (planar, box, circular etc.) and the **Unfolding Workshop** define the sets of UV coordinates on the metric scale. It is therefore necessary to verify the dimensions of the textures so that they precisely match the surfaces to which they will be assigned.

Layer Visibility (Editor)

Available in: **Matter: Editors** > **Layer Visibility**

Layer Visibility is a control panel for the visibility of geometry and lighting layers, as well as lighting layer colors. These types of layers are managed directly in the **Shaper** sidebar, without the help of a dedicated editor. **Layer Visibility** affords an overview of the hierarchy of layers and provides controls over their visibility in **Matter**.

The editor is organized into two tabs: **Geometry** and **Illumination**. The layer hierarchy is displayed in the corresponding tab. Next to each layer's name, an icon indicates the layer's current state:  visible or  hidden. An illumination layer's color sets are indicated as enabled or disabled in the same manner as in the **Shaper** sidebar tab.

The visibility of lighting layers is a viewport-level property. When the first viewport is opened, the visibility state is initialized with the state set in **Shaper**. From then on, modifications made in **Layer Visibility** are applied both to the active viewport and to the visibility state saved in **Shaper**. When additional viewports are opened, the last saved state in **Shaper** is used.

Modifying a Layer's Visibility

Modifying a layer's visibility changes what is shown in the active viewport.

Modify the visibility state of a layer in the **Layer Visibility Editor**:

- To modify the visibility state of a geometry layer, click on the **Geometry** tab. Find the layer you would like to modify, then click on the icon representing that layer's current visibility state.
- To modify the visibility state of a lighting layer, click on the **Illumination** tab. Find the layer you would like to modify, then click on the icon representing that layer's current visibility state.

This switches the visibility state. If the layer was hidden, it will now be visible. If it was visible, it will now be hidden.

The visibility state icon will change to reflect the new state.

Modifying the Intensity and the Color of an Illumination Layer

Color and intensity of lighting layers are model-level properties. Modifying the intensity or the color of a lighting layer will have an effect on all of the viewports displaying the model.

In the **Illumination** tab, find the layer you want to modify. Click on the color or intensity of the illumination layer to change the value.

Modifications are made in real time.

PLUG-INS

HDR Light Studio Plug-In

Available in: **Matter**: sidebar environment library >  **Create environment with HDR Light Studio**



NOTE



To use HDR Light Studio plug-in, you have to directly purchase the Automotive version of Lightmap HDR Light Studio from the Lightmap website.

Link to the product: <https://www.lightmap.co.uk/>

To gain access to the functions of HDR Light Studio, click the  **Create environment with HDR Light Studio** in the sidebar **Environments** library.

Patchwork 3D creates a new HDRI environment of the "live" type as soon as the plug-in is launched.

Several lighting environments are available:

-  **HDR Light Studio LightPaint Illumination**: in Patchwork 3D, click on the point of a surface you want to illuminate. The light selected in HDR Light Studio is repositioned in the environment so as to illuminate this point. The light is positioned along the normal to the surface at this point in order to obtain a maximum intensity where desired.
-  **HDR Light Studio LightPaint Reflection**: in Patchwork 3D, click on the point of a surface on which you want the reflection of the light source selected in HDR Light Studio to be displayed. The light source is repositioned in the environment so as to be reflected on this point. The angle between the new light direction and the normal to the surface at the selected point equals the angle between the observation direction and this same normal.
-  **HDR Light Studio LightPaint Rim**: in Patchwork 3D, click on the point of a geometry surface on which you want the rim light to appear in HDR Light Studio. This light exposes the contour or edge of the geometry to light. This highlights the contours of the geometry to accentuate its silhouette and curves. It can also be used to separate the geometry from the background.



TIP

To manipulate the HDRI parameters and see the effects in the Patchwork 3D viewport, simply assign this environment to your scene by a simple drag and drop.

Lights created in HDR Light Studio are instantly visible in viewport.

Patchwork 3D makes it possible to create several HDR Light Studio environments. To call up the plug-in window for an environment, simply click the  **Edit environment with HDR Light Studio** button in the environments window.

The  **HDR** button located at the bottom left of the HDRLS interface allows you to save the HDR image in high resolution on your hard drive. You can also display the Patchwork 3D preview window in HDRLS. From the menu, click on **Window** and **Render View** which is at the bottom of it.

When the high-definition environment image is saved, it is automatically sent to Patchwork 3D. To benefit from the high-definition quality of the saved environment, simply increase the resolution of the environment for the reflection and/or for the background. These parameters can be accessed by Product > **Environment properties**.

The  **High-quality environment** button in the Matter sidebar's environment library lets you increase the quality of the HDRI environment sent to Patchwork 3D by the plug-in.

This button calls up the same action as the **HDR** button at the bottom left of the HDRLS interface. It lets you save the HDR image in high resolution on the workstation's hard drive.



TIP

If you edit your existing lighting setup in HDR Light Studio, your HDR is sent to Patchwork 3D as a low-definition environment. When your environment changes are finished, remember to save your HDR environment again to your disk (**HDR** button) so that it will be sent to Patchwork 3D.



NOTE

For additional information concerning HDR Light Studio uses see online help or PDF User Guide at <https://www.lightmap.co.uk/support/>.

IMPORT AND EXPORT

Importing 3D CAD Models

In the **Shaper** interface, CAD models are imported using the menu **Model > Import** or **File > Import in a new database**. To import a model, select the desired file format, and then select your file using the browser. A status bar will appear, indicating the progress of this import.

The following file formats are available:

FBX (*.fbx)	STEP (*.step / *.stp)
DXF (*.dxf)	Creo, PRO Engineer (*.prt / *.asm)
Wavefront OBJ (*.obj)	Catia V4 (*.model / *.exp)
3DS (*.3ds)	Catia V5 (*.CATPart. / *.CATProduct)
STL (*.stl / *.sta)	CATProduct V2 (*.CATProduct)
Parasolid (*.x_t / *.x_b)	Wire file
Parasolid IGES (*.iges / *.igs)	Wire folder
Solid Edge (Assembly= *.asm) / (Part= *.par)	NX (*.prt)
SAT (*.sat / *.sab)	SolidWorks (Assembly= *.sldasm) / (Part=*.sldprt)
XML (*.xml)	Lumiscaphe P3DXml (*.xml)

The import compatibilities in 2026 X8 are as follows:

Source	Format	Support in Patchwork 3D
3D XML	.3dxml	From 4.0 up to 4.3
Autocad DXF	.dxf	Up to 2026
Siemens NX	.prt	From 11 up to NX 2512
Siemens NX Direct 5	.prt	From NX up to NX 2406
SolidWorks	.sldasm, .sldprt	From 98 up to 2026
Autodesk Maya	.fbx	Up to 2020.3
Autodesk 3ds Max	.fbx	Up to 2020.3
Acis	.sat	R1 - 2022 1.0
Parasolid	.x_t, .x_b	Up to 38.1
Alias	.Wire	Up to 2026
SolidEdge	.asm, .par, .psm, .x_t	From V18 up to SE 2022 (with Parasolid export)
Creo Pro/Engineer	.asm, .asm.*, .prt, .prt.*	From PRO/E Release 16 up to Creo 12.0
Catia V4	.model, .exp	From 4.1.9 up to 4.2.4
Catia V5	.CATPart, .CATProduct	From V5 R8 up to V5-6 R2024
Catia V6	.CATPart, .CATProduct	Up to V6 R2024

Source	Format	Support in Patchwork 3D
OBJ	.obj	All versions
STL	.stl	All versions
3DS	.3ds	All versions
Step	.stp, .step, .stpZ, .stpx	AP203, AP214, AP242 versions
IFC	.ifc, .ifczip	IFC2x3, IFC4
IGES	.iges, .igs	Up to 5.3

Based on the format of the file you would like to import, it is recommended to use the first possible line in the following table:

From	To	Importer to Use
Catia, Acis, NX, SolidWorks, Parasolid, software supporting FBX	Patchwork 3D	Direct interoperability (for example, use the NX importer for NX files)
software supporting STEP	Patchwork 3D	STEP
software supporting IGES	Patchwork 3D	IGES
software supporting OBJ	Patchwork 3D	OBJ
any other software	Patchwork 3D	DXF, STL

Patchwork 3D uses two 3D modeling engines to import file formats storing geometry elements as NURBS:

- ACIS
- Parasolid

Formats imported using these powerful geometry engines will allow users to work directly with the surface topology. Tessellation and assembly options are available for surfaces imported in these formats.

Autocad DXF, Wavefront OBJ, Ksc formats store the models as lattice mesh geometry. Tessellation and assembly options are not available for surfaces imported in these formats.

Patchwork 3D works on a metric scale. Certain CAD formats specify the scale used for the design of models. In this case, Patchwork 3D interprets this information and converts the dimensions of the model from the original scale to the metric scale. When the scale information is not available in the CAD file, Patchwork 3D uses the default scale specified for each format in the general preferences of the software.

To open the window used to set the application's importers default units, navigate to the **File** menu > **Settings** > **Geometry** tab > **Define default units** button.

Import User Interface

The import parameters are accessible from **Shaper** > **Model** > **Import a CAD model** and from **File** > **Import in a new database**.

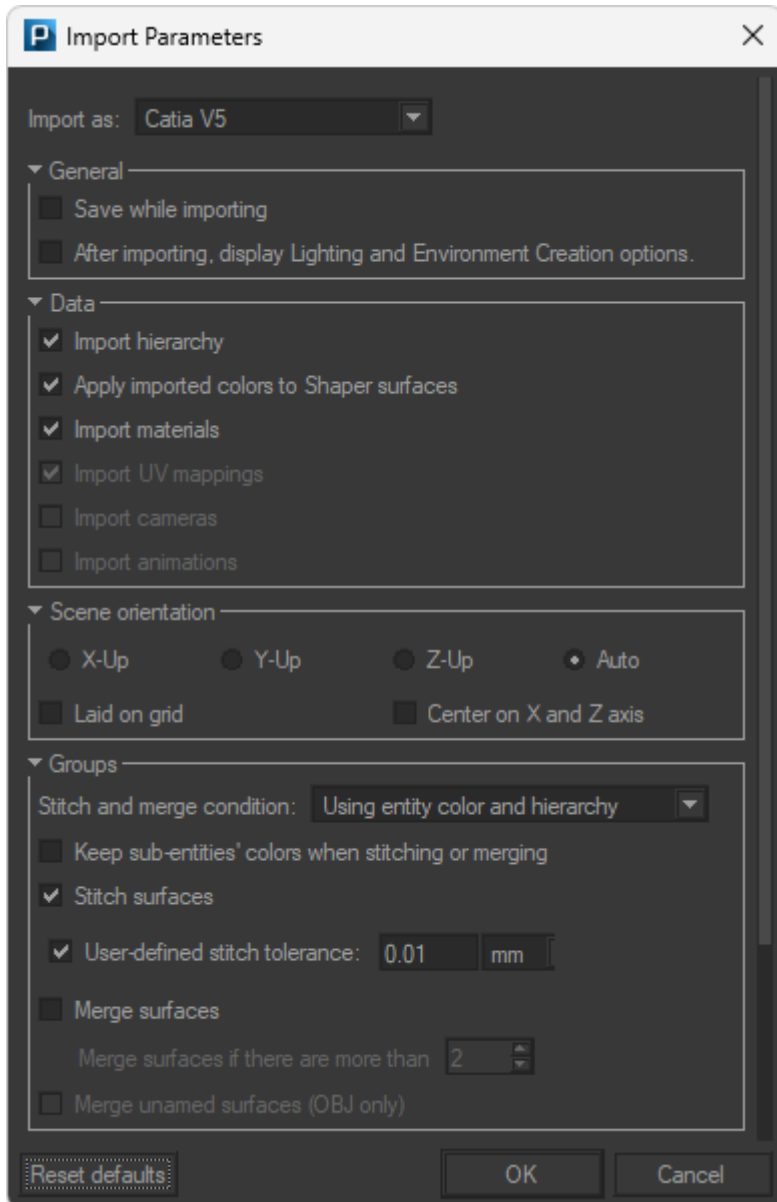

Import Parameters dialog box for a CATPart file

Depending on the FBX file you wish to import, the following options will be available:

General

If the **Save while importing** checkbox is ticked, Patchwork 3D will first ask you:

- to save your CAD model import in a P3D file format that can be interpreted by Patchwork 3D,
- whether or not to save the rendering cache (for more details please refer to the following chapter: [Data \[42\]](#)).



NOTE

Save while importing allows you to save the P3D file at regular intervals to avoid saturating the memory when the CAD model being imported is large. Please note that this option has an impact on the import time.

If the **After importing, display Lighting and Environment Creation options** checkbox has been ticked, at the end of the import, the **Scene parameters** window is displayed, so that you can select the elements constituting the creation of a scene, that is to say, its lighting and its environment. Details of the available options can be found below in the section [Automatic scene preparation \[250\]](#)

Data

You can choose the following options to import an FBX file:

- [hierarchy \[258\]](#)
- **colors**
- [materials \[256\]](#)
- [UV mapping \[256\]](#)
- **cameras**
- [animations \[257\]](#)

Scene orientation

The scene orientation may differ in Patchwork 3D depending on the CAD software with which the scene was created. Patchwork 3D helps you fix this.

Choose here the scene orientation of the original file.

- **X-Up**
- **Y-Up**
- **Z-Up**
- **Auto**, if available for the file format.

In addition to the orientation of the scene, you also have the possibility of choosing the location of the imported surfaces with the following options:

- **Laid on grid**
- **Center on X and Z axis**

Groups



NOTE

Group options are only available for Nurbs formats.



NOTICE

By default, the **Keep sub-entities' colors when stitching or merging** option is not selected during import, and Patchwork 3D will generate a single surface.

Select the **Keep sub-entities' colors when stitching or merging** option to reproduce, upon import, the assemblies and parts of the original model with their respective color.

This option is only functional if the **Stitch surfaces** or **Merge surfaces** is checked.

Choose here whether or not to join the surfaces together by checking the **Stitch surfaces** checkbox.

The **User-defined stitch tolerance** option allows you to personalize the stitch tolerance criteria. By default, the setting is calculated automatically depending on the size of geometry (unchecked box). On the contrary, when the option is checked it allows you to define the threshold (distance) from which the surfaces will be joined.

The **Merge surfaces** option creates a single surface from a user-defined threshold.

With certain objects, this automatic calculation may not produce the desired stitched result; thus, by checking this box, you can specify a tolerance in the unit of your choice, which is fixed and not dependent on the size of the objects.

Tessellation



NOTE

Tessellation options are only available for Nurbs formats.

Patchwork 3D uses a powerful geometry engine that enables it to preserve the geometrical information of each surface.

Surface and **Normal** parameters will allow you to adjust the tessellation finesse when importing.

Animations



NOTE

The animation options are only available for FBX file format.

Import to timeline with user-provided name checkbox lets you replace the original name of the animation on your own.

Simplify animated meshes if needed simplifies the animation as explained in [Timelines \[449\]](#) paragraph.

Animated meshes box allows you to import FBX animation with two different modes.

- **Basic mode:** The animation will be imported as a standard channel animation in your timeline.
- **Advanced mode:** The animation will be imported as an advanced channel animation in your timeline.

Node curve box allows you to select between two different options if you want to edit or not the animation curve.

- **Import curve** option will convert to an editable format by Patchwork 3D which allows later on the edition of the curve.
- **Bake animation** option will import the animation curve without the possibility to edit it.

Advanced options

You can record the import steps in a log file of your choice with the option **Activate the log** or define the **P3D Xml settings** for the formats concerned and the **Specific settings** to the data format.

When importing an FBX file that contains materials, Patchwork 3D allows you to choose between importing materials into an existing product with the option **Merge products aspects to current products** or add the materials to a new product with the option **Create new products**.

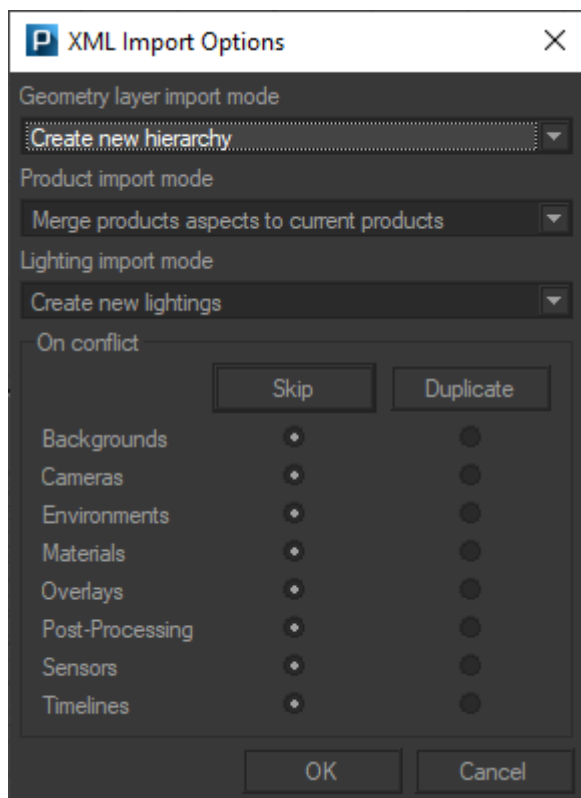

Automatic scene preparation

If the box **After the import, display the lighting and environment creation options** has been checked, at the end of the import, the following window is displayed.

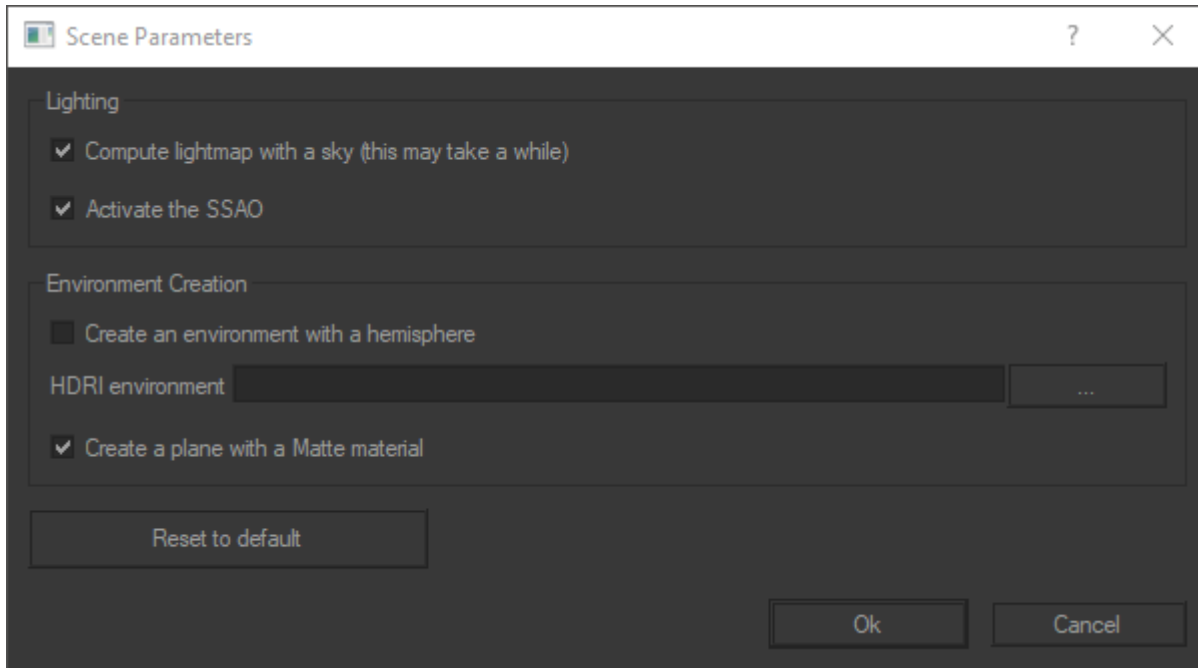

Check the desired options and Patchwork 3D takes care of the rest to create the scene with its lighting and environment.

The option **Create an environment with a hemisphere** is particularly useful if you want your model to be quickly staged in a very realistic environment. Patchwork 3D will take care of creating for you a hemisphere, an environment, and an [environment material \[341\]](#). The latter will be automatically assigned to the surface of the hemisphere. The HDRi environment files recognized by Patchwork 3D are HDR and EXR. You can also add a plane with the shadow of the imported model to your scene (cf. [Matte material \[345\]](#)).



TIP

If you do not select an HDRi environment, Patchwork 3D will automatically apply the **Studio** environment on the surface of the hemisphere.

Import Options

The table below lists the available options (✓) depending on the import formats.

Internal geometry format	Options		Data				
	Format	Save while importing	Import Colors	Import Materials	Import UV	Import Cameras	Import Hierarchy
ACIS Nurbs	Acis xml	✓	✓	✓			✓
	Acis sat	✓	✓	✓			✓
	Catia V4	✓	✓	✓			✓
	Catia V5	✓	✓	✓			✓

Internal geometry format	Options		Data				
	Format	Save while importing	Import Colors	Import Materials	Import UV	Import Cameras	Import Hierarchy
	IGES	✓	✓	✓			✓
	NX	✓	✓	✓			✓
	Pro/E	✓	✓	✓			✓
	SolidWorks	✓	✓	✓			✓
	Step	✓	✓	✓			✓
Parasolid Nurbs	Parasolid	✓					✓
	Solid Edge asm/prt	✓					✓
	Wire	✓					✓
Mesh	3ds	✓					
	Obj	✓					
	STL	✓					
	FBX	✓					
	DXF	✓					
	LWO	✓					

Internal geometry format	Options		Groups			Scene Orientation	Tessellation
	Format	Stitch	Merge	Merge unamed			
ACIS Nurbs	Acis xml	✓	✓		✓	✓	
	Acis sat	✓	✓		✓	✓	
	Catia V4	✓	✓		✓	✓	
	Catia V5	✓	✓		✓	✓	
	IGES	✓	✓		✓	✓	
	NX	✓	✓		✓	✓	
	Pro/E	✓	✓		✓	✓	
	SolidWorks	✓	✓		✓	✓	
	Step	✓	✓		✓	✓	
Parasolid Nurbs	Parasolid	✓	✓				
	Solid Edge asm/prt	✓					
	Wire	✓	✓				
Mesh	3ds						
	Obj			✓			
	STL						

	Options	Groups				
Internal geometry format	Format	Stitch	Merge	Merge unamed	Scene Orientation	Tessellation
	FBX					
	DXF					
	LWO					

	Options	Advanced Options		
Internal geometry format	Format	Log	P3D Xml Settings	Specific Options
ACIS Nurbs	Acis xml	✓		
	Acis sat	✓		
	Catia V4	✓	✓	✓
	Catia V5	✓	✓	✓
	IGES	✓	✓	✓
	NX	✓	✓	✓
	Pro/E	✓	✓	✓
	SolidWorks	✓	✓	✓
	Step	✓	✓	✓
Parasolid Nurbs	Parasolid	✓	✓	✓
	Solid Edge asm/prt			
	Wire			
Mesh	3ds			
	Obj			
	STL			
	FBX		✓	✓
	DXF			
	LWO			

Exporting CAD models

In *Shaper*, CAD models are exported using the menu option **Model > Export** or **File menu > Export**. To export a model, select the desired file format, then enter the filename you would like to save the model under.

The following file formats are available:

- Lumiscaphe Ksc (*.ksc) (optional, based on your license)
- Wavefront OBJ (*.obj)
- Lumiscaphe P3DXml (*.xml)
- FBX (*.fbx)

The following table gives the version compatibilities:

Format	Compatible versions
OBJ	All versions
P3DXml	P3D software suite 2026 X8
FBX	Autodesk Maya / Autodesk 3ds Max from 2013

P3DXml Format

This format is for exporting and importing P3D data in XML format via the **Shaper** module of Patchwork 3D.

It is used mainly for merging several elements from different P3D databases (e.g. vehicle interior and exterior).

List of transferred elements:

- Layers,
- Surfaces and their geometries (nurbs, meshes),
- UV coordinates,
- Lighting effects,
- Kinematic hierarchy (All of the work done to prepare a synchronized animation of surfaces is preserved during the export.),
- Configurations,
- Materials,
- Environments, including alternate background textures,
- Timelines,
- Camera hierarchy,
- Sensors.

The **P3DXml** format is an open format and facilitates the creation of customized gateways between Patchwork 3D and the other software.

FBX Import

The FBX import allows information related to surfaces and surface parameterization, textures, camera animation paths, and materials to be imported.

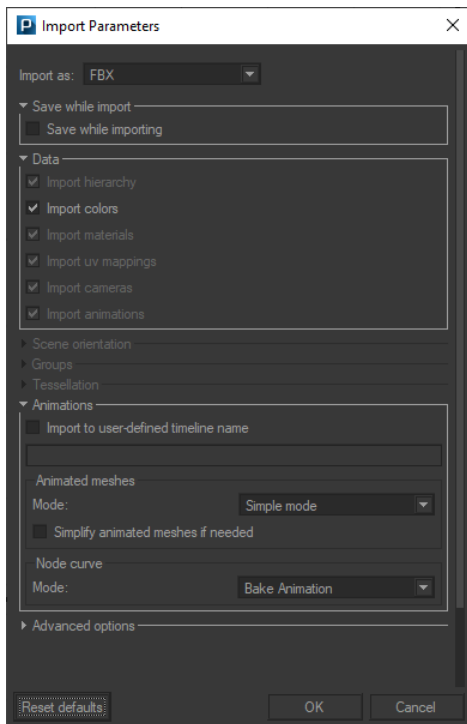

Import Parameters dialog box for an FBX file

During the import process of one or more FBX files, a log window displays its progression. The log window shows events, warnings (printed in orange), and errors (printed in red).

Imported FBX Data

Surfaces

The Patchwork 3D FBX importer only supports FBX mesh surfaces. If the FBX surface contains quadrangles or polygons which have more than four vertices, they are triangulated.

If the FBX file contains NURBS or Patch nodes, the importer carries out a preprocessing step in order to triangulate these geometries using the FBX SDK. After this preprocessing step, these surfaces are imported as **Shaper** mesh surfaces. The FBX importer does not try to stitch surfaces automatically.

If the surface contains more than one material, it is split into sub-surfaces. Each sub-surface corresponds to the restriction of the original surface to one material. In this case, a null surface is created and serves as a parent for the sub-surfaces.

Point cache

If references to point cache files containing information for vertex displacement are found in the FBX file, the animation of the meshes are imported at the same time as the surfaces.

Point cache files are exported from Autodesk Maya or Autodesk 3ds Max during the FBX export. This plugin is included in both Autodesk Maya 2017 and Autodesk 3ds Max 2017. The **Geometry Cache File(s)** option (Autodesk Maya) or the **Point Cache File(s)** option (Autodesk 3ds Max) must be selected.

The MC (XML) format is preferred. Point cache files in pc2 or MC (XML) format are supported.

Example: exporting from Autodesk 3ds Max 2017

1. Create an object with a mesh animation.
2. Select the menu option **Edit > Manage Selection Sets**. The named selection set management window will open.
3. Select the object with a mesh animation, then create a new selection set. This new set contains the animated mesh.
4. Select the option from the main menu **> Export > Export**. Choose the **FBX** export and confirm. You will need to provide a filename and a location to save the export.
5. An options window opens. Expand the **Animation** section. Check the box beside the **Animation** option.
6. Expand the **Cache Point File** section. Check the box beside the **Cache Point File(s)** option. Then, in the drop-down list, choose the selection set you created for the animated mesh.
7. Validate. This operation will create an FBX file with the vertex displacement information. It also creates a folder with the same name and the **_FPC** suffix, containing an MC file and an XML file. These are the point cache.

If you prefer, you can modify the type of point cache file to be created:

1. Create an object with a mesh animation.
2. In the sidebar, select the **Modify** group.
3. Select the mesh.
4. Add a modifier by selecting **Point Cache** from the **List of Modifiers**.
5. In the **Parameters** zone, click on **New**. At this point, you can select the file format: **XML** (the default format) or **PC2**. Validate your choice.

When exporting an FBX file with point cache files as described above, the selected point cache format will be respected.

For additional information on creating animated meshes and their properties, refer to the Autodesk Maya documentation under the **Geometry Cache** section, or to the Autodesk 3ds Max documentation under the sections **Modifiers**, **Point Cache Modifier (Object Space)** or **Point Cache Files**.

Surface Parameterization

The Patchwork 3D FBX importer supports the import of the FBX UV sets, which are copied automatically into the fields **uvw:0**, **uvw:1...** of the Patchwork 3D surfaces. For each of these UV sets, the surface mapping type is set to **Extract**.

Materials

The Patchwork 3D FBX importer also imports some of the materials used on mesh surfaces. The imported materials are assigned to the imported surfaces.

Lambert and Phong materials can be imported. The imported properties are the following:

- Diffuse color,
- Ambient color,
- Opacity modulator,
- Reflection Factor (for Phong materials),
- Specular color and factor (for Phong materials).

The following figure shows the expected behavior when importing a FBX file created using Maya software (note: the lighting is different between the two screenshots).

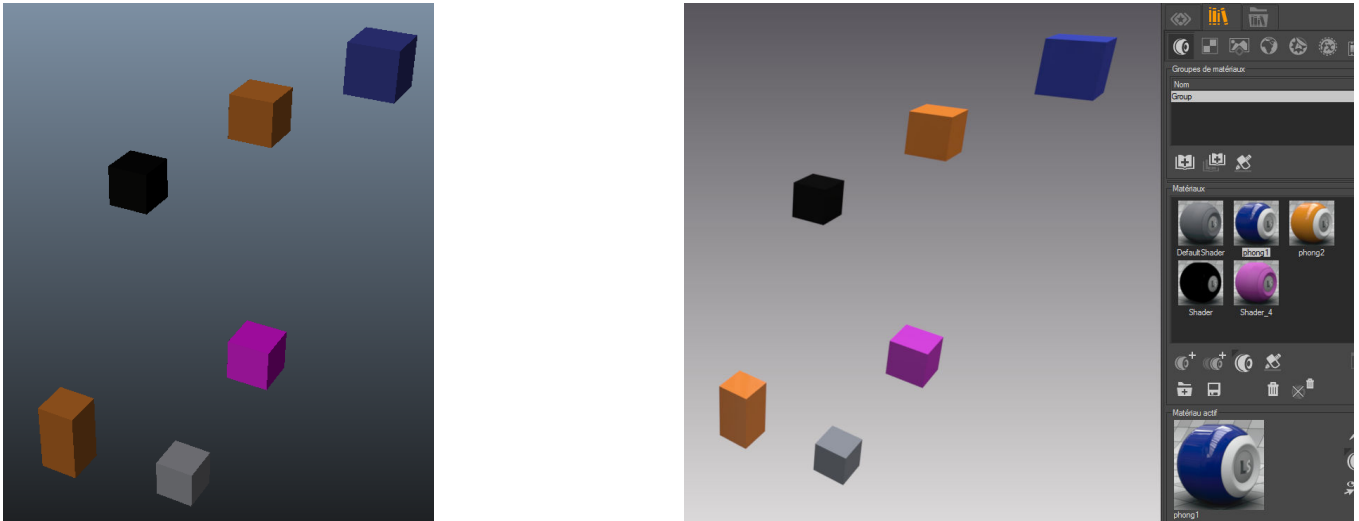

Maya shading (left) and Matter shading (right) for an imported FBX file.

Textures

If a texture file is found on the diffuse, bump or specular layer of a Lambert or Phong material, it is imported provided the FBX importer is able to retrieve it. Only the first texture file on each layer can be imported. If more than one texture file is found on a given layer of a FBX material, all files starting from the second one are ignored. In such cases, a warning is inserted in the log file.

The Patchwork 3D FBX importer looks for texture files as follows: it tries to retrieve the file using the absolute file name found in the FBX file first, and then using the relative file name generated by the FBX export module. Lastly, it tries to retrieve the file in the FBX file directory using only the texture file name.

The texture is assigned to the corresponding layer of the material, and is also visible in the **Texture** tab of **Matter**.

Camera Animation Path

The Patchwork 3D FBX importer imports camera paths as follows: each key frame is imported as a tuple (from, to, up, fov) written in a Patchwork 3D Kam file. Thus, baking the animation at the desired frame rate while exporting a FBX file is necessary as intermediate positions cannot be rebuilt from Kam files.

The FBX importer creates one Kam file per camera. The Kam file name is built as follows: "**fbx_file_name**> **FBX import** – **camera_name**>".

Animation

Transformations of the scene graph saved in FBX format are imported as a timeline containing channel animations. Each channel animation corresponds to the animation of a node in the FBX scene graph and is placed at the correct time in the timeline.

As channel animations, these elements appear in the **Channel Animations** library in the **Timelines** editor and can be reused in other timelines. Channel animations created by the FBX importer are not editable.

The FBX importer creates the following elements:

- A timeline with the name of the imported FBX file. This timeline is shared with imported animated meshes.
- One channel animation per node animation, each with the name of the corresponding node.

Other FBX Nodes

Any other FBX nodes are imported as null surfaces. The null surface name in Patchwork 3D is the node name read in the FBX file.

Visibility Layer Hierarchy

The FBX importer first creates a layer with the time stamp and the path to the directory used to store the temporary files generated during the import process. Then, it creates a layer for each imported file using the file name as layer name.

For each file, the FBX importer builds a layer hierarchy corresponding to the FBX file node hierarchy.

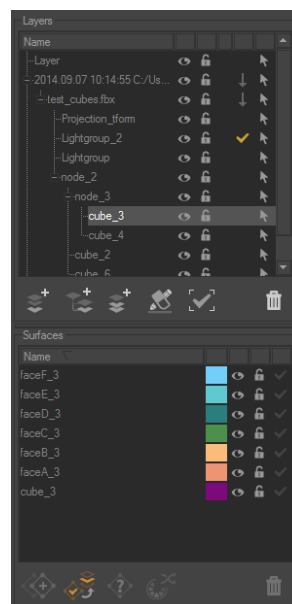
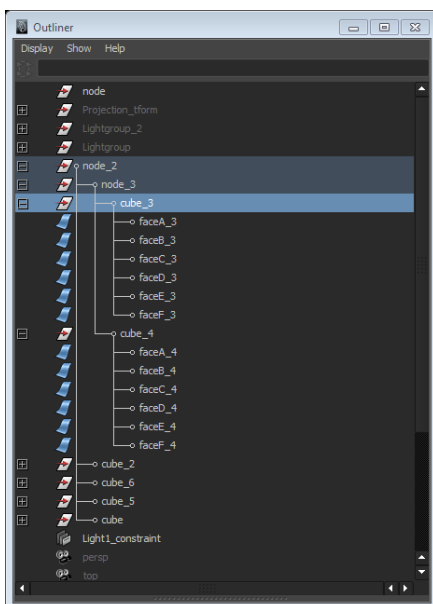

Layer hierarchy from data in the FBX format in Maya (left) and Patchwork 3D (right).

Kinematic Hierarchy

The FBX importer also builds a kinematic hierarchy that follows the FBX node hierarchy.

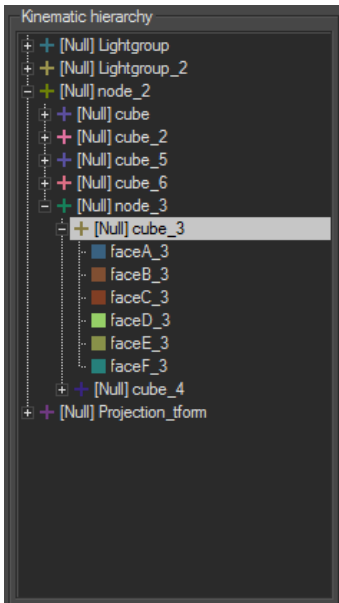

Example of kinematic hierarchy in Shaper built according to a FBX node hierarchy.

Wire Import

Importing Files in the Wire Format

Geometry Data

The different types of geometry data interpreted are:

- Groups,
- Meshes,
- Polysets,
- Shells,
- Surfaces.

Existing parameterizations are not interpreted. As a result, imported surfaces are given the default parameterization (type BOX).

Material Data

The material data interpreted are:

- "File" type textures,
- RGB color parameters,
- Some parameters from the Phong and Lambert models.

For each Surface or Shell, the first shader only is retrieved. A **Matter** material is created from this shader and assigned to the corresponding object.

A standard **Matter** material is created by retrieving color data. Furthermore:

- For "Phong" materials, intensity and specular roughness data, along with the diffuse intensity, specular filter and transparency, are retrieved,
- If it is a "Lambert" type material, the diffuse intensity is recovered.

"File" textures in the original material are added to the texture library, and the first one is assigned to the diffuse color map of the material.

Wire File Format Import Options

All options for importing Wire files or folders are gathered in a dedicated dialog box. This dialog box is accessed from **Shaper** either by selecting **Model > Advanced > Wire folder**, or from the **Model** tab.

Surfaces

This dialog box contains the options for importing surfaces.

Visual quality : the tessellation size may be set using either the slider or the field linked to it. By default, the tessellation is generated with a Tolerance of 0.5 mm between the triangulated surface and the NURBS surface.

Grouping surfaces: three options are available for grouping surfaces.

- **By Layer**: A **Shaper** layer is created for each Wire layer. Groups of imported surfaces are assigned to the **Shaper** layer associated to their initial Wire layer. The groups are made up as follows: for a given Wire group containing at least one Shell or Surface, a **Shaper** group is created with the surfaces it contains. This option is activated by default.
- **By shader**: A **Shaper** visibility layer is created for each Wire shader. The groups are created similarly to when using the By Layer option.
- **By Layer Hierarchy**: A **Shaper** visibility layer hierarchy that reproduces the Wire layer/group hierarchy is created.

Transformation: this option is for defining how surfaces with symmetry are imported.

- **No symmetry**: no symmetry is imported.
- **Use layer symmetry**: the symmetry defined in the layers of the Wire file is used (the plane of symmetry is retrieved). This option is activated by default.
- **No symmetry on shaders with suffix**: a symmetry with the default plane (equation $z = 0$) is used for all surfaces whose shader does not have a name including the specified suffix.

Kinematics: this option allows importing object graphs as kinematics graphs. A null surface is attached for each group of the Wire data tree. The null surfaces are attached to a visibility layer named **Wire Import Kinematics** and the kinematics hierarchy is accessible in the dedicated tab. This option is enabled by default.

Topology: these options control the sewing process and grouping the surfaces.

- If **Use topology** is activated, then an attempt at converting Shells into Parasolid surfaces is made. Shells may be imported as meshes if the option **Convert to mesh** in the **Topology conversion failures** box is enabled. These meshes are built using the Alias tessellation engine.
- **Autostitch** is for controlling the attempts at sewing imported surfaces. If Autostitch is enabled, then an attempt is made to:
 - sew the surfaces of a Shell together,
 - sew the surfaces of a group of objects with the same shader,
 - sew the various parts in a list of Shells.

The options **Use topology** and **Autostitch** are enabled by default.

Camera

This option imports the file's cameras as cameras. These cameras are saved in a group of cameras named **wire import – filename**. This option is activated by default.

Shaders

The options for importing textures and materials are contained in this box.

Import textures: this option allows you to import textures of the "file" type, possibly specifying a maximum size. It is activated by default.

Reuse shader information: if a material with the same name already exists in **Matter** library, then it is used. Otherwise, this option allows the material library to:

- Create a new material systematically (**No**),
- Create a new material only if there is no material with the same name in the default library (**Use default library**),
- Create a new material if there is no material with the same name in the specified library (**Use specified library**).

Topology Conversion Failures

This box is for defining the actions to perform in case of a topology conversion failure.

Save failed objects: this option is for saving Shells that could not be imported as files, using Alias file format. It is disabled by default.

Convert to mesh: this option converts Shells whose import failed using Alias tessellation engine into meshes. It is disabled by default.

Log

A log file can be specified using this option. This file may be deleted if no problem occurred during the import by selecting Delete if everything went OK. No default file is specified.

Update Mode

Update current model with imported file: when this option is enabled, the **Shaper** existing surfaces of the current model with the same name as surfaces of the imported file are updated. The geometry,

comment, symmetry and material are updated. If a group of surfaces with the same name exists, its color and material are updated, and the new surfaces attached to it.

The group name is defined as follows:

- For a Shell, it is the name of the Wire Shell node,
- For a list of Shells, it is the name of the Group and the shader name linked with #.

Keep textures: when this option is enabled, updates of a surface or a group of surfaces do not take the material into account.

Common settings

Save after each file: When performing a batch import of a folder containing multiple files, this option enables the model to be saved at the end of each file's processing rather than only after the entire batch is complete. This ensures that any work that has already been imported is preserved on the disk as the process progresses.

In the event of an unexpected interruption during processing (crash, interruption, error on a file), any models that have already been imported and saved will be retained. This feature prevents the need to restart the entire batch. However, it's important to note that this option may increase the total import time due to more frequent disk writes, and it is not enabled by default.

Exporting Matter Products

Matter products can be exported via the menu **Product > Export**.

Export KDR

Accessible in: **Matter: Product > Export**

In order to be used with the Lumiscaphe software suite of 3D visualization tools, the raw authoring data must be exported as a Digital Aspect Mockup (DAM) in the format KDR. This format contains only the data required by the rendering engine in order to display the product variants and configurations created in Patchwork 3D. The image underlying the relief in texture is no longer present; only the resulting calculations needed to display a material using that texture are conserved. Consequently, authoring is not supported in this format. The KDR is optimized to load more quickly: unlike the .p3d format, in which the displayed images must be calculated when the file is opened, the data in the KDR can be transmitted directly to the graphics card without further treatment.

The Digital Aspect Mockup may then be used as-is in any of the Lumiscaphe visualization solutions.

Depending on the case, the addition of new features in Patchwork 3D has an impact on the data to be exported in KDR format. To clearly identify which KDR format works with the version of Patchwork 3D, *X i* has been added in the software naming.

- If adding the features in Patchwork 3D do not modify the KDR format, we could have the following examples: Patchwork 3D 8.3 **X2**, Patchwork 3D 8.4 **X2**, Patchwork 3D 8.5 **X2** , and so on.
- However, if adding the features in Patchwork 3D modify the KDR format, we could have the following examples: Patchwork 3D 8.3 **X2**, Patchwork 3D 8.4 **X3**, Patchwork 3D 8.5 **X4** , and so on.

When exporting a product in KDR format you will have the ability to export:

- The current version of KDR: **KDR**. In the **Export to KDR Xn** window that appears, type the file name under which you want to save it.
- The previous version of the KDR: **KDR (previous version)**. In the **Export to KDR** window that shows up, select the version of the KDR you want to export from the drop-down menu. Then type the file name under which you want to save it.



NOTICE

A lower version means better compatibility with other software, but fewer features supported. A higher version means more features supported, but the compatibility with other software might be broken.

The table below lists the supported format(s) according to software versions.

KDR	Version	Description
X8	2025 and greater versions	Use of the new parameters in the Environment Material to choose the lighting behavior of the material. Use of the new Resolution offset parameter in materials to reduce Moiré effects due to high-frequency textures.
X7	2024 and greater versions	Use of new generation mirror material (Diffuse/Reflection/Bump). Use of animated textures as bump. Support of the Override repeat applied as a sticker parameter in Standard materials.
X6	2023	Support of camera lens shifting. Use of Nulls as a target for camera animation bookmarks.
X5	2021.1 and 2022	Recolouring of AxF CarPaint (CPA2) materials. SSAO Cameras exposure property addition in configurators.
X4	From 2019.2 to 2020.2	AxF CarPaint (CPA2) materials. Choice of units for overlays and post-processes.
X3	2019.1	Using the roughness map.
X2	v8.3	U or V repetition for stickers and textures. Repetition for labels and textures in mirror.
X1	From v8.0 to v8.2	"Software Suite v8.0"

Export FBX

Accessible two different ways from:

- **Matter : Product > Export**
- **File > Export > FBX**

To export an FBX product, select the FBX file format, an **FBX Export Options** window shows up, select the desired settings and click on **Export** button and then type the name of the file under which you want to save it.

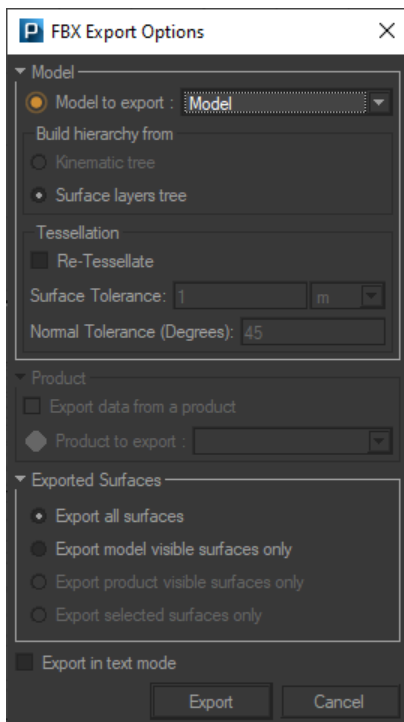

If your product has kinematics you can choose to export the **Kinematic tree** (the option is enabled by default). Otherwise, only the option to export the **Geometry layer tree** will be available.

If your product does not have kinematics, the **Geometry layer tree** option will be enabled by default.

The following file format is available:

Format	Compatible versions
FBX	FBX 2013







MODELS

The highest-level object handled by **Shaper** is the model. A model is a collection of geometric and null objects and their properties.

Several related models can be stored in the same database. **Shaper** functions as a model explorer: you select the model on which you wish to work, by means of the model selector.

Operations on Models

Operations concerning models can be found in the **Shaper Model** menu or in the **Shaper Geometry** sidebar tab:

Icon	Function
	Create a new model.
	Duplicate a model. During the duplication of a model, Patchwork 3D shares the geometrical elements constituting the surfaces of the model between the original and the duplicate models. This means that duplicating a model uses very little memory.
	Rename a model.
	Import a model.
	Export a model.
	Delete a model.

A 3D model can occupy a large amount of memory. A **Shaper** model is loaded into the memory only when it is to be edited. All the models loaded during your work session are held in the memory and are instantly available by means of a system of tabs located just below the top toolbar.

On the right, in the same bar as the tabs, the button  can be used to close the current model. You can also clear a mode from the memory by closing it by means of the **Model > Close** menu option.

SURFACES

The surfaces are the 3D geometrical elements used to construct the models. The surfaces are directly derived from importing the CAD models into Patchwork 3D. The surfaces are represented by a lattice of triangles (a mesh).

A surface may contain several non-contiguous geometrical elements. Dressing models in **Matter** is performed surface by surface.



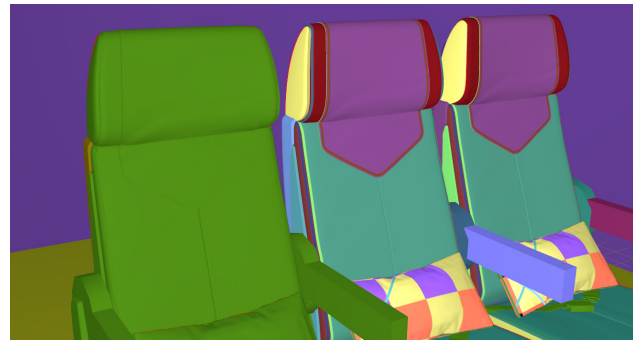
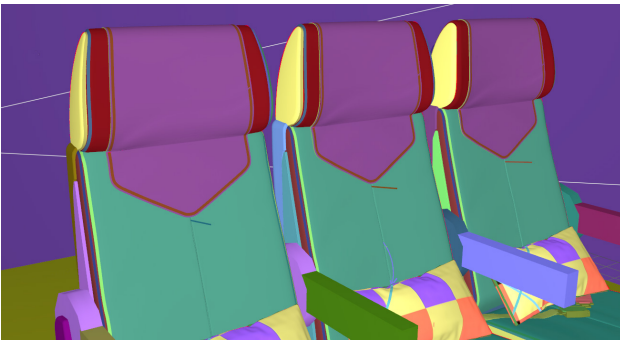

The same surface, whether it consists of one or more geometrical elements, can receive only one material. It is therefore important to split surface elements in your CAD tool before importing them into Patchwork 3D.







Left image: the seat on the left has several distinct surfaces. Right image: the seat on the left has a single surface made up of several geometric elements.

Operations on Surfaces

The operations associated with surfaces can be found in the menu **Surface** of **Shaper** or in the tab **Geometries** from the sidebar of **Shaper** :

Icon	Operation	Description
	Duplicate	Makes a copy of the selected surfaces in the active layer. The original surfaces are unselected and the duplicate surfaces are selected instead.
	Move	Moves all the selected surfaces into the active layer.
	Properties	Opens the Surface Properties (Shaper Editor) [218] .
	Randomize Surface Color	Changes randomly the color of the highlighted surface(s). For example, this allows the surfaces of geometry to stand out with different colors when you have imported a CAD file into Patchwork 3D.
	Delete	Deletes the selected surfaces.

Certain operations are available only from the **Surface** menu:

Icon	Operation	Description
	Duplicate with Symmetry	Duplicates a surface using a symmetry function. The duplicated surface is fully independent of the original, unlike the surface symmetry property, which can be activated in the Surface Properties. The surfaces duplicated in symmetry are highlighted.
	Copy	Copies the selected surfaces to the clipboard.
	Cut	Cuts the selected surfaces to the clipboard.
	Paste	Pastes the contents of the clipboard in the active layer.

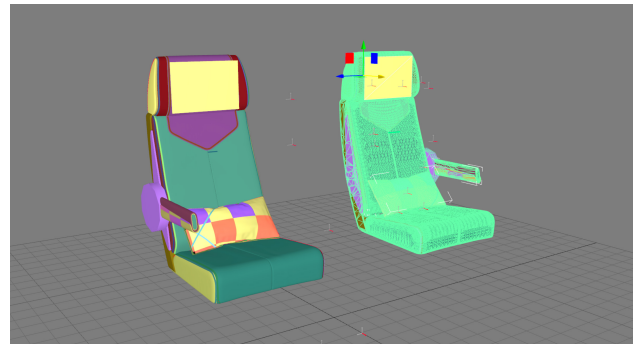
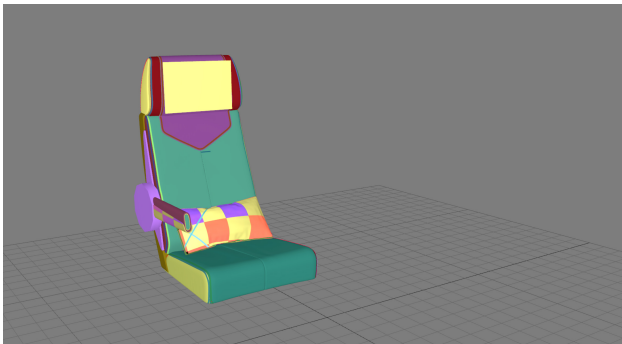

XY symmetrical duplication.

Surface Optimization

The optimization of surfaces is carried out in **Shaper**.

Surface optimization adds, corrects or perfects surface information after importing.

Triangulation

When a surface is derived from a parametric definition (for example, a NURBS), it is possible to modify its degree of tessellation, that is, the resolution of the triangular mesh that makes up the surface. This allows you to optimize the ratio of the rendering quality relative to the number of triangles generated.





Patchwork 3D will also tessellate groups of surfaces. Interactive tessellation is possible for the applicable surface, no matter what types of surfaces make up the mixed selection.



WARNING

Modifying triangulation requires particular license options. These functions are automatically available when a CAD import option is present.

Surface tessellation can be modified in **Shaper** using the toolbar buttons or the options in the **Surface > Triangulation** submenu:

Icon	Function	Description
	Increase Triangulation	Increases the tessellation of a surface by one degree (refine the surface by increasing the number of triangles).
	Decrease Triangulation	Reduces the tessellation of a surface by one degree.
	Set Triangulation	Sets and imposes a specific level of tessellation.
	Set Advanced Triangulation	Gives access to the advanced triangulation settings.

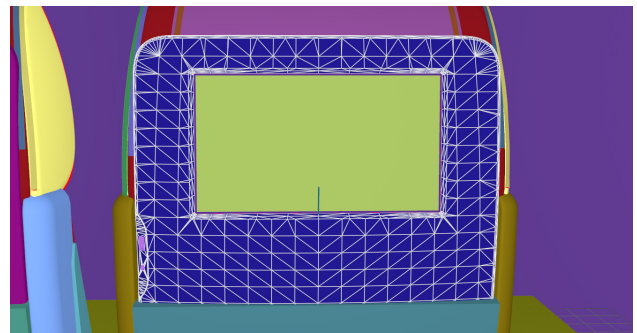
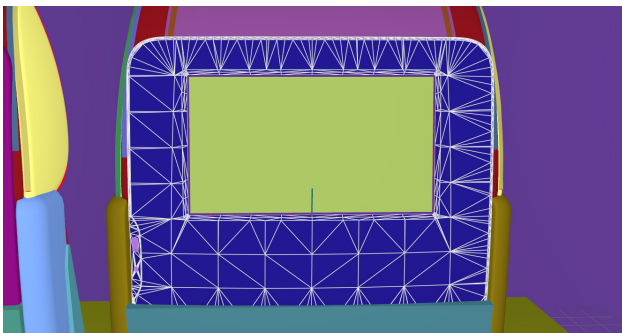



Modification of the tessellation parameter on a parametric surface.



Convert to Mesh: deletes the parametric representation of the selected surfaces. The current tessellation is permanently affected to the surface. This reduces the space taken up by surfaces in the database.

Stitch and Split Functions



In the menu **Surface > Surface Topology**:

Icon	Function	Description
	Stitch	Allows you to join ("stitch") or "weld" several selected surfaces.
	Split	Disassembles a surface composed of several geometric elements. Each geometric element becomes a surface in its own right.

Orientation: Front and Back Faces

A surface is an oriented geometric element with a front side and a rear side. By default, the back side of surfaces is not rendered. This procedure is called "backface culling". In **Shaper**, the rear sides not rendered are displayed in red.

Two visualization options are available in the **Viewport** menu:

Icon	Function	Description
	Track culling	Renders culled backfaces in red, making it possible to tell which faces aren't displayed. This option is enabled by default.
	Backface culling	Optimizes rendering by not calculating the back of surfaces, substantially accelerates the calculation of interactive 3D images. This option is enabled by default.

To use the backface culling correctly, the front face of the surfaces needs to be oriented to the visible side of the delimited volume. You can modify the orientation of the surface front and back faces from the **Surface** menu:



Reverse: reverses the orientation of the selected surfaces.

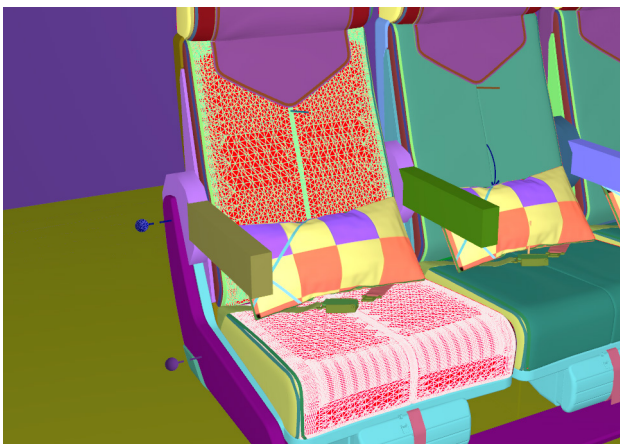

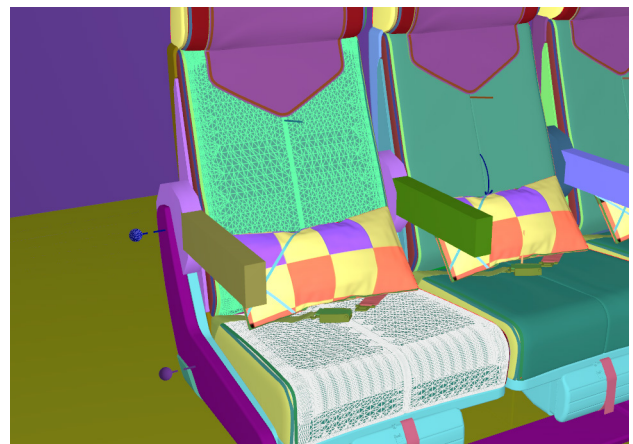

The incorrectly oriented surfaces are selected...



... and then inverted.

Surface Auto-Orientation

Three automatic orientation modes are available in the toolbar and from the **Surface > Auto-Orientation** menu:

Icon	Function
	Auto-orient visible surfaces
	Auto-orient selected surfaces
	Auto-orient surfaces towards interior



Visible Surfaces: automatically orients all surfaces visible from the current point of view. In order to determine if the front or the rear face of a surface is visible from this point of view, a rendering is performed. The number of red pixels is compared to the number of pixels of another color among the visible pixels of the surface (i.e. pixels not occluded by another surface). If most pixels are red, the surface is considered to be inside out and its orientation is flipped.

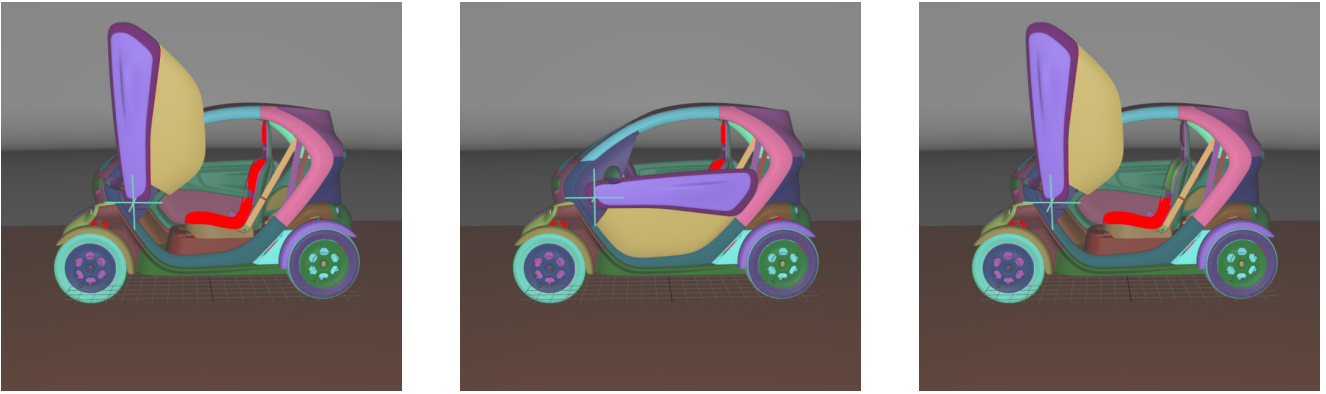

Example of the auto-orientation of visible surfaces function. Initially, some of the seat's surfaces are inside out (left). With the door closed (middle), some of these surfaces are not visible. The auto-orientation function for visible surfaces is used (right): the inside out, non-visible surface retains its original orientation.



Selected Surfaces: automatically orients a selection of surfaces. When a set of surfaces is selected, the function determines the corresponding bounding volume. Fourteen renderings of the selected surfaces are performed for camera positions spread around the bounding volume. If more red pixels than pixels of another color are visible for a given surface, this surface is considered to be inside out and its orientation is flipped.



WARNING

Only visible pixels are taken into account. If a surface is completely occluded by another surface in the selection, it will never be reversed.

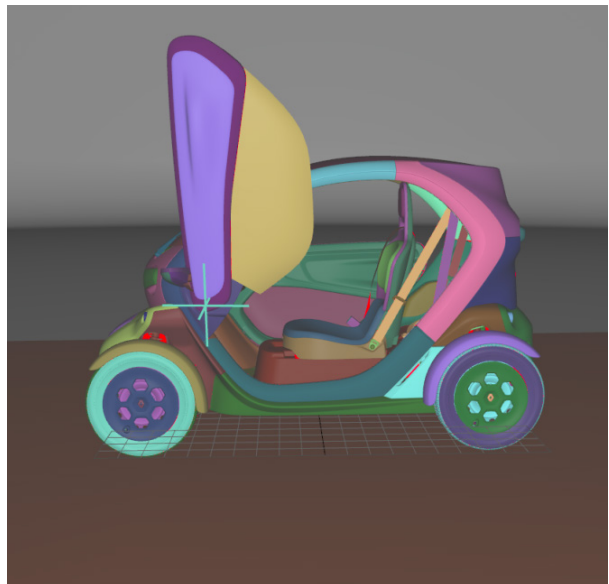
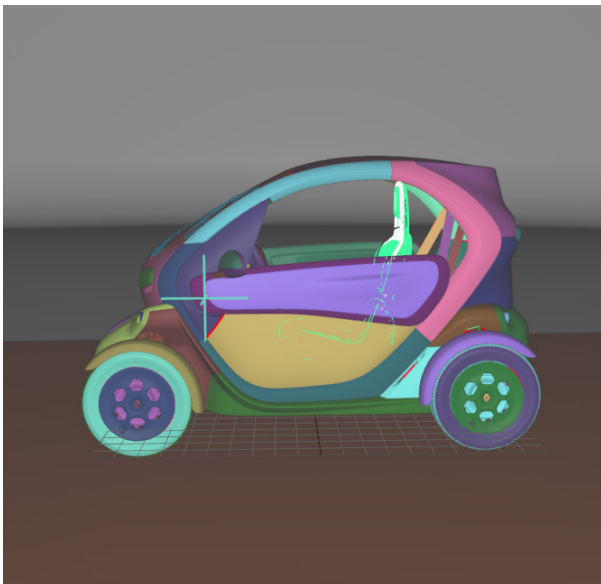
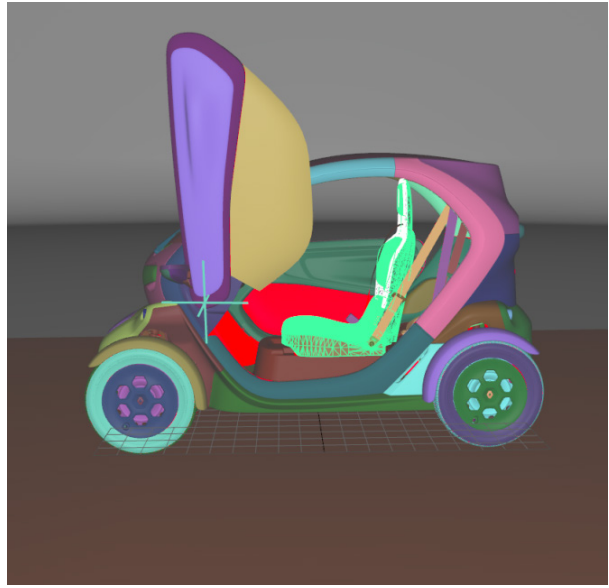
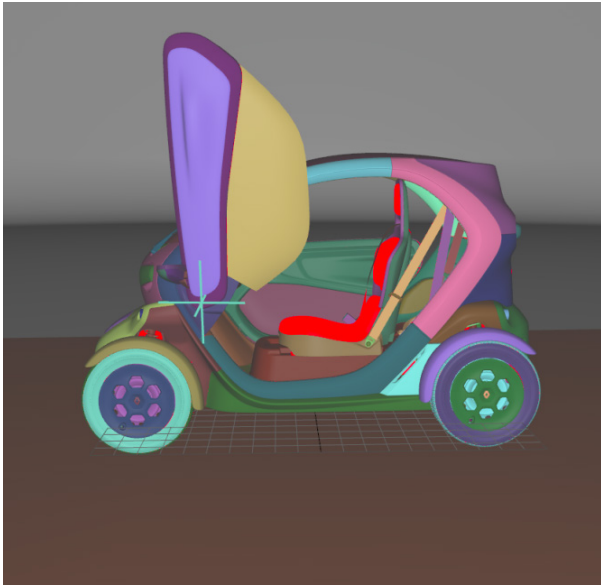

Example of the auto-orientation of selected surfaces function. Initially, some of the seat's surfaces are inside out (top left). All the surfaces of the seat are selected (top right), and the door closed (bottom left). The auto-orientation function for selected surfaces is used in order to orient the surface properly (bottom right).

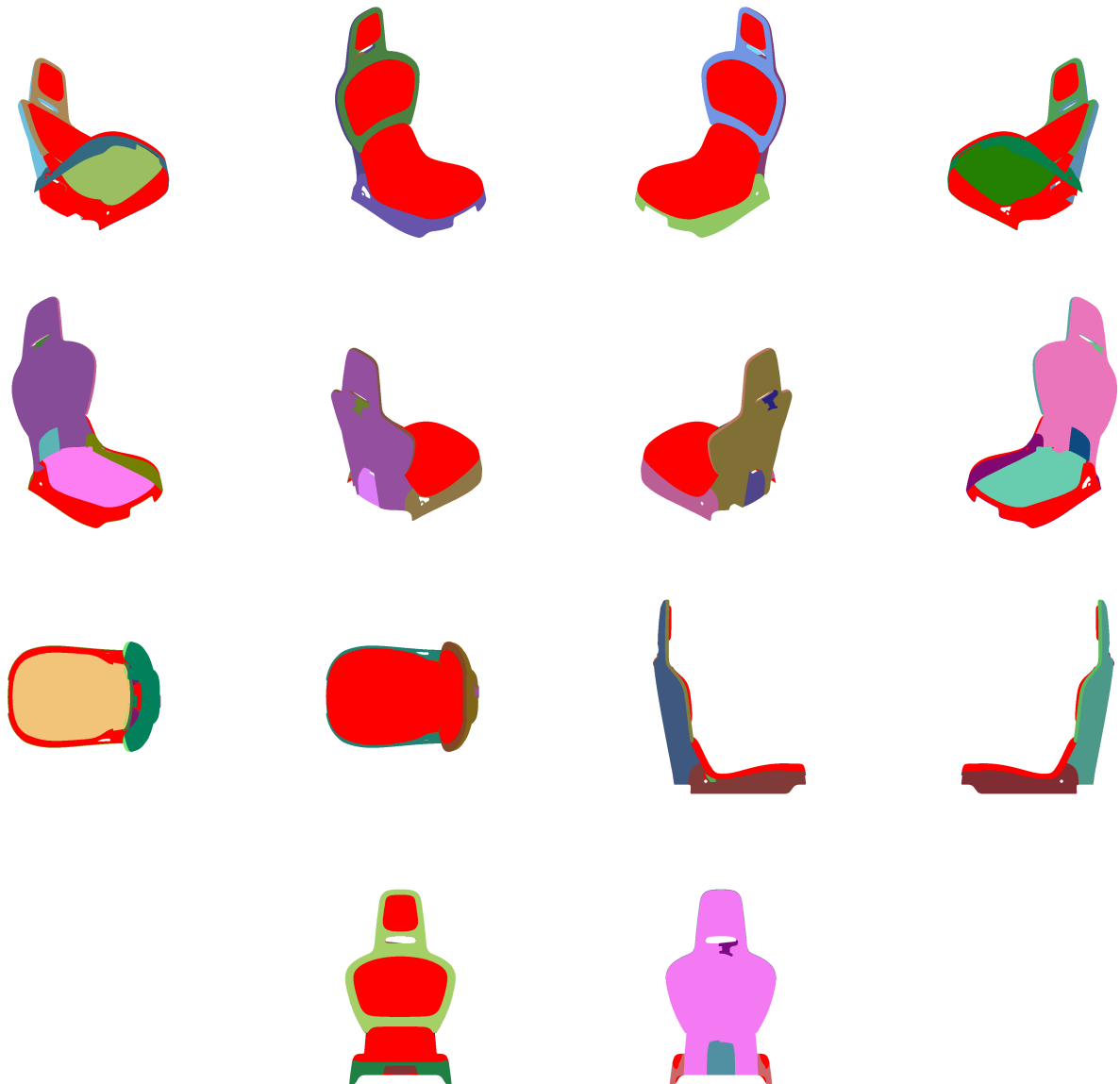

The fourteen intermediate renderings of the selected surfaces performed for the example presented in the previous figure.



Surface towards Interior: automatically orients surfaces towards an interior volume. Six renderings taking all the surfaces in the scene into account are performed from the current camera position in the following directions: forward, backward, up, down, left and right. If more red pixels than pixels of another color are visible for a given surface, this surface is considered to be inside out and its orientation is flipped.



WARNING

As for the auto-orientation function for **Selected Surfaces**, only visible pixels are taken into account. If a surface is completely occluded by another in the selection, it will never be reversed.

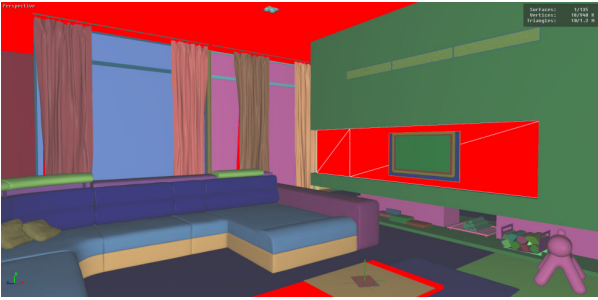

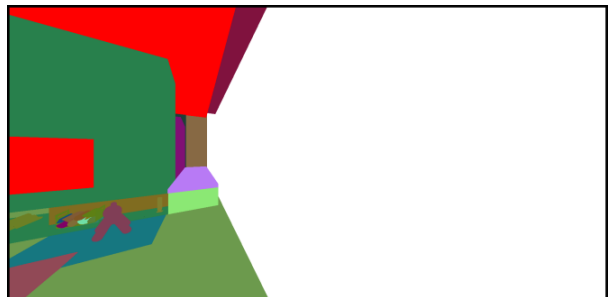
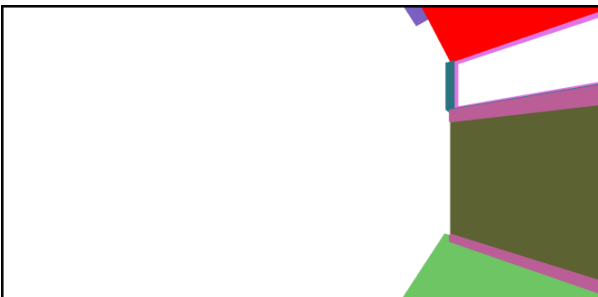
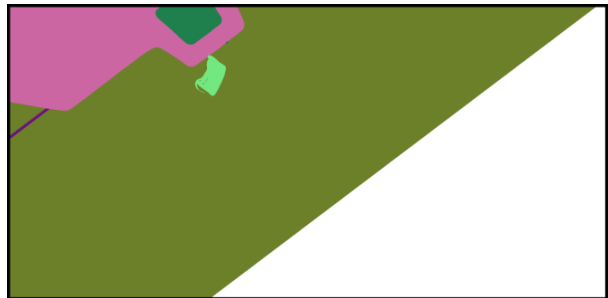
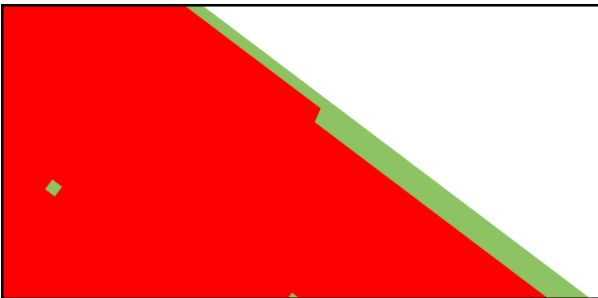
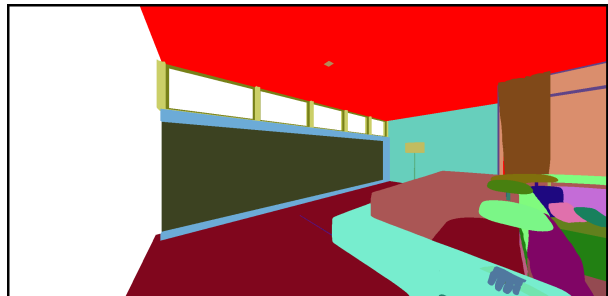
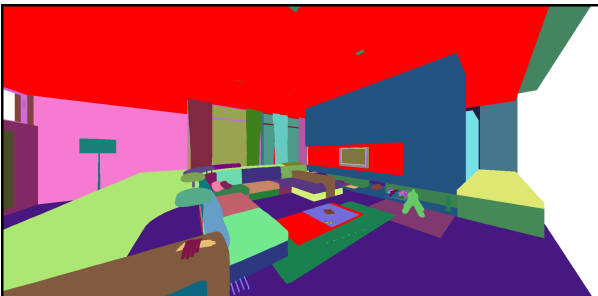

Example of the auto-orientation function for surface interiors on the 3D scene in the left image: the surfaces identified as inside out have been reversed in the right image.



Renderings performed to identify the orientation of each surface with the auto-orientation function for surface interiors. Top: forward and backward. Middle: up and down. Bottom: left and right.

Positioning Surfaces

In *Shaper*, the [gizmos \[76\]](#) allow surfaces to be positioned using the mouse directly in the 3D interface:

-  **Translation:** movement along the X, Y and Z axes.
-  **Rotation:** rotation around the X, Y and Z axes.

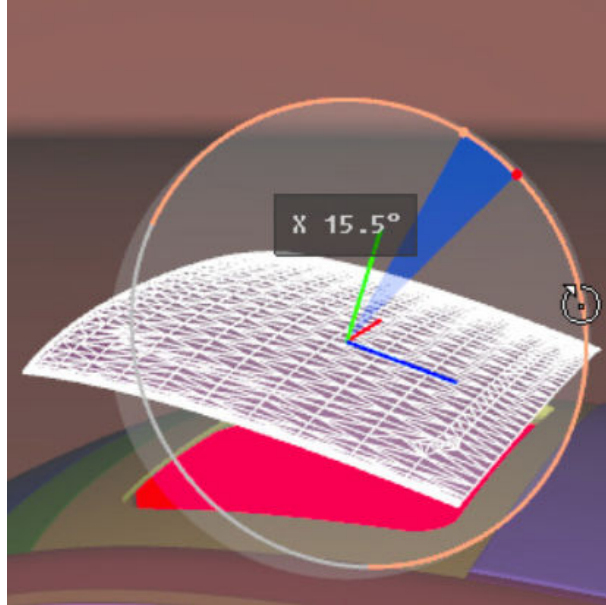
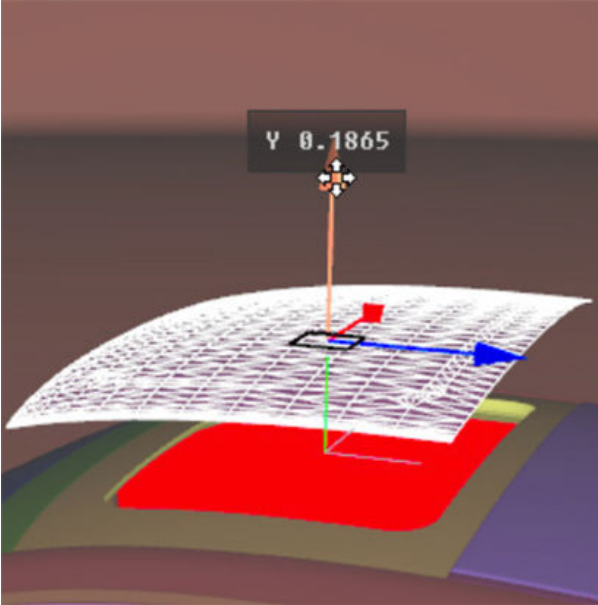

Surface translation along the Y axis; Surface rotation around the X axis.

Surfaces can also be positioned by [providing numerical values \[79\]](#) for the desired orientation and position.

Recalculating Normals

Normals may have to be recomputed when they are either missing or incorrectly imported.



TIP

Display the normals for a selected surface by ticking the **Normals** option in the **Display** box of the **Mapping** sidebar tab.



Reverse Normals: reverses the normals for the selected surface.

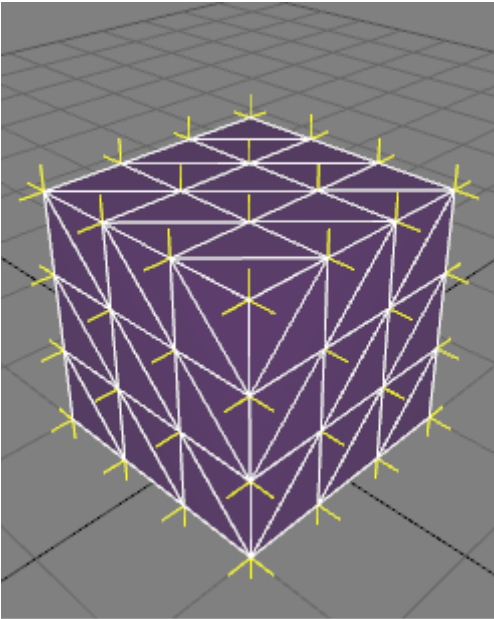

Results of applying the *Recompute normals* function with a threshold angle of 85° on a box.

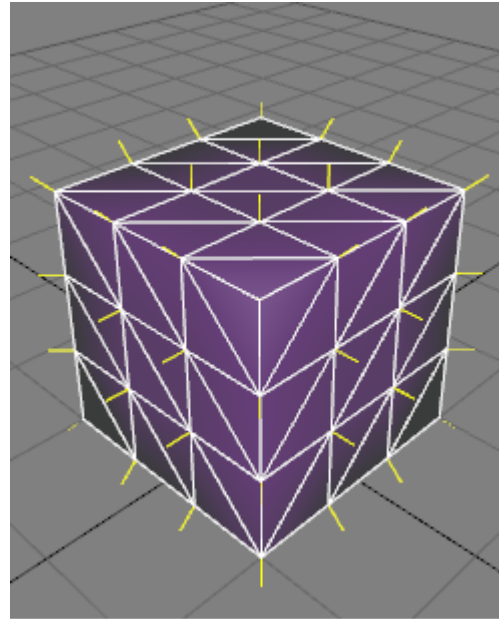

Results of applying the *Recompute normals* function with a threshold angle of 95° on a box.

Surface States

Surfaces can be hidden or frozen.

- A hidden surface is not visible in any viewport. This includes **Matter** viewports.
- A frozen surface cannot be selected or modified.



In **Shaper**, a surface's state is listed:

- As icons in the **Surfaces** box of the **Geometry** sidebar tab,
- By checkbox in the tab **Geometry** from the editor **Surface properties** (keyboard shortcut: **P**).





In **Matter**, a surface's frozen state has no meaning. Its visibility state is listed:

- As a check-box in the **Surface Properties** editor (right-click on the surface in a viewport and choose **Edit properties**).

You can use interaction modes to set the state of several surfaces by clicking on them. These are available from the **Shaper > Mode** menu or from the toolbar:

Icon	Description
	Click to Hide
	Click to Freeze
	Click to Unfreeze

You can set which surfaces are visible from the **Shaper > Visualization** menu:

Icon	Function	Description
	Hide Selected	The selected surfaces are hidden.
	Hide Unselected	The unselected surfaces are hidden.
	Hide Frozen	The frozen surfaces are hidden.
	Show All	All hidden surfaces are made visible.

 **TIP**

 **Show All** is also available from the context menu that appears when you right-click in a **Matter** viewport.

You can set surface states from the viewport context menu that appears when you right-click on a surface in a **Shaper** viewport.

Unfinished Surfaces

Patchwork 3D provides a tracking system for unfinished surfaces, surfaces you believe still need to be handled.

This system uses a specific tag assigned to surfaces marked as unfinished, then employs the **Unfinished Surfaces** tool to easily find and manage the marked surfaces.



For additional information on the surface tag system, please see the chapter [Tag Manager \[186\]](#).

Marking a Surface as Unfinished

By default, surfaces are not marked. To use the tracking system, you must mark surfaces that require work before they can be considered finished.

Marking surfaces is carried out in the Unfinished Surfaces window (**Surface** menu > **Unfinished Surfaces**) or from the **Shaper** interface. Marking is applied to all currently selected surfaces in the **Shaper** viewport.

Select the surfaces you would like to mark. The changes you make will be applied to all surfaces in the current selection. Mark the surfaces to be finished later using the **Shaper** viewport's context menu. Right-click to display the menu, then choose the desired action:

Icon	Action
	Mark all selected surfaces as finished.
	Mark all selected surfaces as unfinished.

These two actions can also be carried out from the **Unfinished Surfaces** window by using the buttons at the bottom of the window.

**TIP**



Marking a surface – or all of the surfaces in a layer – as **finished** can also be carried out in the **Unfinished Surfaces** window by right-clicking on the listing for the surface or for the layer you want to mark. Then, select the option **Mark this branch as finished**.

Finding Unfinished Surfaces

Open the tracking tool for unfinished surfaces from the **Surface** menu > **Unfinished Surfaces**.

A window will open. This window contains the list of **Shaper** layers containing at least one unfinished surface. You can expand the layers to view the surfaces.

Two actions are available for each layer or surface listed:



Icon	Action
	Select the corresponding surfaces in the Shaper viewport.
	Make the corresponding surfaces visible and unlocked in order to allow them to be modified.

If the row in the listing refers to a layer, these actions apply to all of the unfinished surfaces in that layer.

Some modifications will appear automatically in the list. However, it is recommended that you update the list manually using the button at the top right corner of the window.

Surface groupings

Merge and unmerge surfaces



Icon	Function	Description
	Merge surfaces	Allows you to create a single surface from the selected surfaces. This function share UV unfolding and lightmaps in particular.
	Unmerge surfaces	Retrieves initial surfaces from Merge Surfaces function.

**WARNING**

UV unfolding and lightmaps are lost with the functions below:

- Merge surfaces
- Unmerge surfaces

Create and delete a saved selection

Icon	Function	Description
	Create a saved selection	Creates a group of objects in which all of the selected objects will keep their initial states. This is called creating a saved selection.
	Delete a saved selection	Deletes a saved selection.



NOTE

- **Create a saved selection** saves the selection in the Selection editor. Cf. [Selections \(Editor\) \[229\]](#).
- Doing an operation on a saved selection it amounts to doing an operation on each selection of the set.
- Clicking on a surface of a set selects all objects.
- Unlike the merge of surfaces this feature keeps all the properties of the surfaces.
- Compared to a multiple selection, this feature adds the ability to assign a material to a saved selection.

Below are the shortcuts for creating and deleting a set of objects.

Function	Shortcut
Create a saved selection	Ctrl + G
Delete a saved selection	Ctrl + Shift + G



NOTE

A surface can belong to several sets. In this case a contextual menu appears to specify which saved selection to select.

Saved selections can then contain kinematic objects, Bézier paths and mergers of surfaces.

Visual representation

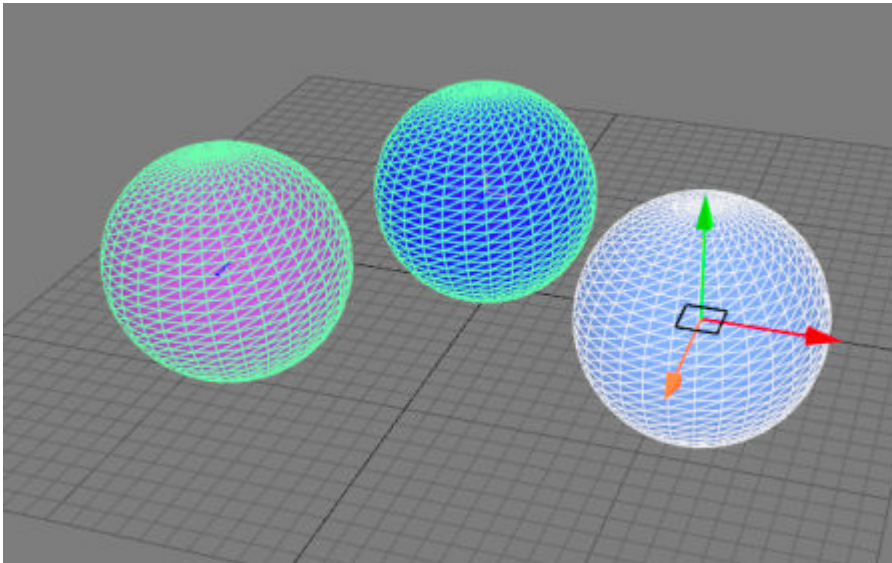

A multiple selection of surfaces

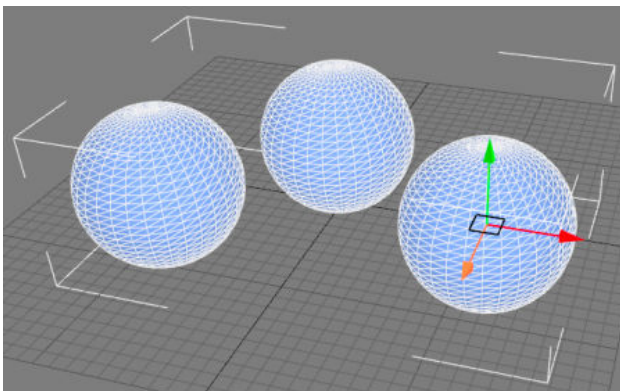

*With the **Merge surfaces** feature, the different geometries form only one surface and therefore have the same color.*

The selection box is white.

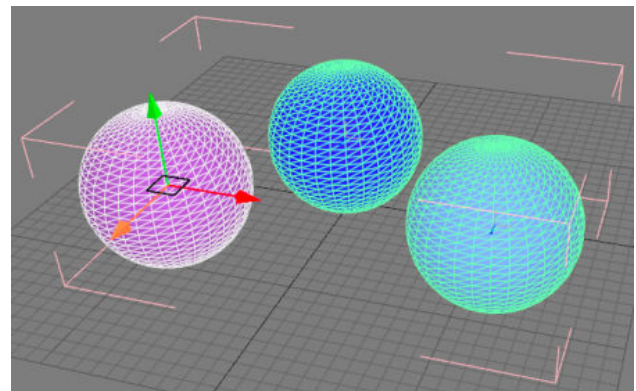

*With the **Create a saved selection** feature all the objects keep their own color.*

The selection box is pink.

Geometric Primitives

Patchwork 3D can be used to create simple geometric primitives: plane, cube, sphere, hemisphere and cylinder. These primitives can be created under the **Model > Create Primitive** menu of **Shaper**.

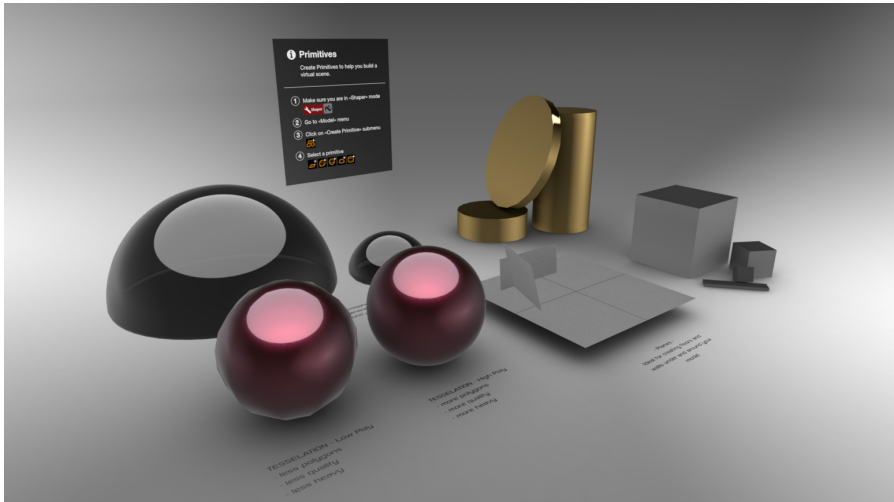

Plane Primitive

Available parameters:

- **Name**,
- **Steps**: number of tessellated divisions per axis,
- **Width**: X axis dimensions,
- **Depth**: Z axis dimensions.

Box Primitive

Available parameters:

- **Name**,
- **Side steps**: number of tessellated divisions per box face,
- **Width**: dimension on the X axis;
- **Height**: dimension on the Y axis;
- **Depth**: dimension on the Z axis;
- **Laid on grid**: positions the base of the box on the XZ plane usually used for defining the ground of the 3D scene.

Sphere Primitive

Available parameters:

- **Name**,
- **Number of meridians**: number of tessellated divisions running from pole to pole. The poles are aligned to the Y axis.
- **Number of parallels**: number of tessellated divisions wrapping around the sphere. These are parallel to the XZ plane.
- **Radius**,
- **Laid on grid**: positions the base of the sphere on the XZ plane usually used for defining the ground of the 3D scene.

Hemisphere Primitive

Available parameters:

- **Name**,
- **Number of meridians**: number of tessellated divisions running from pole to pole. The poles are aligned to the Y axis.
- **Number of parallels**: number of tessellated divisions wrapping around the sphere. These are parallel to the XZ plane.
- **Main radius**: radius of the corresponding sphere. Consequently, this is also the height of the hemisphere.
- **Edge radius**: radius of the bottom edge of the hemisphere. This dimension must be smaller than the main radius. This creates a rounded bottom edge, which improves visual quality when the hemisphere is used as a skydome.

A hemisphere is always automatically positioned on the XZ plane usually used for defining the ground of the 3D scene.

Cylinder Primitive

Available parameters:

- **Name**,
- **Circle steps**: number of tessellated divisions around the edge of the circular cap of the cylinder,
- **Height steps**: number of tessellated divisions along the vertical edge of the cylinder,
- **Radius**,
- **Height** ,
- **Axis**: sets the axis along which the height of the cylinder is aligned,
- **Laid on grid**: positions the base of the cylinder on the XZ plane usually used for defining the ground of the 3D scene.

Edit Primitive

It is possible to edit the dimension of primitive by interactively modifying its parameters, either in **Shaper** or in **Matter**.

There are two choices for editing a primitive:

- When creating a primitive in **Shaper** from the menu by choosing **Model > Create Primitive**. With the **Primitive** editor that opens you can set the parameters for the selected primitive type. See the parameters above.
- After creating a primitive, in **Shaper** and **Matter** you can also change the dimensions of the selected primitive by right-clicking on it and choosing **Edit Primitive**.



WARNING

Changing the dimensions of a primitive is only available with primitives that have been created in Patchwork 3D versions 2020.1 and higher. Primitives created in earlier versions are not editable.

Kinematic Primitives

Kinematic primitives are used to parent surfaces and create kinematic, animatable groups. They have no creation parameters but can be edited from the Kinematics sidebar tab. These objects are not surfaces; they are invisible in finished products and cannot receive materials.

Three kinematic primitives are available:

- **Axis**,
- **Null object**,
- **Vector**.

For more information, see the section [Animation Utility Objects \[448\]](#).

PIVOTS

Each surface has a local tab known as a **Pivot**. A pivot is a surface's attachment point. It is generally positioned at the origin of the surface's local axes and it indicates the orientation of the axes. Local axes are used when you wish to group surfaces and move the group together, or when you are preparing an animation.

If the  **Pivot** tab is active in Shaper, the pivot of a surface is visible when the surface is selected.

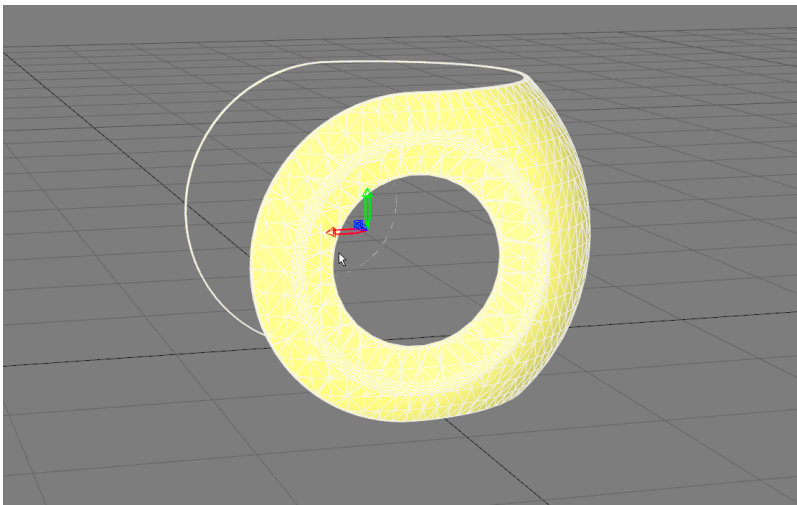

A pivot of a surface.

Operations on Pivots

The operations in the  **Pivot** tab in the Shaper sidebar make it possible to move the pivot without modifying the position of the surface in the environment (the relative position of the surface to its pivot is thus modified in consequence).

The operations for translating the pivot are the following:

Translation option	Description
Center on Surface	Centers the pivot on the surface.
Center on Selection	Centers the pivot on a group of surfaces.
Center to Selection Leader	Centers the pivot on the surface designated as the leader of the selection.
Center in World	Places the pivot point at the origin, at the intersection of the world axes.
Reset	Returns the pivot to its original position.

The orientation of the pivot can also be modified:

Orientation option	Description
<i>Align to World</i>	Orients the pivot along the environment origin.
<i>Reset</i>	Returns the pivot to its original orientation.

The transformation function ***Reset Position Relative to Pivot*** moves the surface to the center it at the location of the pivot.

The other transformations that can be performed on the pivot (**translation, rotation, constraints on axes [76]**, etc.) are the same as those that may be performed on the surfaces.

UV MAPPING

Mapping is an operation that consists of drawing a regular grid directly on the surface. The materials that will be applied to the surfaces in **Matter** are cut along and positioned in accordance with the grid. If the grid is deformed, the material applied to the surface will present the same deformation.

Most materials are not deformable or support only slight deformations. Consequently, the mapping grids must be regular and only slightly deformed.



Before mapping.

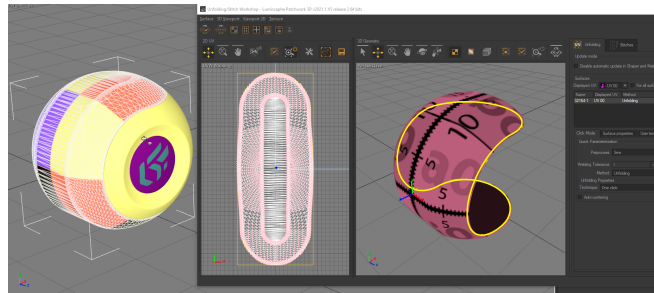

Mapping assignment.



After mapping.

The **Dressing** tab  in the **Shaper** sidebar contains a panel that shows the tools used for mapping surfaces.

By default, surfaces created in **Shaper** contain no mapping information. Surfaces without mapping cannot receive material and appear grayed out in **Matter**.

Assigning Mapping

To assign mapping to the surfaces, **Shaper** has two methods: the extraction of mapping predefined in the CAD tool before importing into Patchwork 3D, and the creation of mapping by projecting a geometric grid onto the surface.

Several types of projection may be used: planar projection, spherical projection, cylindrical projection, etc. The appropriate choice of the projection method makes it possible to obtain a regular or almost regular grid on the majority of surfaces and thus to minimize the deformation of the materials that will be applied in **Matter**.

Adjusting the projection parameters is facilitated by using gizmos. A gizmo is the symbolic representation of a projection in a 3D view. They are in the form of simplified 3D objects attached to surfaces.

Each is positioned in space relative to the pivot of the surface to which it is attached. The relative position of a gizmo with respect to its surface is therefore not modified when you move the surface.

A certain number of parameters influence the projection: by modifying the position, the orientation, the length, the height and the width of the gizmo, you can squash or stretch the mapping grid along the main projection axes.

To assign mapping to a surface, select the surface and choose a mapping function in **Type** drop-down menu of the **Mapping** box.

The gizmo represents the two main axes U and V of the projected grid. The U axis corresponds by default to the horizontal line of the materials, and the V axis to the vertical line. Certain gizmos project several grids onto the surface and locally select the most suitable one.

Mapping Operators

Shaper offers eight different functions for defining the mapping of a surface:

- **Extraction** for the unfolding workshop,
- **Planar** projection,
- **Box** projection,
- **Open box** projection,
- **Spherical** projection,
- **Cylindrical** projection,
- **Closed Cylindrical** projection,
- **Torus** operator.

The choice of mapping operator is made through a selector in the **Mapping** panel of the **Shaper** interface. By default, no mapping operator is assigned to a surface.

Extraction

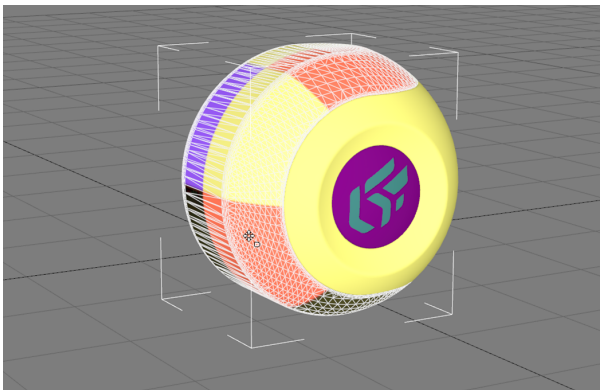

Certain 3D modeling tools can attach UV mapping information to the surfaces. When importing models, Patchwork 3D attempts to conserve this information, which remains attached to the surfaces. This is the case, for example, for importing Autodesk 3DS Max models.

Extract mapping operator allows you to apply the unfolding made in the unfolding workshop depending on the selected UV set. Cf. [Unfolding & Stitch Workshop \[114\]](#)

Planar Projection

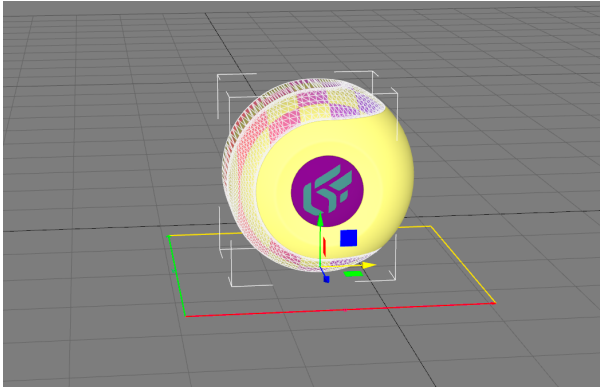

The **planar projection** projects a grid perpendicular to a plane. The effect obtained is similar to the projection of a transparency slide onto the surface. This type of projection is suitable for flat, sparingly deformed surfaces. The gizmo represents the plane containing the grid.

Box Projection

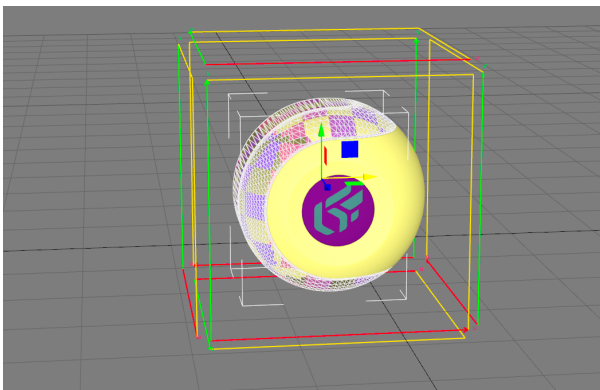

The box projection is the simplest projection to use and the one that is the most multi-purpose. The gizmo takes the form of a box that surrounds the surface. Each face of the box corresponds to a planar projection.

You can use this projection operator in most situations, since the resulting mapping grid is sparingly deformed, irrespective of the geometry of the surface.

On the other hand, the material can be cut into several pieces to cover the surface.

This mapping operator is ideal when you use uniform materials bearing no pattern.

Open Box Projection

This projection operator is similar to the **Box Projection**. The gizmo takes the form of a four-sided box with no base and no lid.

Spherical Projection

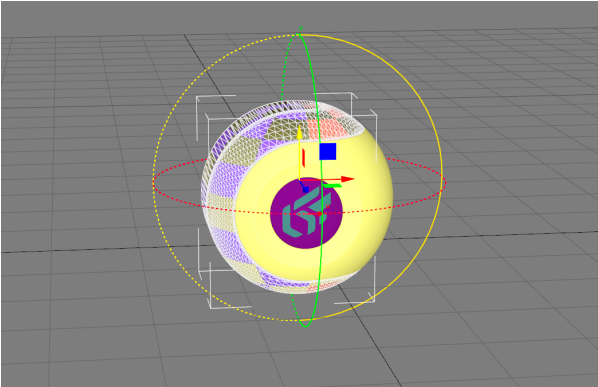

The **spherical projection** projects the grid as polar coordinates. The gizmo takes the form of a sphere. The longitude and latitude correspond, respectively, to the U and V axes of the grid.

Cylindrical Projection

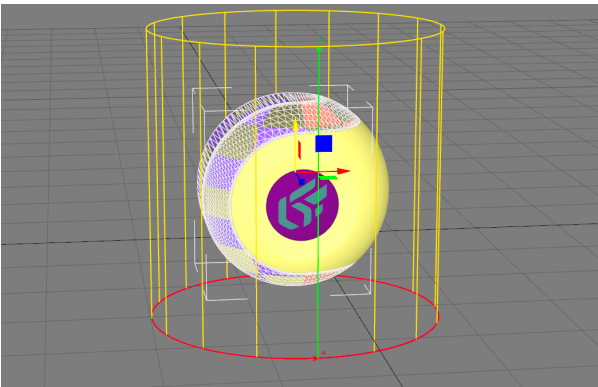

The **cylindrical projection** projects the grid as cylindrical coordinates. The gizmo takes the form of a cylinder. The longitude and the height in the cylinder correspond, respectively, to the U and V axes of the grid.

Cylindrical with Cap Projection

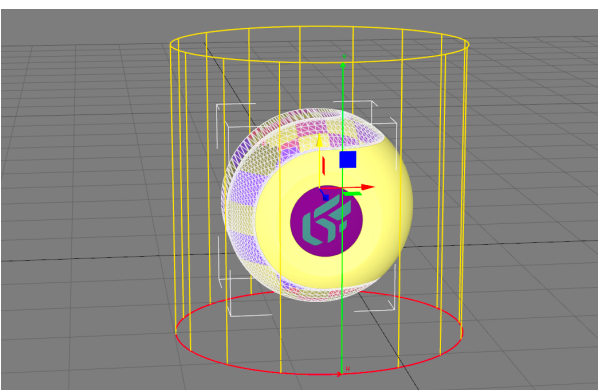

The cylindrical with cap projection is similar to the **cylindrical projection**. The gizmo takes the form of a cylinder that is capped at both ends.

The two faces at the ends of the cylinder behave like planar projections. The orientation of the surface is used to determine which grid should be used.

Transforming Mapping Gizmos

In **Mapping** mode, activated by clicking on the Mapping sidebar tab in Shaper, you can modify the position of a gizmo with the translation and orientation tools. The dimensions of a gizmo can be edited from the **Mapping** sidebar tab.

UV mapping scaling

Scaling surfaces using **dedicated gizmo [78]** affects UV mapping.

- You have the possibility to scale the UV mapping according to the resizing of the surfaces with the option **Apply the geometry scaling to UV** available in the tab **Mapping** tab of **Shaper** at box level **Area**. This will keep the scale of the UV mapping. This option is activated by default.
- On the contrary, you can also choose not to scale the UV mapping according to the modifications of the surfaces by unchecking the option.

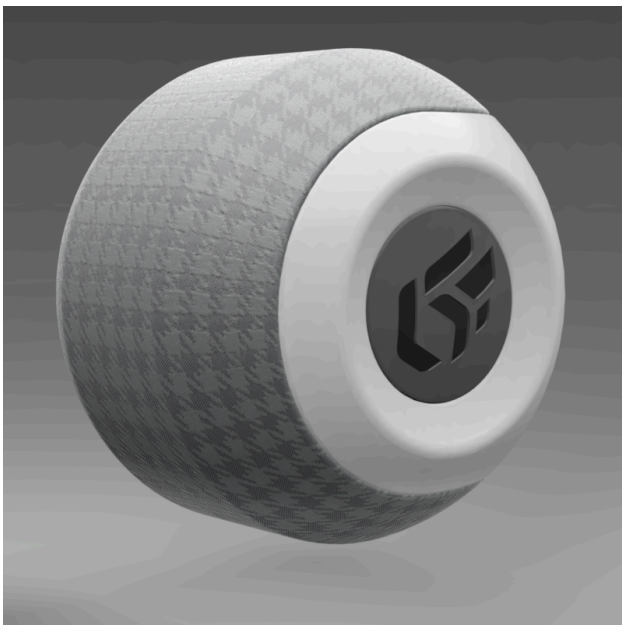

UV mapping WITH geometry scaling

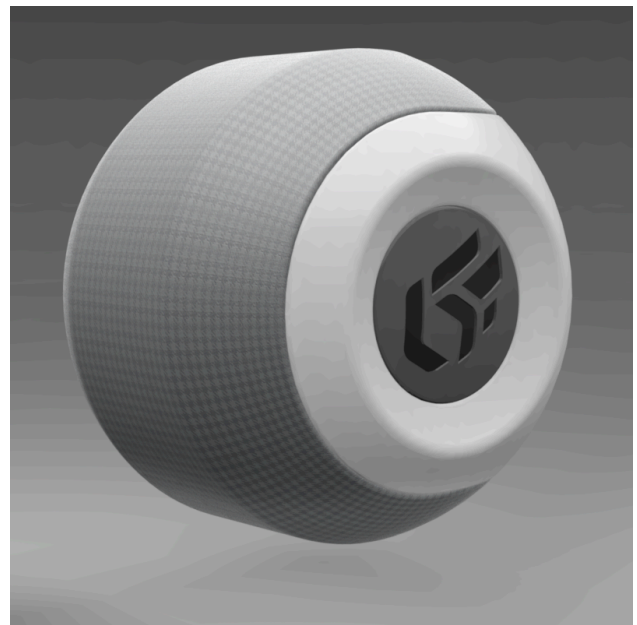

UV mapping WITHOUT geometry scaling

Repetition on the U and V Axis

The repetition factors enable the grid to be expanded in the U or V direction. The orientation of the U and V axes can be inverted by specifying negative values or by directly using the commands **Flip U** and **Flip V** in the **Tiling** zone of the **Mapping** sidebar tab.

Automatic Alignment

Several tools in the **Alignment** box in the sidebar facilitate the alignment of the gizmo on the surface:

Tool	Description
<i>Fit to Size</i>	Adjusts the size and position of the gizmo so that it bounds the surface.
<i>Center</i>	Positions the center of the gizmo on the center of the box bounding the surface.
<i>Align XY</i>	Aligns the gizmo on the XY plane.
<i>Align YZ</i>	Aligns the gizmo on the YZ plane.
<i>Align ZX</i>	Aligns the gizmo on the XZ plane.
<i>Fit Size to Selection</i>	Aligns the gizmo on the plane of the 3D active view.
<i>Center on Selection</i>	Positions the center of the gizmo at the center of the box bounding the selection.

Viewing the Mapping Information

You can view the surface mapping directly in the solid 3D views by enabling one of the options in the **Reference Texture** option box. A setting texture appears on the surface and gives a preview of the position of the mapping grid on the surface. Two reference textures are available: a checkerboard and a coordinate texture showing the corners and the center of the grid.

KINEMATICS









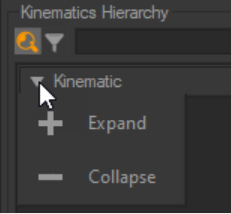

The  **Kinematics** tab of the **Shaper** sidebar has two functions.



- First, it allows a functional hierarchy of moving parts to be developed. Each movement is represented by a null object: a **null**, an **axis of rotation**, or a **translation vector**. Axes of rotation and translation vectors create a single type of movement: an axis of rotation is only animated in a rotation around its axis, and a translation vector is only animated along the direction it defines.
- Secondly, the **Kinematics** tab also allows parts to be associated with groups of objects. During an animation, these objects move together following the movement of the part to which they are attached.

In the kinematics hierarchy, the motions of elements can be linked to parent or child elements.

Use the **Kinematics Hierarchy** buttons listed below to perform the desired actions.

Clicking on one of the creation options adds a new part to the kinematic hierarchical tree and selects this new part.

Icon	Description
	Detach the kinematics hierarchy from the sidebar to use it, for example, on a second screen. This allows you to modify both the kinematics hierarchy and the geometries hierarchy.
	Expand/collapse the kinematics hierarchy.
	Add an axis to the hierarchy.
	Add a null to the hierarchy.
	Add a vector to the hierarchy.
	Insert an axis child to the kinematics hierarchy.
	Insert a null child to the kinematics hierarchy
	Insert a vector child to the kinematics hierarchy
	Assign the selected surface(s) to an object. How to do that? [295]
	Pick the parent of the selected objects. How to do that? [295]
	Unparent selected objects. How to do that? [295]
	Import hierarchies that you have previously saved.

Icon	Description
	Export selected hierarchies.
	Rename the selected hierarchy.
	Delete selected hierarchies.

When a part is selected, the **Part** panel in the sidebar will show the options for editing the part's properties. The rotation axis or the translation vector is also presented in the 3D viewport. They allow the animation to be manipulated manually. They are visible only when the **Surfaces** tab or the **Kinematics** tab is selected. The representations for null objects, rotation axes, and translation vectors each have their own **Shaper** colors. When they are selected, they behave like other **Shaper** objects such as surfaces: they are highlighted in white when selected, or in green when they are part of a selection but not the selection leader.

Modifying the Hierarchy

Drag and drop parts within the sidebar to change their position in the hierarchy. When you move a part, all of its child objects are moved with it.

Additional options are available in the context menu. Bring this menu up by right-clicking on the part you would like to modify.

Hierarchy parts are all **Shaper** objects. This means that you can modify their properties in the **Properties** editor. For easy access, the Properties are also available from the context menu that appears when you right-click on a part.

You can rename the object directly by choosing the **Rename** option in the same context menu.

Saving the Hierarchy

The kinematic hierarchy can be saved by exporting it.

Use the  button to export the hierarchy.

This action saves the hierarchy of nulls, vectors, and axes as a KKI file. The parenting of surfaces to the hierarchy parts is not saved.

KKI files can be reimported into this database, or imported into any other P3D database using the  button.

When a kinematic hierarchic file is imported, its nodes are added to the current kinematic hierarchy. If you wish to replace the current kinematic hierarchy with a saved hierarchy, delete the current hierarchy parts before importing.

Kinematic Properties of Hierarchy Parts

Properties of Rotating Parts

The **Endpoints** zones set the world coordinates of the endpoints of the axis around which the part pivots.

The **Pick**  buttons allow you to set the position of an endpoint of the axis with a click in the 3D view. Clicking on this button opens a menu that defines the picking behavior. You can choose whether the endpoint should be placed:

- At the location of your click,
- At the center of the clicked surface,
- At the pivot of the clicked surface.

The  button switches the position of the endpoints. This can be useful to reverse the direction of rotation around the axis.

The **Min** and **Max** angle fields set the limits between which the part can be animated.

The **Show in Animation Slider Editor** option is checked by default. This allows the animation of this part to be played manually using the **Animation Slider Editor** in **Matter**.

Properties of Translatable Parts

The **Vector** zone allows the endpoints of the translation vector to be provided in world coordinates. The

Pick  buttons allow you to set the position of an endpoint of the vector with a click in the 3D view. Clicking on this button opens a menu that defines the picking behavior. You can choose whether the endpoint should be placed:

- At the location of your click,
- At the center of the clicked surface,
- At the pivot of the clicked surface.

The  button switches the position of the endpoints.

The **min** and **max** distance fields limit the distance over which the part can be animated.

The **Show in Animation Slider Editor** option is checked by default. This allows the animation of this part to be played manually using the **Animation Slider Editor** in **Matter**.

Properties of Freely Transformable Parts

In the **Settings** zone, you can provide the world coordinates of a null's position. The **Pick**  button allows you to set the position of the null with a click in the 3D view. Clicking on this button opens a menu that defines the picking behavior. You can choose whether the null should be placed:

- At the location of your click,
- At the center of the clicked surface,
- At the pivot of the clicked surface.

List of Objects Belonging to Parts

The objects belonging to the part, whether other parts or surfaces, appear listed as children under the part node. These objects will be moved when the part is animated.

If the **Sync with selection** box is checked, selecting an object in the list also selects it in the 3D viewport and vice-versa. This helps you locate objects easily in the viewport.



Assigning Objects to a Parent Part



NOTE

Objects to be assigned to parent parts must not be frozen.

Surfaces cannot be used as parent parts.

Icon	Assignment action
	This is the assignment shortcut. In the viewport, select the objects you want to assign as children. Drag and drop this icon onto the kinematic hierarchy node to be used as their parent.
	The Pick parent of selected objects tool assigns a parent to the selected objects. First, select the desired child objects. Click the button, then click on the representation of the parent in the viewport.
	The Unparent selected objects tool removes the parent-child links from the selected objects. Select the objects to be unparented in the Kinematic Hierarchy or in the viewport, then click the button.

You can also right-click on an object or a group of objects listed in the **Kinematic Hierarchy** in the sidebar. This will bring up a context menu offering several operations that can be performed on this object.

Assignment Modes

The kinematic function proposes two modes for associating objects with a parent. One keeps the objects' positions relative to the origin, or center, of the 3D scene; the other orients their positions relative to the parent's position.

Keeps Child's World Position

This mode conserves the position of the surface as a function of the scene origin.

No change in position will occur, but the child object will be listed under the parent node in the **Kinematic Hierarchy**.

1. Select the child object.
2. Select the **keeps child's world position** option in the **Parenting an object** zone.
3. Click on the **Pick parent** button located in the **Operations on selection** zone.

Aligns to Parent-Relative Position

This mode conserves the position of the child objects relative to that of the parent part.

1. Choose the **aligns to parent-relative position** option in the **Parenting an object** zone.
2. Click on the **Pick the Parent** button.



NOTE



The child objects derived from the relationship appear highlighted and position themselves relative to the parent, and also relative to the reference in the 3D space.

If no change appears on the screen once the parent relationship has been established, zoom out to obtain a wider field of view and observe the transformations.

Repositioning Parts and Their Associated Objects



The mode , enabled by default, allows objects such as surfaces to be transformed when their parents are transformed. Deselect this mode in order to reposition objects that are already part of a parent-child relationship. This will prevent objects such as surfaces associated with a part from being moved when you reposition the representation of the null, axis, or vector.

You can reposition all objects by using the translation gizmos  and rotation  located in the **Shaper** toolbar.

Animation Constraints

Animation constraints define how certain **Shaper** objects move in relation to others. This relationship is defined by the object to be constrained, its target, and the type of constraint. Constraints can affect the position of an object, the orientation of an object, or both at the same time.

Animation constraints are defined in the **Kinematics** tab of the **Shaper** sidebar:

1. Select the objects to be constrained.
2. Click on the  button to add a constraint to the selected objects.
3. A context menu appears. Select the type of constraint that will be created.
4. An eyedropper appears. Use this tool to select the target in the viewport. For example, if the selected null should follow a Bézier path, use the eyedropper to select the Bézier path.

Managing the List of Constraints

The list of constraints in the **Kinematics** tab shows the constraints applied to the selected object or objects in the **Shaper** viewports. To view all of the constraints for a model, select all **Shaper** objects.

Constraints are taken into account in the order that they are listed. The position and the orientation of an object are evaluated separately and assigned to the first constraint in the list that applies to them. Constraints further down the list will have no effect on an object's orientation or an object's position if it has already been constrained.

Constraints cannot create circular reasoning. When a new constraint would create circular reasoning, an error will appear indicating the object of the constraint causing the conflict. If you really want to create the new constraint, you must first delete the conflicting constraint from the list.

To modify an existing constraint, select it in the list. Use the  button to activate an eyedropper, then select a new target in the viewport. The new target will replace the old target in the selected constraint.

Use the  button to delete the selected constraint from the list.

Position Constraints

Position constraints assign the target's position to the object. If the target is a moving part, the object will also be affected by the changes to the target's position.

To avoid having two objects that occupy the same position in the 3D world, assign an offset to the constrained object. An offset is defined below the list of constraints using the XYZ coordinates to express the difference between the target's position and the object's position. When the target is repositioned, the object will also be repositioned and the offset distance will be maintained.

Orientation Constraints

Orientation constraints assign the target's orientation to the object. If the target is a moving part, the object will also be affected by changes to the target's orientation.

The object's orientation and the target's orientation are defined by their pivots, which set their local coordinates. The rotational transformation that is applied to the target's pivot will be applied to the object's pivot.

Two methods exist for setting different orientations for the object and the target with an orientation constraint:

- Modify the orientation of the local pivot for either the object, the target, or both.
- Set an orientation offset below the list of constraints. The offset should be provided in X, Y, and Z angles. It will be applied to the object's pivot.

Look At Constraints

Look At constraints use the position of the target to set the orientation of the object. If the target is a moving part, when the target is repositioned in the 3D world, the object will rotate in order to face it.

The object's face is defined by its pivot and by the settings below the list of constraints:

Setting	Default	Description
<i>Aim axis</i>	local X axis	Defines the local axis of the object's pivot that is oriented towards the target.
<i>Up vector</i>	local Y axis	Defines the local axis of the object's pivot that points upwards.

To make fine adjustments the alignment of the object's face, adjust the object's pivot.

Follow Path Constraints

Follow Path constraints allow an object to use a target Bézier curve as a path. When the Bézier curve's path constraint is animated as a channel animation, this affects the object's position. If the option **Align to path** is checked, it also affects the object's orientation.

The object follows the Bézier path starting from the path's start point and progressing in the same sense as the path. You can change the start point by:

- Right-clicking on the Bézier path where the start point should be placed and selecting **Place start here**.
- Modifying the **Position along path** setting below the list of constraints. Provide location along the Bézier curve by entering a percentage of the curve.

If the option **Align to path** is checked, the object will rotate so that its face is always oriented in the direction of travel along the Bézier path. Below the list of constraints, you can define:

Setting	Default	Description
<i>Aim axis</i>	local X axis	Defines the local axis of the object's pivot that is oriented towards the direction of travel along the Bézier path.
<i>Up vector</i>	local Y axis	Defines the local axis of the object's pivot that points upwards.

LIGHTING

Illumination in Patchwork 3D is provided by light sources. These light sources can be any of various types: sky, spot, omni, sun or area. Light sources of all types are grouped into lighting layers, which can be combined to create complex illumination set-ups. The set of visible layers and their coverage provides a total illumination set-up which is used to calculate lightmaps.

Lighting is managed in the  **Lighting** tab of the **Shaper** sidebar. At each level – light sources, lighting layers, and full illumination set-up – settings are available to adjust the lighting properties.



TIP

To be able to render lighting, the lighting engine must be enabled in the [application settings \[53\]](#).

You may also find the following information helpful:

- [Lighting Layers \[407\]](#),
- [Distributed illumination calculation \[314\]](#).

This chapter covers:

Type of illumination rendering

The render configuration settings apply to the entire illumination set-up. They take into account all of the lights and layers, and their properties, including visibility and activation.

In the **Rendering** zone, you can set the **type of lighting**:

Type of lighting	Description
Environment	The Environment mode is the type of lighting established by default. In this mode, none of the existing light sources are taken into account. Sufficient light is assumed to be generated by the model's environment. The model is not affected by the illumination configuration.
Lightmap	The Lightmap mode allows you to apply calculated lighting on the model.
Preview	The Preview mode provides an interactive rendering of the shadow regions. This allows you to evaluate the placement and orientation of the light sources relative to the objects and camera viewpoint. Only the active lighting layer is visible in Preview mode.

The type of rendering that is chosen will also be applied in **Matter**, except in the case of **Preview** mode, which will be replaced with **Environment** in **Matter**.

Type-specific settings are available below the **Type of lighting** list for the chosen lighting type.

Preview Mode

When the **Preview** mode is selected, the following options can be enabled or disabled:

Option	Description
Interactive degradation	When enabled, this option pauses the calculation when the object is being manipulated in the Ctrl +right mouse button and middle mouse button operating modes.
Restrict to shadow integrity	When enabled, this option restricts the calculation of Preview illumination depending upon the selected shadow integrity mode.
Preview color	When enabled, the preview takes the light sources' colors into account. When disabled, the preview is shown in grayscale.
Preview bounded attenuation	When enabled, the attenuation gizmo indicates the full effect and falloff distances. The surface parts illuminated without light attenuation are displayed in red. The surface parts illuminated with light attenuation are displayed in pink.

The default shadowmap size provided in the [application settings \[53\]](#) is used for the preview mode.

Calculating Lightmaps

When at least one of the visible lighting layers is a lightmap, the lightmap must be calculated before the illumination will be visible.



TIP

The lighting resolution and the shadow size are each set by default at 2048 and 1024 pixels, respectively. In [the settings \[58\]](#), you can increase the lighting or shadow definition for greater fineness when working on an object. Keep in mind, however, that the calculation will be slower as a result of more intensive image information processing.

Select the **Lightmap** mode. Choose the layers and the surfaces for which lightmaps should be calculated, then use the rendering buttons to render the lightmaps.

Filtering Layers

The **Layers** filter specifies which layer or layers to take into account when calculating lightmaps.

Filter	Description
All	Lightmaps will be calculated for all of the layers.
Visible	Only the lightmaps for the layers that are visible in the current configuration will be calculated.
Active	The lightmap for the active layer will be calculated, even if this lighting is not visible. The active layer is the layer that is currently selected. If multiple layers are selected, the active layer is the layer bordered by a dotted line in the Layers list.

Filtering Surfaces

The **Surfaces** filter allows you to restrict the surfaces for which lightmaps will be calculated.

Filter	Description
All	Lightmaps will be rendered for all surfaces.
Selected	Select surfaces directly in the 3D product view from the Lighting tab of Shaper . Direct surface selection saves time as it is not necessary to switch to the Surface tab to select a surface requiring a lightmap computation. The selected surfaces for which lightmaps will be calculated will be highlighted in green.
Unlit	Lightmaps will be rendered only for surfaces for which no lightmap has been calculated yet.

Setting the Render Quality

A slider allows you to determine the speed at which lightmaps are calculated by setting the balance between speed and precision. The default slider position (50) sets an advantageous rendering speed that preserves global lightmap quality in most contexts.

You can modify this setting by moving the slider towards one of the extremes:

Rendering quality	Description
Faster	Rendering speed is increased. The precision of the lightmaps created by this calculation is decreased.
More accurate	Priority is given to the precision of the lightmaps being calculated. This calculation takes longer to carry out.

Launching a Lightmap Render

Two render calculation modes exist:

Mode	Description
Start Local Rendering	Use this option to calculate lightmaps using your computer's resources.
Start Distributed Rendering	Use this option to calculate lightmaps using the resources of a network of computers running Patchwork Lightmap Render. More information on distributed rendering can be found in the chapter Distributed Lightmap Rendering [314] .

The option **Show while rendering** allows you to visualize the result of the calculation before the calculation has been completed. When this option is enabled, as soon as the lightmap for a surface is calculated, it is shown in the viewport. Surfaces for which the lightmap has not yet been calculated are displayed in red.

If you are calculating lightmaps for multiple layers, the display will switch to the layer for which lighting is being calculated if **Show while rendering** is checked.

**TIP**

When no *lightmap* has been calculated for a given surface, it is displayed in red in both *Shaper* and *Matter*.

Options for Existing Lightmaps

**NOTE**

Surface and layer filters for lightmap calculation are also applied to the following functions.

Once a lightmap has been calculated, you can:

Operation	Description
Update	Update the lightmap to view the lightmap in a different lightmap format [409] .
Export	Export the lightmap as a series of image files.
Remove	Remove the lightmap. This deletes the lightmap completely. A deleted lightmap can be recalculated from scratch but cannot be restored.



Light Sources

Lighting is organized into [lighting layers \[407\]](#). Each layer contains at least one light source.

Select a layer by clicking on it to add, delete, or modify the light sources in that layer. In the **Light Sources** zone, the light sources in the current layer are listed.

As soon as you create a light, you have a near-immediate view of the result in Patchwork 3D's material render mode. This interactive mode is useful for fine-tuning your lighting, placing your light sources and for adjusting their intensity.

Icon	Description
	New light group.
	New light source.
	Duplicate the light source.
	Delete the light source.
	Align the main light source with the camera.
	Align the camera with the main light source.

Icon	Description
	Position the lights at a point to be selected.
	Orient the lights towards a point to be selected.
	Show Light Gizmos shows or hides the representation of the lights in the viewports.

To create a new light source, click on the  **New light** icon.

The first light created in a layer is always of the type **Sky**. The following are types: **Spot**, **Sun**, **Omni**, or **Area**.

Once the light source has been created, its type can be modified at any time.

Right-click on a selection of sources in the list. This opens a context menu that lets you create a copy of the selected light sources on another lighting layer.

To delete a light source, select the light source to delete in the lights list, then click on the  **Delete Selected Lights** icon.





TIP

To be able to delete a light source, you must have more than one source.

Light Source Groups

Light sources can be grouped together to help organize the list of light sources. Light source groups also allow you to enable or disable all of the light sources within the group with a single click by clicking on the **Enabled** column next to the group in the list of light sources.

Create a new group by clicking on the  **New group** button.

To place a new light inside this group, click on the group on the list, then click on the  **New light** button.

To place an existing light inside this group, select the light you want to move by clicking on it in the list. Drag and drop it on the group where you would like to place it.

Groups of light sources may also contain other groups.

Properties common to all types of source

To modify the properties of a light source, click on it to select it in the list of lights or in the viewport. When selected, a light source's representation in the viewport is highlighted in yellow.

The **Light Sources** box lists the properties of the selected light source.

Check the box beside the light's name to enable the light source. A disabled light is visible in the 3D view in black, but casts no light.

Adjusting the Light Source's Properties

Lighting Settings

The light source's name is displayed in the text field next to the activation checkbox. Type a new name to modify it. Validate your changes with the **Enter** key.

- The **Type** drop-down list allows you to change the type of light source.



NOTE

The attenuation for light sources of type **Spot**, **Omni**, and **Area** can be modified. To improve performance, the contribution of a light can be canceled at a certain distance from the light source with the parameters **Full Effect** and **Falloff** available in the **Attenuation [305]** collapsible box.

- The **Filter Surfaces** button beside this drop-down list allows you to set up a list of surfaces to include or to exclude for the selected light source. This button opens a new window in which you can select the **Type** of list (surfaces to **Include** or to **Exclude**) and the mode, which allows you to apply the inclusion or exclusion to **shadows** only, to **illumination** only, or to **both**. Below the filter type choices are two columns listing all surfaces of the model on the left and the list of surfaces to include or exclude on the right. Select surfaces by clicking on them in the list. Then, use the buttons between the lists to move the selected surfaces from one list to the other.
- **Color**: Click on the colored square to open the color chooser and select a different color.

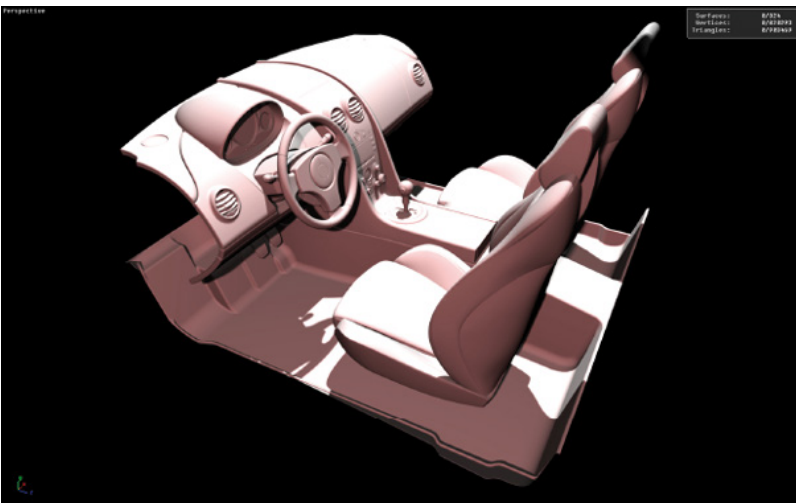

Color change visible in the instant preview of Shaper.

- **Intensity**: Modify the intensity by entering a value in the input field and pressing Enter. Decimal values greater than or equal to 0 are accepted. The default value is 1.

Shadow

Shadows are cast by default by light from a light source. Unchecking the **Cast** checkbox disables shadows for the selected source. If shadows are enabled, the intensity and integrity of shadows can be adjusted:

- **Intensity:** The higher the value, the lighter and more attenuated the shadows will be. The intensity must be a decimal value greater than or equal to zero. Use the **Enter** key to validate any changes.
- **Integrity:** Choose an integrity from the drop-down list. Integrity values range from **Weak** to **Max**. Higher values increase shadow quality and shadow calculation time.

Attenuation

The **Type** list adjusts the speed at which the intensity of light changes, applied between the full effect distance and the distance where the contribution becomes zero. You can choose from fast or slow options for both linear and quadratic speeds. Additionally, you can select **None** for no change or **Physical** for a more realistic effect.

By activating **Bounded** attenuation, the following settings are available:

- **Full Effect:** distance from the source for which the surfaces are illuminated without light attenuation.
- **Attenuation:** this is the distance to light beyond which the surfaces are no longer illuminated.

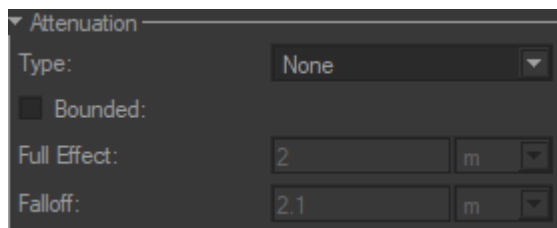

Attenuation collapsible box.

In **Preview** mode, the attenuation gizmo indicates the full effect and falloff distances. It is activated by checking the **Preview Bounded Attenuation** check box. The surface parts illuminated without light attenuation are displayed in red. The surface parts illuminated with light attenuation are displayed in pink.

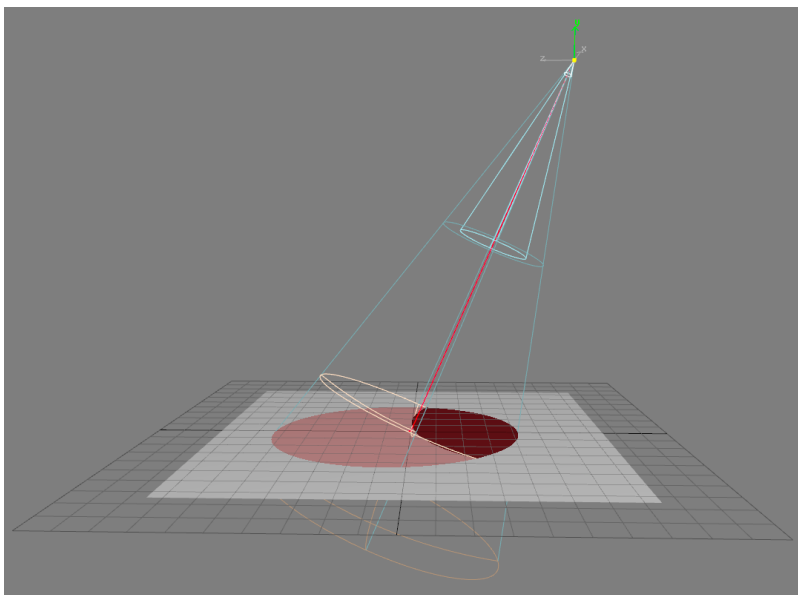

Attenuation gizmo. The sphere parts represent the full effect distance and the falloff distances.



IES Light Profile

Light sources of type **Spot**, **Omni**, and **Area** can accept an IES profile. The IES profile describes the physical properties of a light source. In the floating window, select an IES profile from your computer, then click the **OK** button. The profile will be activated automatically. If you wish to deactivate the profile, simply uncheck the corresponding checkbox.



Positioning Light Sources

Light sources can be positioned individually or in groups.

Translating a Light Source

1. Select the light.
2. Enable the **Translation gizmo** .
3. For a manual modification: hover over the gizmo to make the pointer change to four white arrows. Then, move the light source by dragging the mouse while holding down the left button.
4. To modify according to exact values: enter relative  or absolute  coordinates in the dialog box.

Modifying the Orientation of the Source



1. Select the light.
2. Enable the **Rotation gizmo** .
3. For a manual modification: hover over the gizmo to make the pointer change to a white rotating arrow. Then, orient the light source by dragging the mouse while holding down the left button.
4. To obtain a modification according to exact values, enter relative  or absolute  coordinates in the dialog box.

Making the Anchor Point of the Light Source Coincide with the Viewport

1. Select the light.
2. Orient the viewpoint of the 3D window so that the viewport would be looking directly into the light in its desired position.
3. Click on the **Align the light on the camera**  icon. The light is aligned to point to the camera.

Positioning a Selection of Multiple Light Sources

Two modes exist for applying transformations to a selection of lights:

Icon	Function	Description
	Transform selected surfaces using the pivot of the leader selection	The transformation is applied to all selected lights relative to the pivot of the selection leader (whose gizmo is displayed in white).
	Transform selected surfaces using their own pivot	The transformation is applied to all lights in the selection relative to their own pivot.

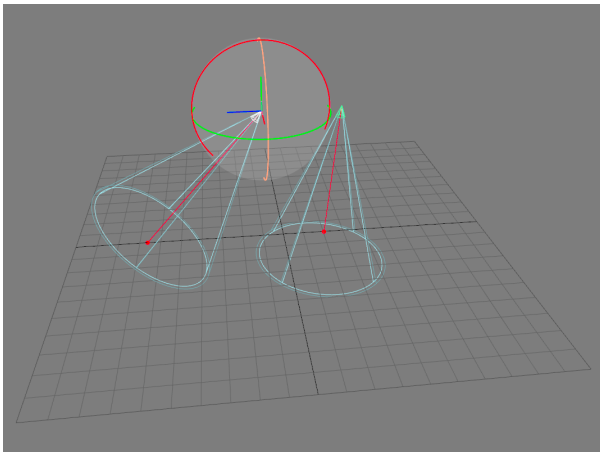

A selection of two lights. The light selection leader's gizmo is displayed in white.

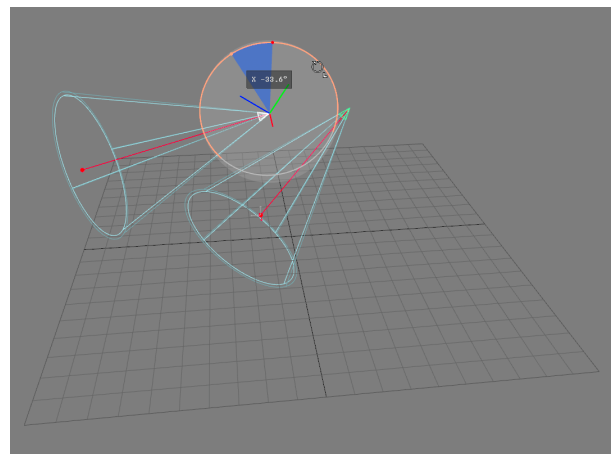
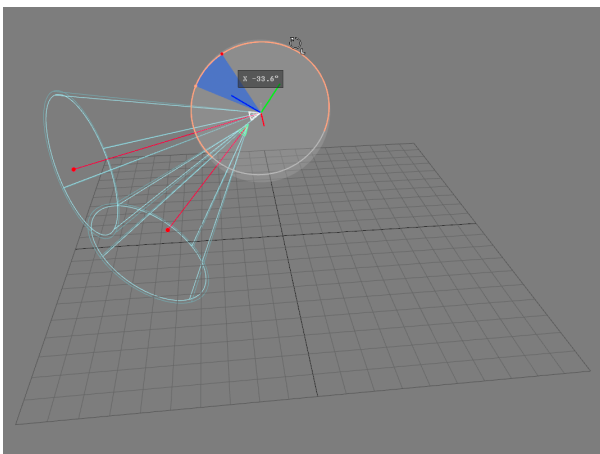

A rotation is applied to a light selection relative to the selection leader's pivot (left) or relative to the lights' individual pivots (right).

Properties of Sky Sources

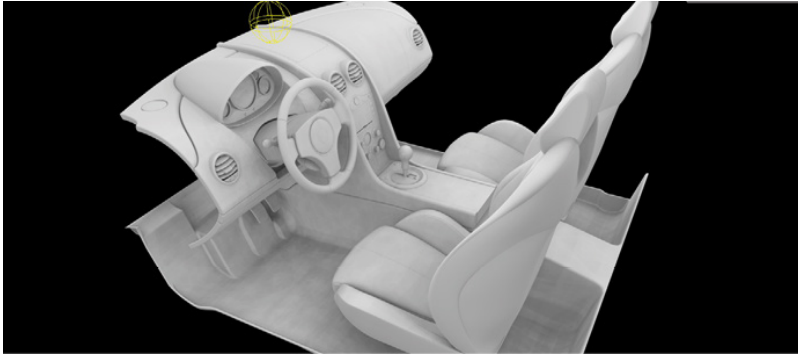

Parameters specific to the **sky** light source:

- A **Sky angle top**: value between 0 and 90 degrees.
- **Sky angle bottom**: value between 0 and 90 degrees.
- **HDR environment**: allows an HDR image to be loaded, which will tint the lighting color generated by the sky.

Properties of Spot Sources

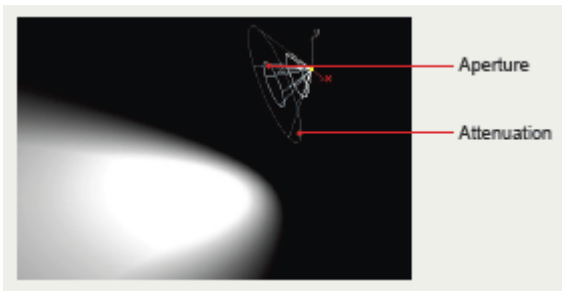

Parameters specific to the **spot** light source:

- **Attenuation**: angle of aperture of the spot, value between 0 and 175 degrees.
- **Aperture**: angle of aperture of the intensity zone, value between 0 and 175 degrees.
- Choose one of the items from the attenuation type list: **Slow linear attenuation** , **Rapid linear attenuation** , **Slow quadratic attenuation** , **Rapid quadratic attenuation** , **Physical attenuation** .

Gizmos for Aperture and Attenuation Cones

The spot light gizmo involves a target point. This target point is located on the symmetry axis of **Aperture** and light **Attenuation** cones.

The target point of the spot has its own translation and rotation gizmos, which simplifies its positioning. The spot light source orientation is updated during the movement when the translation and rotation gizmos are used.

Translation gizmo: a normal translation gizmo is attached to the target point.

Rotation gizmo: manipulating the rotation gizmo of the target point moves this point the same way manipulating the rotation gizmo of the light source would.

Positioning a spot light directly using its own gizmos is still possible.

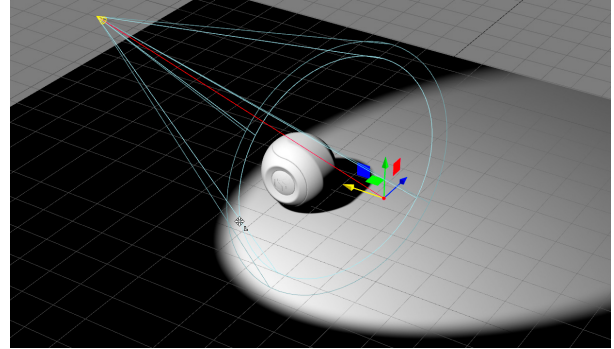
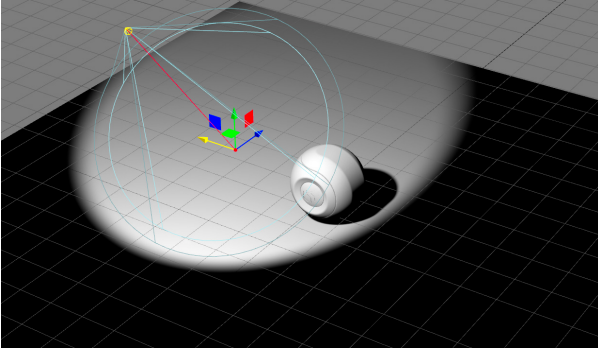

Moving the target point of the spot light using the translation gizmo.

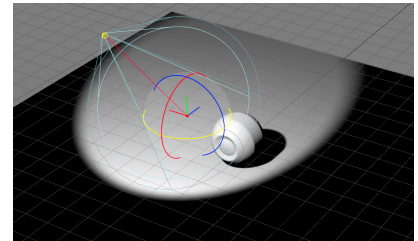
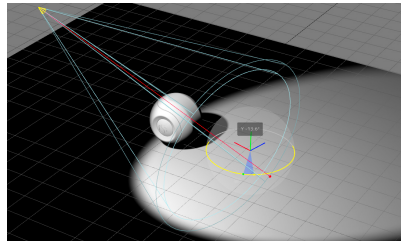
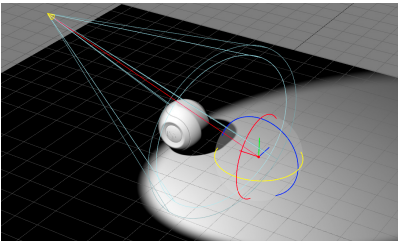

Moving the target point of the spot light using the rotation gizmo.

It is also possible to move a source and a target simultaneously by clicking on the blue part of the gizmo.

Properties of Sun Sources

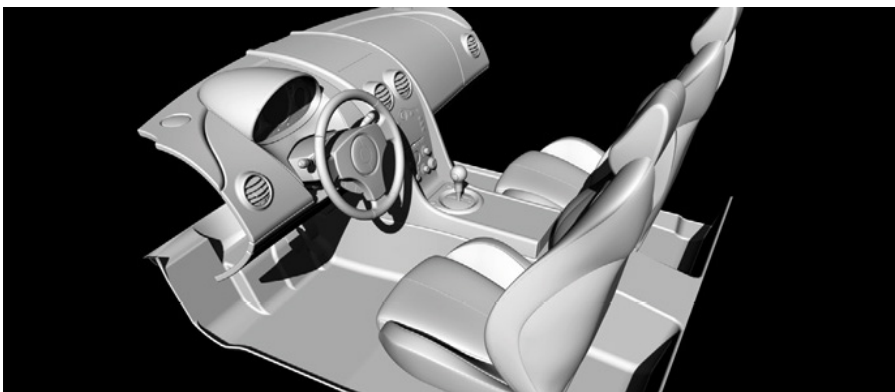

A **Sun** type light source is a light with infinite directions, whose beams are parallel.

1. Fill in all the input fields.
2. Choose one of the **Attenuation type** list items.

Properties of Omni Sources



An **Omni** type light source is omnidirectional, which illuminates all around itself.

1. Fill in all the input fields.
2. Choose one of the **Attenuation type** list items.

Properties of Area Sources

In the case of area light sources, light is emitted from any surface chosen by the user. Since pre-existing meshes can be used, lighting creation becomes intuitive. Moreover, even if no dedicated meshes are present in a scene, specific primitives that can be modified on the fly are provided to simplify lighting creation.



Example of render involving area lights.

To add a surface light to your scene, create a new light and select **Area** in the **Type** drop-down list.

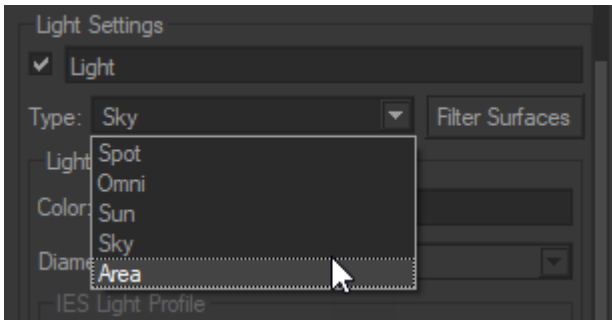

Selection of the Area light type.

The surface geometry to use as a light source is specified in the area lights parameters box of the **Lighting** tab using two methods.

- If a dedicated mesh already exists, it is set as a light source geometry by first selecting **Mesh** as an area light type (default), then by enabling the function **Pick Surface**  before selecting the surface directly.

The name of the surface linked to the areal light is then displayed in the areal light parameters box.

- If no dedicated mesh exists, specific predefined primitives (planes and cylinders) whose dimensions can be updated on the fly can be used.

The translation and rotation gizmos and the **Align Leader Light to Camera** function  can be used to move and orient these primitives.

In both cases, the light is emitted according to the surface normals.

Lighting Planner

The Lighting Planner provides an advanced method for baking the illumination of a scene when using lightmaps. In the simple baking scenario, the layers and the surfaces to light can be selected, but lighting is calculated in a single step. Using the Lighting Planner, lighting can be calculated in as many steps as necessary.

The advantage of multiple-step calculation is the variety of lighting scenarios that can be calculated, which makes it possible to use lightmaps to light scenes containing animations or multiple geometry positions.

Planning a Lighting Sequence

To access the lighting planner, make sure you are in the **Lighting** tab in the **Shaper** interface.

1. Set the rendering **Mode** to **Lightmap**.
2. Modify the **Baking scenario** by choosing the **Advanced** option.
3. Click on the button .

Once a sequence has been defined, close the Lighting Planner and calculate the lightmaps normally.

Lighting Layer

Create a step by selecting the lighting layer:

1. Click the **Add Step** button.
2. Select the lighting layer you want to use from the context menu that appears.

You can add as many steps as necessary. You can also:

- Delete steps that you do not want to keep,
- Rename steps.

Steps will be calculated one by one starting at the top of the list.

It is possible to modify the layer targeted by a step at a later moment:

1. Select a step in the list.
2. Modify the selected layer in the **Target layer** drop-down list.

Configuration

For the selected step, assign a set of configuration parameters. Lighting, geometry, and position layers will have an influence on the lightmaps that will be calculated.

Button	Description
Acquire	Apply the configuration that is visible in the active viewport to the active step in the Lighting Planner.
Set	Apply the configuration for the active step in the Lighting Planner to the active viewport. This is one way to verify that the chosen configuration parameters correspond to the desired model configuration.

Part Animator

For the selected step, assign a position to the moving parts of the kinematics hierarchy. The sliders available in the **Animation Sliders** editor are available within the Lightmap Planner. Move the sliders to set kinematics positions.

Button	Description
Acquire	Apply the kinematics positions that are visible in the active viewport to the active step in the Lighting Planner.
Set	Apply the kinematics positions for the active step in the Lighting Planner to the active viewport. This is one way to verify that the chosen kinematics positions correspond to the desired model state.

Selected Surfaces

For the selected step, choose the surfaces that should be lit.

Button	Description
<i>Acquire</i>	Apply the surface selection that is visible in the active viewport to the active step in the Lighting Planner.
<i>Set</i>	Select the surfaces the list in the Lighting Planner in the active viewport. This is one way to verify that the correct surfaces have been selected for this step.
<i>Clear</i>	Clear the list of selected surfaces.

DISTRIBUTED LIGHTMAP RENDERING

Depending on the hardware configuration in use, lightmap rendering can be performed either locally or on a networked set of computers. Distributing the rendering to a networked set of computers will significantly reduce the time required for rendering lightmaps.

The lightmap rendering mode is selected in the **Lighting Tab** in the Shaper sidebar. The **Tools** box is displayed when the selected **Lighting Type** is set to **Lightmap**.

Start Local Rendering is used to render the lightmaps locally. Local lightmap rendering is based on the use of the processor and graphic cards of the computer on which Patchwork 3D is executed.

Start Distributed Rendering is used to render the lightmaps on the rendering machines running Patchwork Lightmap Render.

Patchwork Lightmap Render

Installing Patchwork Lightmap Render

Install the Patchwork Lightmap Render software on the computers you wish to use for distributed rendering.

This application must be run manually in order to provide the distributed rendering service. If you restart Windows on one of the computers functioning with Patchwork Lightmap Render, you must also restart the Patchwork Lightmap Render application.



WARNING

If you have installed Patchwork Lightmap Render on computers that are listening for a render task, but which aren't found by Patchwork 3D in the unit discovery window, verify that no network agents are set to block discovery broadcast packets.

If you do not have access to the network configuration in order to disable broadcast filtering, you can manually enter the name or the IP address of the Patchwork Lightmap Render machines.

How Patchwork Lightmap Render Machines Work ?

Should the Patchwork Lightmap Render application crash, it will restart itself automatically.

A Patchwork Lightmap Render machine can only participate in a single rendering session at a time. If another instance of Patchwork 3D sends a request for the computer's availability while it is already participating in a render session, the Patchwork Lightmap Render machine will send back the status "Busy." Patchwork 3D will continue to attempt to open a session at regular intervals until a session is opened or the rendering is completed on the available machines.

Distributed Lightmap Rendering Mode in Patchwork 3D

The distributed lightmap rendering mode uses resources from several computers running Patchwork Lightmap Render. The Patchwork Lightmap Render software must be set up and run on the computers you want to use. The same applies to the computer on which Patchwork 3D is installed if you wish to use it for distributed rendering.

Setting up the Distributed Rendering

The port used for finding the Patchwork Lightmap Render computers is specified in the **Settings**. Browse to **File > Settings > Lighting tab > Distributed lightmap rendering box**.



NOTE

The default UDP port for finding Lightmap Render Units is 4242. Enter another value if required.



TIP

In order for a rendering unit to be discovered by Patchwork 3D, the port number used for discovery must be the same as that of Patchwork 3D.

Clicking on **Start Distributed Rendering** displays the **Distributed lightmap rendering configuration** window, dedicated to management of Patchwork Lightmap Render machines.

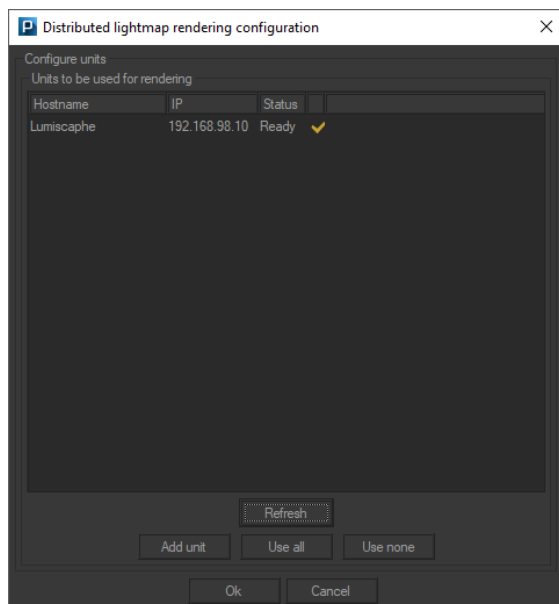

Distributed Lightmap Rendering Configuration window.

If your network infrastructure allows it, Patchwork Lightmap Render machines are automatically found by broadcast. They appear directly in the list of known Patchwork Lightmap Render machines.

The following data is displayed for each of the known Patchwork Lightmap Render machines:

- The name of the host computer on which the Patchwork Lightmap Render software is running,
- The IP address of this computer,
- The status of the Patchwork Lightmap Render machine – the various statuses are detailed thereafter,
- A checkbox specifying whether a Patchwork Lightmap Render machine is selected for the rendering.

The various statuses of the Patchwork Lightmap Render machines are the following:

Status	Description
Available	The computer is ready to perform a rendering.
Busy	The computer is being used by the Patchwork 3D software on the specified computer.
Disconnected: connection denied	The Patchwork Lightmap Render program is not currently running on the machine.
Disconnected: host not found	The host computer cannot be found on the network – the rendering machine might not be turned on.
Disconnected: incompatible protocol version	The version of the Patchwork Lightmap Render software is not compatible with the Patchwork 3D version used. Patchwork Lightmap Render must be updated.

Some network infrastructures do not allow automated discovery of Patchwork Lightmap Render machines. In that case, the units need to be added to the list manually. In order to do this, click on **Add unit**. Next, enter the name of the computer you want to use. The computer is now displayed in the list. The asterisk added to the name of the computer specifies that this machine has been added manually. The Patchwork Lightmap Render software must already be installed on any computer you wish to add manually as a Patchwork Lightmap Render machine.

The list of available machines is updated with the **Refresh** button.

The buttons **Use all** and **Use none** allow the user to select all or none of the units, respectively.

To delete a machine added manually from the list, select it and click on **Remove unit**.

Exiting the **Distributed Lightmap Rendering Configuration** window is possible at any time by clicking the **Cancel** button. The list of manually added machines and their state of use during the latest rendering are saved on exit.

Starting a Distributed Rendering

Once the Patchwork Lightmap Render machines have been set up, start the lightmap rendering by clicking the **Ok** button.

At the start of a distributed rendering, allowing the connection with the Patchwork Lightmap Render machines through the firewall of your Windows OS may be required.

The lightmap rendering progression window displays a progress bar, the estimated remaining time, the elapsed time since the beginning of the rendering, the count of surfaces for which the rendering has been completed, and the status of the rendering.

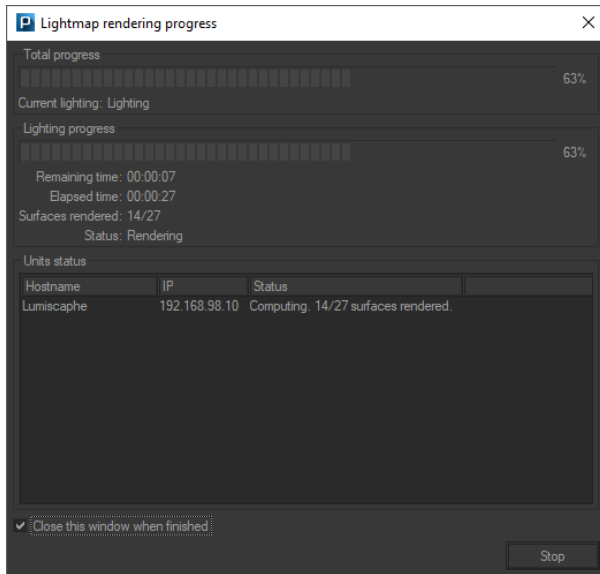

Lightmap rendering progress monitoring window.

The status of each rendering machine is also displayed. Several statuses are possible:

Status	Description
Transferring data	Transferring data to the rendering machine.
Initialization	Initialization of the rendering machine.
Computing	Lightmap rendering in progress.

The window closes automatically when the rendering is over if the **Close this window when finished** checkbox is checked.

Stopping Distributed Rendering

The rendering in progress can be stopped at any time by clicking the **Stop** button. A window opens to offer you the choice of how to proceed:

Option	Description
Continue	Restart the calculation of the illumination for the remaining surfaces. Data may be transferred to the rendering machine.
Keep	Abandon the calculation for the remaining surfaces, but display the illumination that has already been calculated.
Discard	Abandon the calculation for the remaining surfaces and do not display the illumination that has already been calculated. This option will restore the previous illumination.

During the rendering, the model's surfaces whose lightmap is being rendered are displayed in white and in wireframe mode. Surfaces whose lightmap has not been rendered yet are displayed in red. Once rendered, a lightmap is displayed on the model.

Resources Consumed

A Patchwork Lightmap Render machine listening for requests for rendering consumes no system resources.

During a render session, a rendering machine calculates lightmaps from the geometric information concerning all of the visible surfaces. In order to optimize the render speed, all of the surfaces are stored in the GPU. Then, the lightmaps are calculated one by one at Patchwork 3D's request.

The resources of a rendering machine that can be used by Patchwork 3D are only limited by the hardware configuration of the machine.

For a standard Patchwork 3D model, containing between 3 and 5 million triangles for 300-500 surfaces, the GPU consumption is about 2 GB. The consumption of RAM resources is approximately identical to the GPU consumption.

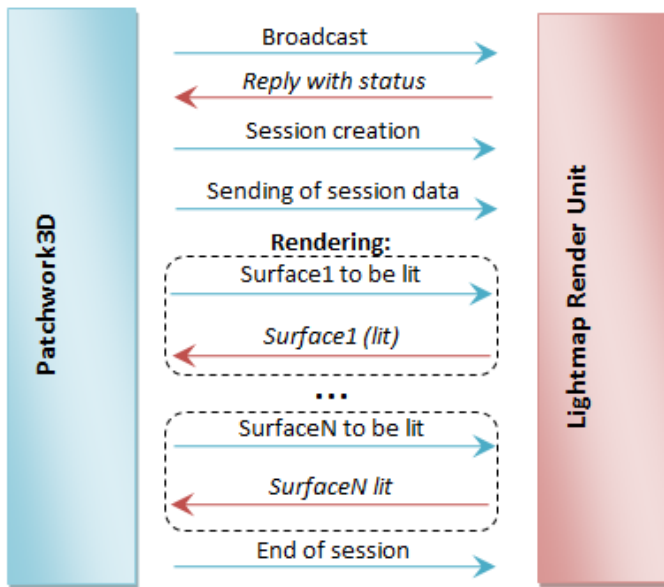

Network events between Patchwork 3D and a Patchwork Lightmap Render machine.

For a standard Patchwork 3D model, the following illustration represents a typical resource consumption:

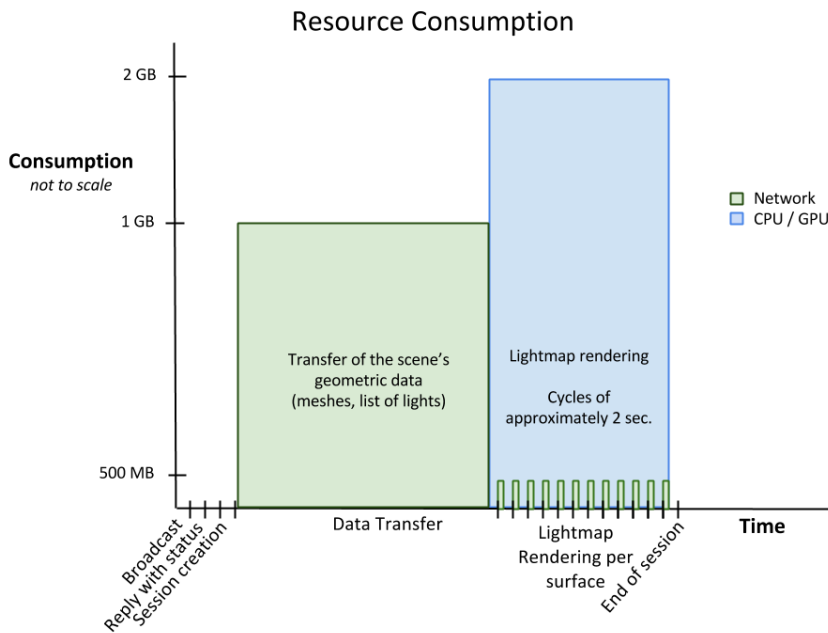

Behavior Following Loss of Connection

Loss of Network Connection

Patchwork 3D and the Patchwork Lightmap Render machines will automatically detect the loss of a network connection.

Patchwork 3D will redistribute the render calculations left to perform to the rendering machines that are still connected. Patchwork 3D will continue to attempt to reconnect with the rendering machines that were disconnected.

If no machines are connected, Patchwork 3D will continue to try to reconnect with the Patchwork Lightmap Render machines at regular intervals. During this time, the rendering is paused. You may choose to cancel the rendering at this point. You may either save or dismiss the results for the surfaces for which lighting has already been calculated.

A rendering machine that has lost its connection to Patchwork 3D becomes available on the network. It will accept the first session request that it receives from an instance of Patchwork 3D looking for a machine running Patchwork Lightmap Render.

Patchwork 3D Crash

A crash of the Patchwork 3D application will break the connection with the Patchwork Lightmap Render machines.

A rendering machine that has lost its connection to Patchwork 3D becomes available on the network. It will accept the first session request that it receives from an instance of Patchwork 3D looking for a machine running Patchwork Lightmap Render.

PRODUCTS

A product is a geometrical model that is or can be dressed. Once dressed, a product is used in producing synthetic images for design purposes. Its general appearance is obtained by assigning a photorealistic material (wood, leather, gold, plastic, etc.), by inserting it into a complex lighting environment (photo studio, forest, industrial environment, desert, etc.), and by adding effects such as backgrounds, post-processing, and overlays.

Products are managed from the tab  **Products** from the sidebar of **Matter**.

Product Library

For this library, organization by model is mandatory. Models are created in **Shaper**. The **Create** and **Duplicate** operations for models are not available in **Matter**.

Some product thumbnails may appear with an  icon. This indicator means that the image shown in the thumbnail no longer corresponds to the current representation of the product. The thumbnail will be recalculated and the indicator will disappear the next time you finish editing the product. Thumbnail images are updated either at the time the file is saved, or as a background task in order to maintain the smoothness of movement needed for correct functioning of the **Matter** module.



NOTE

Patchwork 3D allows you to memorize **4 favorite cameras [444]** per product. If **favorite camera 1** is defined, it is then used as the viewpoint for calculating the thumbnail. Otherwise, the thumbnail will be calculated when you close the last viewport or viewport tab in which the product was active, using the camera viewpoint from that viewport.

Product Properties

Surface Visibility

This property defines the strategy used to obtain the visibility of surfaces in a product. The inactive box indicates that a surface visible in **Shaper** is visible in **Matter**. The enabling this option breaks this dependency, and each surface will have its own visibility attribute. This property can be edited in the product properties.

Environment

This property allows you to define the environment used to place the product in a setting (photo studio, exterior scene, etc.). If the value of this property is not initialized the environment used for the rendering is a neutral environment (default behavior). It is recommended to create new materials using this environment, as it does not influence the perceived color.

Assigning an environment is accomplished with a drag-and-drop from the sidebar environment library to the interactive zone of the viewport. To return to the default environment, open the menu item **Editors > Product Environment**, then select the environment in the **Environments** box and apply the operation, **Remove the environment**.

Background

Standard Assignment

You can use several types of backgrounds to simulate an environment in which your product is placed. Backgrounds are applied to camera sensors.



From left to right: None – Gradient – Environment.

The type of background can be selected under the menu **Camera > Background**.

The assignment of a background is performed by:

- Drag-and-drop from the **Matter** sidebar's background library to the **Sensors** editor or to the interaction zone of the viewport,
- Drag-and-drop from the **Backgrounds** editor to the **Sensors** editor or to the interaction zone of the viewport.

An operation for removing the background from a camera's sensor is available from **Camera > Background > Remove Background**.

For more information on backgrounds, see [Backgrounds \[381\]](#).

Background and Environment on Product Selection

This function enables you to assign a background to a product in the designated viewport or to several products save considerable time.

This command offers you three modes of product selection:

- All the products in viewports,
- All the products of the model,
- All the products of all models.

This operation is performed by dragging and dropping the background from the **Matter** sidebar's background library into the active viewport while holding down the **Ctrl** key.



TIP

The information line located at the bottom of the active view indicates the function of this command: ***[Ctrl ="Product selection dialog"] Set background to XXXXXXXX.***

These assignment modes can only be performed on environments and overlays.

MATERIALS

A digital material, like a physical material, is the source of a surface's visual aspect. The materials in your database reproduce the visual properties of the physical materials that they represent.

Each surface is assigned a material. In some cases, a surface can be dressed with multiple materials. This is the case when you apply stickers or when you make use of aspect layers.

Patchwork 3D allows you to change the aspect of your product in real-time by assigning new materials to a surface. No calculation is carried out, but the product is updated instantly while you continue navigating around it in the 3D world.

Seven types of material exist. A type is defined by the function of the surface to which the material is assigned:

Material type	Use
Standard	The default material can duplicate most types of physical materials using two layers, a diffuse layer and a reflective layer.
Environment	This material represents the environment of a scenario. It is used to dress a skydome, which is a hemisphere surrounding a product.
Matte	This material only shows the shadow of a product. When assigned to a plane on which your product is placed, it increases the realism of the scene when your scenario consists of a simple 2D background.
Mirror	This material is used to dress surfaces in which the reflection of other surfaces in the scene are visible.
Multilayer	This material is designed for the advanced user. Its precision is useful for creating complex and detailed materials.
Seam	This material is used to represent the particularities of a sewn seam.
Sticker	All standard materials can be assigned as stickers, but this type of material is designed specifically for that use. It can therefore be employed with another material on a single surface, or even assigned several times to the same surface. This can be useful in the case of certain patterns such as stickers, printed marks, engravings, stamps, or other marks that aren't part of the aspect of the physical material itself.

The Patchwork 3D materials are managed from the **Matter** sidebar's material library.





Their settings, including their colors, can be modified via [Materials \(Editor\) \[196\]](#).

The [Positioning and Orienting Materials \[366\]](#) describes the two manipulation modes used to interactive-ly position and orient materials.

Material Library

In the **Matter** sidebar's  library tab, the  material library manages the groups of materials and the materials available in your database.

Groups of materials are listed in the upper part of the library:

Icon	Description
	Create a new group.
	Duplicate the selected group.
	Rename the selected group.
	Delete the selected group.





Double-clicking on the material thumbnail makes it active and opens the materials editor.



TIP

To quickly locate the material in the library you can use the keyboard shortcut **E** when the mouse cursor is over a material. You can also use the shortcut **Shift + E** to directly open the materials editor.



The list of materials shows all of the existing materials in the selected group. Using the buttons below the list, you can:

Icon	Description
	Create a new material.
	Duplicate the selected material.
	Edit the selected material by opening the Materials editor.
	Rename the selected material.
	Import materials. KMT and AxF formats are supported. KMT format is supported.















NOTE

AxF [326] file import (SVBRDF or CPA2 types) is subject to a license option.



	Export selected materials in KMT format or AxF.
	Delete the selected materials.
	Purge materials that have not been used (materials that are not applied to any surface of any product).

Icon	Description
	Modify the way in which the list is displayed.

Right-clicking on a material opens a context menu offering the following options:

Icon	Function	Description
	Set active	Make the material you have clicked active and shows it in the lower part of the library.
	Edit	Edit the selected material by opening the Materials editor.
	Duplicate	Duplicate the selected material.
	Convert to multilayer material	Convert the selected material(s) into equivalent multilayer materials.
	Replace with	Replace the selected material(s) with another material from the material library.
 NOTE This functionality is available if at least two materials already exist in the material library.		
	Rename	Rename the selected material.
	Usage list	Show a list of all products in which this material has been applied.
	Import	Import materials. KMT and AxF formats are supported. KMT format is supported.
 NOTE Importing the file AxF [326] (SVBRDF or CPA2 type) is subject to license.		
	Export	Export the selected materials in KMT or AxF formats.
	Delete	Delete the selected materials.

The active material is shown in the lower part of the library:

Icon	Description
Thumbnail	Double-clicking on the thumbnail opens the Materials editor.
	Use the eyedropper to pick a material from a surface in a viewport and render it active.
	Open the Materials editor for the active material.
	Select the active material in the list of materials.

AxF Material

AxF is a file format that encodes digital material representations, including those of materials measured using X-Rite material scanning technologies. Patchwork 3D supports version 1.9.0 of AxF files.



NOTE

Please note that AxF CarPaint (CPA2) type files can be exported in AXF format if they are not modified. If they are modified, only the export in KMT format is supported.



WARNING

Overriding a material with an AXF type file consumes a lot of GPU and RAM memories.

You can change the base color of an AxF (CPA2) material from **Matter** by right-clicking on the surface that has an AxF material or from the **Materials Library** by right-clicking on the AxF material.

The parameters to be adjusted are as follows:

- **Hue Shift**
- **Saturation**
- **Exposure**
- **Contrast**



NOTE

Please note that these parameters are relative to the original color of the material. A saturation of 1, for example, corresponds to the original color of the AxF, if you decrease this value it decreases the saturation and if you increase this value it increases the saturation. The reasoning is the same for the other parameters.

Standard Material

A **Matter** standard material allows you to simulate materials such as metal, wood, plastic, stone, paint, etc.

A standard material is designed to reproduce the characteristic behavior of a material immersed in a lighting environment. It is above all a visual simulation, in the field of perception.

The settings of a standard material are take into account the elements that define of the matter, i.e. the color and pattern, capacity to reflect or tint the environment, surface texture, transparency, and behavior during rendering by raytracing.

A standard material is broken down into a **Diffuse** coat, or layer, over which a **Reflection** layer is applied, each of which may be textured. The interaction between the two layers allows most materials to be simulated realistically.

The **Matter** module offers standard materials belonging to the following classes:

- **Diffuse** only: The material has color, pattern, and texture attributes, but does not reflect the environment. The reflection settings are not available.
- **Diffuse and Reflection**: The material has color, pattern, and texture attributes, and it reflects or tints the environment.
- **Transparent Filter**, or reflection layer only: The color of the material serves as a transparent filter. The material can be textured and reflects or tints the environment. The diffuse settings are not available.

Basic Principles

In order to give you an idea of the characteristic features of a standard material and to introduce the parameters associated in **Matter**, here is the breakdown of a slightly reflective fabric.

To replicate the appearance of a photorealistic material, the **Matter** module proceeds by layer:

- **Diffuse**: When created, a new material is slightly gray and has the appearance of perfectly smooth rubber.
 - **Color and pattern**: The Color Map field is used to apply a pattern mimicking fabric fibers.
 - **Texture**: In the **Bump** tab, the **Bump Map** zone encodes the surface texture used to simulate the unevenness of woven fabric. The depth of this unevenness is modulated by the **Diffuse Depth** setting.
- **Reflection**: The overlay of a reflection (type Diffuse and Reflection) without taking into account the unevenness of the texture on the reflective layer simulates a thin film of plastic on the fabric.
 - **Color**: A reflective layer has a tendency to lighten the material.
 - **Texture**: Final, to finish the material, enable and set the **Reflection Depth** in the **Bump** tab.



Diffuse layer



Diffuse layer + color



Diffuse layer + diffuse texture

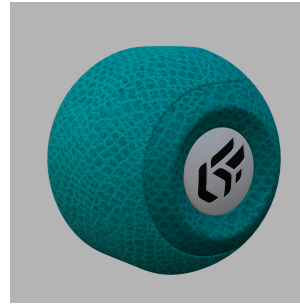

Diffuse layer + color and pattern + diffuse texture

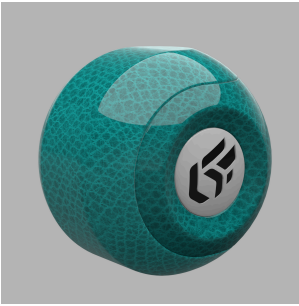

Diffuse layer + color and pattern + diffuse texture + reflection

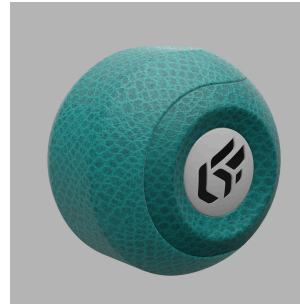

Diffuse layer + color and pattern + diffuse texture + reflection + reflection texture

Diffuse

Light does not pass through a diffuse layer. Light is either absorbed, or returned to the eye of the observer. The **Diffuse** tab groups the settings related to this diffuse layer.

Diffuse Color

The color of the diffuse layer is influenced by several settings: the color **Filter**, the lighting environment conditions, the **ambient** color, and the **illumination** color, among others.

The color **Filter** setting corresponds to the color perceived when the material is lit by white light. As the material reacts like a filter, it reflects part of the light it receives. The perceived color of an object is thus greatly influenced by the lighting environment. If we consider that white light is made up in equal parts of green, red and blue (empirical computer model), then a black body absorbs all these components, a white body reflects them without alteration, a red body absorbs the green and blue, etc.

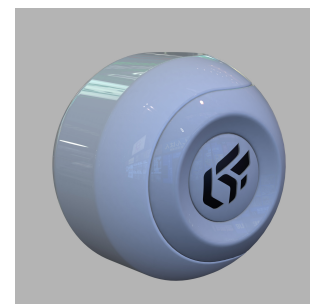

Influence of the lighting environment conditions on the color of a material.

The creation of a new material should thus imperatively be performed in a neutral light environment, for example, the default environment in the **Matter** module.

The parameter **Intensity** allows you to amplify or attenuate by a multiplicative factor the effect of the light environment on the material.

The **Ambient** color parameter allows you to add a constant color. It is common practice to add a light gray to lighten a material. However, we would advise you to limit the amount of ambient light since a material of relatively dull appearance originates from a relatively dull environment.

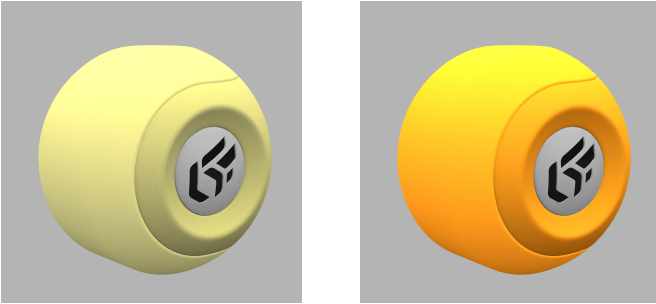

The effect of an ambient color on the appearance of a yellow material. Left: gray ambient color. Right: red ambient color.



The effect of an illumination color on the appearance of a yellow material. Left: ambient gray color + blue illumination color. Right: ambient color red + illumination color blue.

Color Map

Some materials have a pattern or motif that is created by repeating or not an image across the surfaces to which the material is assigned. The **Color Map** settings are used to assign, resize, and position the first instance of such an image.

Color maps are image or video textures. To use a texture as a color map, drag it from the sidebar texture library and drop it in the **color map** zone. To be shown, the color map must also be enabled by ticking the checkbox next to the color map zone.

The texture dimensions are used by default for an image texture.

For a video texture, the longest edge of the format is scaled to one meter by default. The format's aspect ratio is respected. Any texture used as a color map will repeat.

You will find in the collapsible box named **Mapping** the following parameters **Allow repeat in U** and **Allow repeat in V**, which allow you to choose to repeat the texture in U and/or V. By checking the **Mirrored** checkbox, you can reflect the texture in U and/or V.

Reducing moiré on high-frequency textures

Available in: **Matter** > **Material Library**  > material > **Diffuse** > **Color Map** > **Resolution offset**

Principle

The **Resolution offset** parameter deliberately reduces the sampling level to eliminate moiré on dense patterns (houndstooth, tweed, technical weaves), at the cost of lowering the perceived detail.

The setting can vary from -15 to 15 to control the level of detail of the textures shown.

- Negative values (e.g., of **-1** to **-15**): These values simulate a closer camera. This allows the texture to be displayed in greater detail, making it sharper than it would be by default.
- Value **0**: The default, which displays the texture in its normal level of detail, based on the distance from the camera.
- Positive values (e.g., of **1** to **15**): These values simulate the distance between the camera and the textured surface. This has the effect of making the texture more blurry, as if seen from a distance

In summary, the **Resolution offset** adjusts the sharpness of textures to make them more detailed or blurry, simulating a change in camera distance.



NOTE

It is important to note that this setting does not change the original texture's resolution; rather, it adjusts the level of detail displayed. Negative values can improve perceived sharpness, while positive values can improve performance by reducing detail

When to use it?

To be used for:

Symptom	Action on Resolution offset	Expected behaviour
Visible moiré	Increase the value slightly.	Stable pattern, attenuated interference.
Texture perceived as too soft after adjustment.	Reduce the value and reevaluate at several distances.	Stability/sharpness compromise restored.
Persistent artifacts with sharp angles.	Refine the value and check the result.	Additional reduction in directional flicker.

Adjusting the Resolution offset for Diffuse

1. Starting from the **Material Library** , double-click on the material that needs adjustment to reduce the moiré effect. The **Materials** editor opens.
2. In the **Diffuse** tab, locate the **Color Map** collapsible box and click on the **None** button to open the

Texture Library .

3. Starting from the **Texture Library** , drag and drop the desired texture onto the **None** button.
4. Collapsible boxes **Color Map**, and **Mapping** unfold. In the latter, select the desired value for the **Resolution offset** parameter.
5. Increase the **Resolution offset** gradually until the pattern is stabilized, without superfluous blur.
6. Validate on several angles and distances to highlight a possible Moiré (before and after comparison if necessary).

Media

Use case for reducing the moiré effect on the upholstery of the seat of a chair using the Resolution Offset parameter.

<https://www.youtube.com/embed/G66wFe7kMcY>

Transparency of the Diffuse Layer

The transparency of a standard material of the **Diffuse** or **Diffuse and Reflection** classes can be adjusted directly from **the Materials Editor** using the **Opacity modulator**:

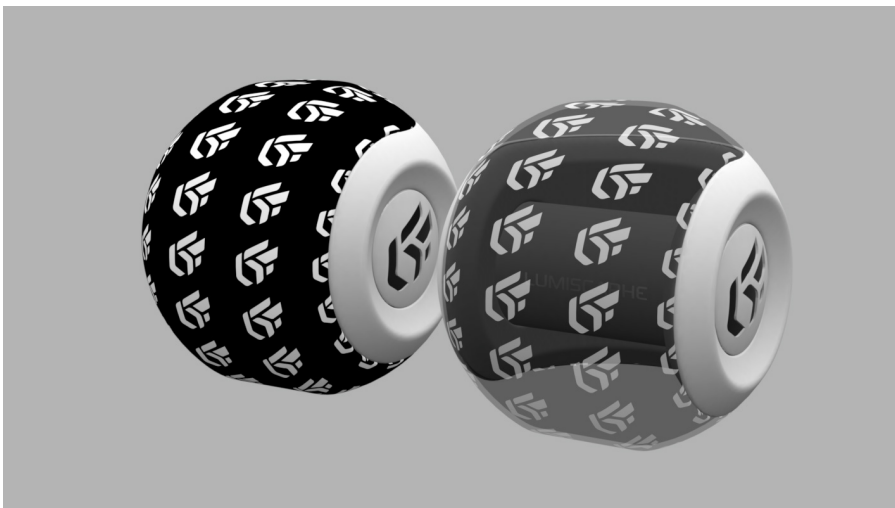

The **Transparency** collapsible box lets you use a texture to control the transparency of the material. The alpha layer contained in the images (PNG format) is used to define the transparency of the texture.

If the texture used as image alpha does not have an alpha channel (JPG image), it is the alpha or the luminosity of the image color map that is used as the alpha channel. In this case, check **Use color map transparency**. The darkest colors correspond to the most transparent areas:

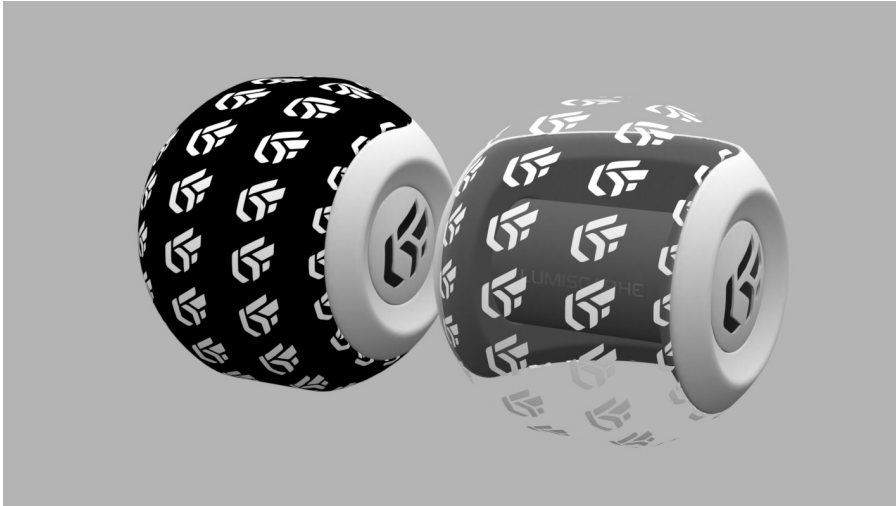

In the collapsible box, you will find **Projection** :



NOTICE

The **Resolution offset** parameter deliberately reduces the sampling level to eliminate moiré on dense patterns (houndstooth, tweed, technical weaves), at the cost of lowering the perceived detail.

The settings of the **Resolution Offset** parameter follow a procedure similar to that described for [Adjusting the Resolution offset for Diffuse \[330\]](#), with the difference that the parameter concerned is in another tab: **Diffuse** with the **Transparency** collapsible box, **Reflection** with the **Specular Map** and **Roughness** collapsible boxes, or **Bump** with the **Bump Map** collapsible box.

- The **Allow repeat on U** and **Allow repeat on V** parameters allow you to repeat the texture on U and/or V. By checking the **Mirrored** checkbox you can reflect the texture in U and/or V.

Filter According to View Angle

Some materials have a color that changes according to the angle of observation. This effect is implemented using a gradient ramp. Click on the **Gradient [188]**  Editor button from the accordion menu called **Advanced** to modify the gradient that is used.

Reflection

The reflection layer is an additive layer. This layer can be used in two ways. When combined with a diffuse layer (**Diffuse and Reflection** class standard materials), it helps to simulate materials that reflect the light of the environment such as metals, varnished woods, smooth or metallic paints, or opaque plastics.

This layer can also be used alone (**Transparent Filter** class standard materials) in order to simulate transparent materials. This transparency is obtained by removing the diffuse layer that blocks the light from passing through the material.

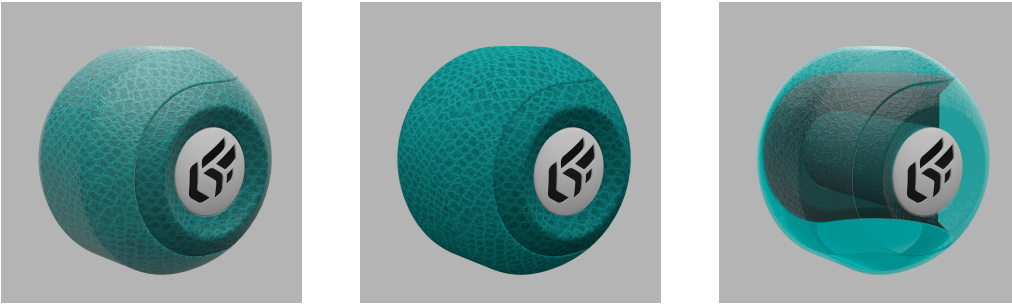

Diffuse+Reflection (left) - Diffuse (center) = Transparent Filter (right)

Intensity

The **Intensity** parameter allows you to adjust the reflection intensity emitted by the material. The **Intensity** value varies in principle between 0 and 1, but a higher value makes it possible to counterbalance a rather dull lighting environment.

A perfect mirror appearance is obtained with the value 1. Even though the color **filter** parameter enables you to attenuate the reflection, we would recommend modifying the **Intensity** value, since it gives access to a more precise adjustment without any risk of coloration.



Variation in the attenuation of the reflection using the Intensity setting, set to values from 1 to 0.005.

Color Filter

The color **Filter** setting in the **Reflection Color** zone is used to tint the reflection. This coloration reproduces the behavior of metals and of certain paints. This parameter may optionally serve to gradually attenuate the effect of the reflection by selecting a filter ranging from white to black.

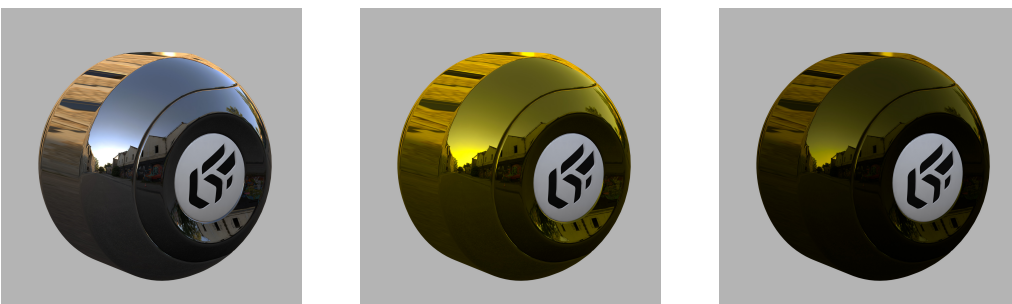

Variation in the Filter parameter.

The Fresnel is an optical effect. The greater the oblique angle at which a glossy surface is observed, the less visible will be the color of the surface, which forms a white reflection.

In the case of a glossy transparent material, the Fresnel will make the surface increasingly opaque the more the viewing angle is reduced.

The calculation of the Fresnel effect in Patchwork 3D is based on the physical formulation of the Fresnel factor to accentuate the photorealistic quality of the rendering.

If no changes appear in the rendering, return to **Shaper** in the lighting module, check that none of the boxes in the illumination cube dialog box are checked.

To produce a material of motor vehicle bodywork paint type, it is necessary to enable the Fresnel effect.

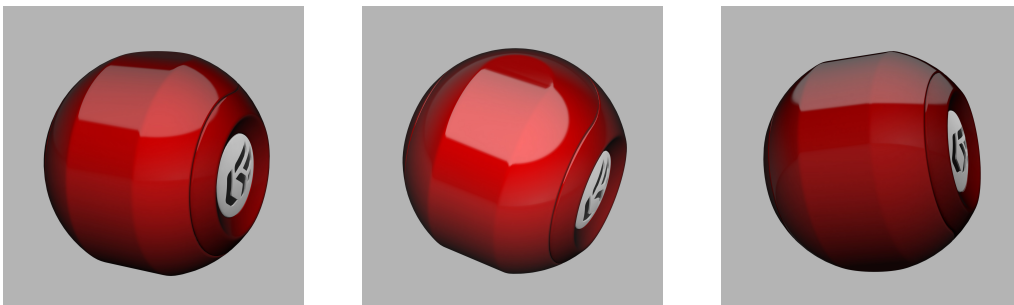

Without the Fresnel Effect: no colorless reflection appears when the product is viewed at a sharp angle.

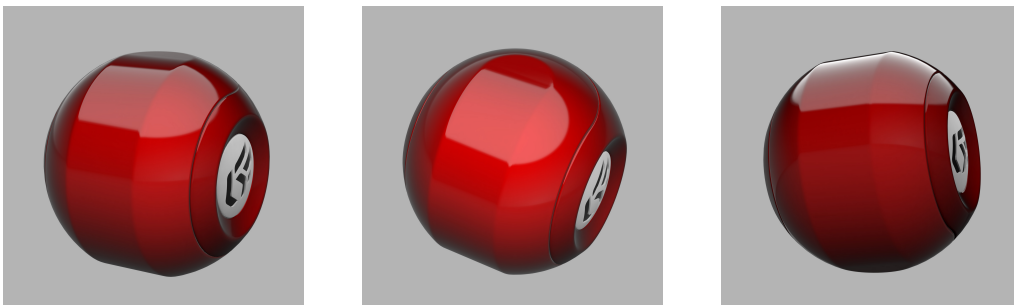

With the Fresnel Effect (refraction index = 1.518).

Preset parameters let you allocate the **refraction index** and **extinction coefficient** values corresponding to common materials such as aluminum, silver, chrome, copper, gold, etc. Custom presets can be added to this list from the **User Presets** tab in the Patchwork 3D **Settings**.

The **extinction coefficient** is a feature specific to the metals; this parameter can be left at 0 in the other cases.

The Fresnel also applies to transparent materials.

Specular Map

You can also restrict per pixel the intensity of the specular reflection of a material by using specular texture modulation (STM). This colored texture encodes the attenuation factor for each pixel the attenuation factor to be applied to the reflection (reflection = STM * specular).

A value of 255 encodes a maximum reflection and 1 encodes a virtual absence of reflection. This approach makes it possible, for example, to simply simulate embroidered fabrics. The value 255 is attributed to the pixels corresponding to the embroidery pattern, and the value 1 to the fabric.



Reflection filtering without a specular map. From left to right: diffuse layer, reflection layer without a modulation image, and result with a lightening effect.



Reflection filtering with a modulation image. From left to right: diffuse layer, reflection layer with a specular map, and result with a filtered lightening effect.

In the collapsible box, you will find **Projection** :



NOTICE

The **Resolution offset** parameter deliberately reduces the sampling level to eliminate moiré on dense patterns (houndstooth, tweed, technical weaves), at the cost of lowering the perceived detail.

The settings of the **Resolution Offset** parameter follow a procedure similar to that described for [Adjusting the Resolution offset for Diffuse \[330\]](#), with the difference that the parameter concerned is in another tab: **Diffuse** with the **Transparency** collapsible box, **Reflection** with the **Specular Map** and **Roughness** collapsible boxes, or **Bump** with the **Bump Map** collapsible box.

- The **Allow repeat on U** and **Allow repeat on V** parameters allow you to repeat the texture on U and/or V. By checking the **Mirrored** checkbox you can reflect the texture in U and/or V.

Roughness

The reflection of a frosted or brushed material is always hazy and coarse, the details disappear, and the reflection runs and spreads over the surface of the material. Only the silhouettes of the reflected objects

are still apparent. This diffusion of the reflection on the surface of the material is due to a very perturbed surface state. The **Roughness** parameter replicates this behavior.

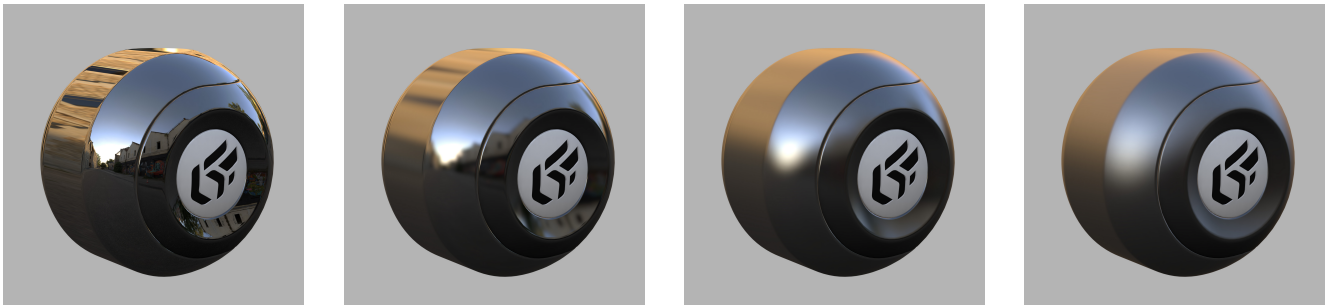

Variation of the **Roughness** of the reflection, set to values from 0 to 6.

The roughness describes the surface irregularities that cause differentiated diffusion of light. The reflected light varies randomly depending on the roughness of the surface. This change the direction of the light without affecting its intensity because it remains constant. The rougher surface have a larger and variable highlights than smooth surfaces that have concentrated specular reflections. Smooth surfaces may look brighter with the same amount of reflected light.

The **Roughness map** is a grayscale texture where the black corresponds to a roughness of 0 (smooth) and white corresponds to a roughness value of the material.

In the **Roughness map** collapsible box, check **Enable** and then click on the **None** button to load the texture that will serve for the roughness or glossiness of the material.

On the other hand, the **Gloss map** is a grayscale texture where the black corresponds to a value of the material roughness and the white corresponds to a roughness of 0 (smooth).



Gloss map example

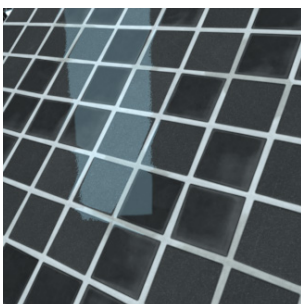

Rendering **without** a gloss map

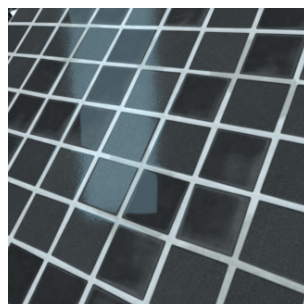

Rendering **with** a gloss map

In the collapsible box, you will find **Projection** :



NOTICE

The **Resolution offset** parameter deliberately reduces the sampling level to eliminate moiré on dense patterns (houndstooth, tweed, technical weaves), at the cost of lowering the perceived detail.

The settings of the **Resolution Offset** parameter follow a procedure similar to that described for [Adjusting the Resolution offset for Diffuse \[330\]](#), with the difference that the parameter concerned is in another tab: **Diffuse** with the **Transparency** collapsible box, **Reflection** with the **Specular Map** and **Roughness** collapsible boxes, or **Bump** with the **Bump Map** collapsible box.

- The **Allow repeat on U** and **Allow repeat on V** parameters allow you to repeat the texture on U and/or V. By checking the **Mirrored** checkbox you can reflect the texture in U and/or V.

Diffuse Filter

In the case of a standard material of the **Diffuse and Reflection** class, the additive aspect of the reflection layer tends to lighten the material when the reflection layer is superimposed.

This standard material class has a **Diffuse** filter to compensate for this lightening while conserving the original color.

A diffuse-free material (chromium, gold, steel, aluminum, etc.) is obtained by using the black filter.



Correcting lightening of a Diffuse and Reflection class standard material. From left to right: diffuse layer; diffuse layer + reflection layer without a filter (white filter); diffuse layer + reflection layer with a gray filter.

Transparent Filter

A standard material of the **Transparent Filter** class has a **Trans. Filter** setting, which plays the role of the transparent filter. This corresponds to the color of the transparent material.



Variation in the *Trans. Filter* setting of a *Transparent Filter* class standard material.

Bump

In the **Bump** tab, the parameter **Depth** adjusts the depth of the unevenness encoded in the **Bump Map**. It is a surface state roughness, i.e. not very deep. From a geometrical viewpoint, the surface is not altered and remains perfectly smooth.

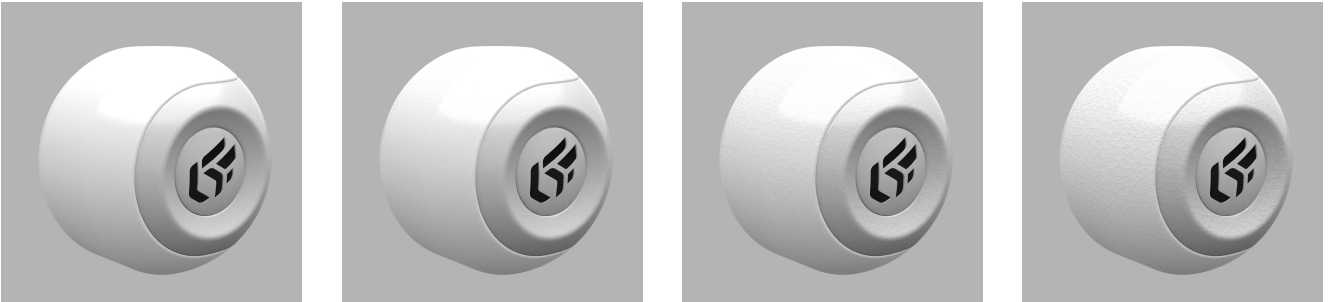

Variation in the *Diffuse Depth* setting with values from 0 to 6.

The **Reflection** parameter adjusts the depth of the hollows and bumps encoded in the **Bump Map**.

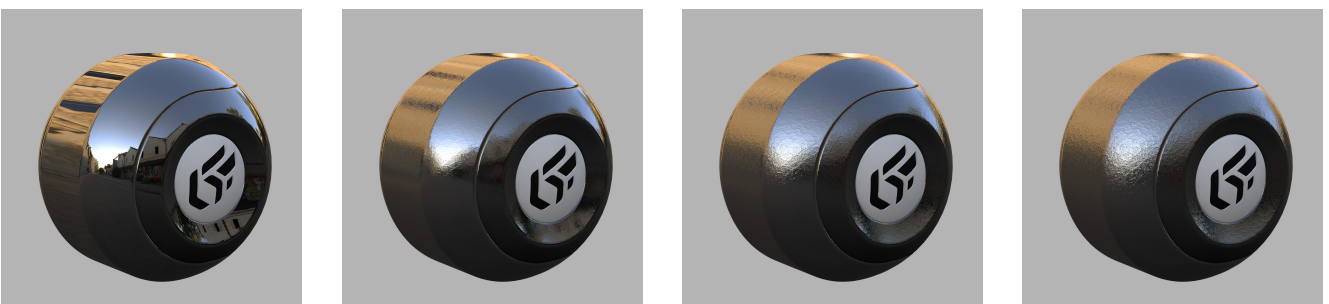

Variation in the *Reflection Depth* setting with values from 0 to 3.

Enhanced Relief

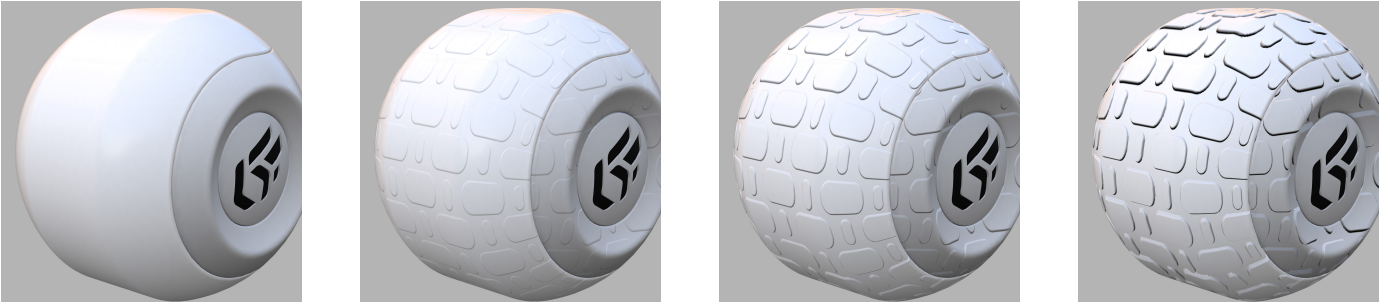

Variation in the Relief depth setting with values from 0 to 10.

Standard materials using a height map can be rendered with textural relief that is even more realistic. This option offers an enhanced perception of depth thanks to the way it handles parallax.

The use of enhanced relief is best suited to contexts where a standard material uses a texture that requires more visual depth than that which can be rendered using **diffuse depth** and **reflection depth**.

The **relief** setting provides a rendering which, while robustly real-time, requires more time to calculate. It is therefore recommended to use this option where appropriate, without overloading a scene.

Enabling Enhanced Relief



NOTE

The enhanced relief is not compatible with the use of the **diffuse depth** or the **reflection depth**. Enabling enhanced relief will disable the **diffuse depth** and the **reflection depth**, if they were previously enabled, and vice versa.



Follow these steps to enable enhanced relief for a standard material:

1. Click on the **Bump** tab from the **Materials** editor:
2. Drag and drop a texture from the texture library to the field **None** making sure it is a bump map.
3. Tick the **Parallax Bump Mapping** checkbox in the **Depth** section and provide a value for the depth.

Disabling one of these elements will also disable the enhanced relief.

Settings

The settings for enhanced relief are found in the **Bump** tab of the **Materials** editor:

Setting	Description
<p>Parallax Bump Mapping Depth</p>	<p>The depth defines the distance between the white and the black zones of the height map. The white zones are aligned on the mesh of the surface.</p> <p>Because the perceived depth of the map's black zones is set using this parameter, the height map should make use of the full range of elevation available, from white to black. When this is not possible, make sure that the map's maximum elevation will be aligned with the modeled surface, that is, that it is represented in white on the height map.</p> <p>A negative value will invert the depth of the texture: depth is rendered as rising from the surface instead of as incisions carved into the surface. While possible, this rendering is not optimal and is not recommended.</p> <div data-bbox="443 696 1453 913" style="background-color: #e0f2f1; padding: 10px; margin-top: 10px;"> <p> TIP Values between 0 and 10 are usually sufficient. Using values that are too high can create visual deformations when viewing surfaces at low angles or when viewing curved surfaces.</p> </div>
<p>Bump map</p>	<p>A height map is required. This map is a black and white texture that is assigned to the material as a bump map.</p> <p>The texture to be used as a height map can be square or rectangular. The height and the width of the texture in pixels must both be powers of two.</p> <div data-bbox="443 1128 1453 1384" style="background-color: #e0f2f1; padding: 10px; margin-top: 10px;"> <p> TIP Although Patchwork 3D will resize height maps whose dimensions are not useable, choosing textures with dimensions that are powers of two is highly recommended in order to preserve the particularities of the height map.</p> </div> <p>Enhanced relief is not compatible with bump maps used as normal maps.</p>
<p>Dimensions and Transformation of the bump map</p>	<p>These settings are modifiable as normal to adjust the dimensions, the orientation, and the position of the height map on the surface.</p>

In the collapsible box, you will find **Projection** :

**NOTICE**

The **Resolution offset** parameter deliberately reduces the sampling level to eliminate moiré on dense patterns (houndstooth, tweed, technical weaves), at the cost of lowering the perceived detail.

The settings of the **Resolution Offset** parameter follow a procedure similar to that described for [Adjusting the Resolution offset for Diffuse \[330\]](#), with the difference that the parameter concerned is in another tab: **Diffuse** with the **Transparency** collapsible box, **Reflection** with the **Specular Map** and **Roughness** collapsible boxes, or **Bump** with the **Bump Map** collapsible box.

- The **Allow repeat on U** and **Allow repeat on V** parameters allow you to repeat the texture on U and/or V. By checking the **Mirrored** checkbox you can reflect the texture in U and/or V.

Sticker

The sticker **Properties** apply when a material is used as a [sticker \[363\]](#).

You will find in the collapsible box named **Mapping** the following parameters **Allow repeat in U** and **Allow repeat in V**, which allow you to choose to repeat the texture in U and/or V.

By checking the **Mirrored** checkbox you can reflect the texture in U and/or V.

Raytracing

Each material behaves differently during a rendering by raytracing. The **Raytracing** tab gives you control over the settings for this behavior.

Environment Material

The environment material is generally applied to a hemisphere modeled about your object. The HDRI environment will be visible on this hemisphere. Your object will be integrated in this environment, the advantage of this method being that the environment changes interactively when you are zoom and pan around the scene.

After you have applied this material to your hemisphere, it is often useful to edit your environment and to change its altitude. You will thus obtain a better sense of scale and realism.

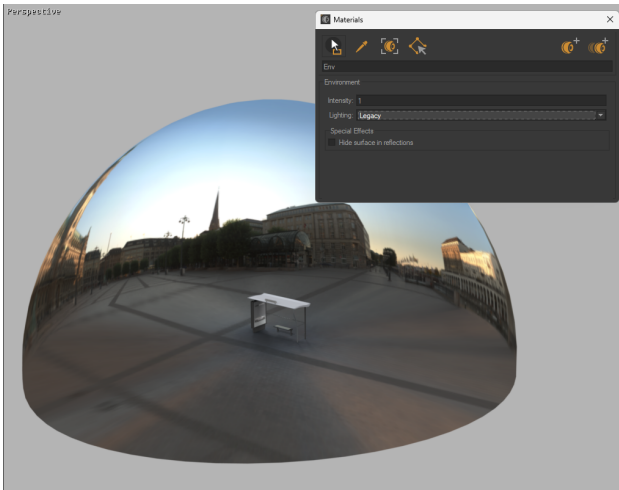

Environment material lighting behavior

Available in: **Matter** > **Libraries**  > **Material Library** 

Principle

This feature is designed to provide users with more control over how scenes are illuminated, thereby balancing compatibility, visual fidelity, and real-time performance.

A decision table has been created to help you quickly compare and select the lighting mode that best fits your needs.

When to use it?

- When you hesitate between the following modes **Legacy**, **Environment**, **Lightmaps**, or **Environment and lightmaps**.
- When you need to preserve an existing rendering or isolate/combine lighting sources.

Details of lighting modes:

Mode	Goal	Lighting	Behaviour	Example
Legacy	Maintain the original rendering of old scenes.	Uses environment lighting when no lightmaps are present. Uses lightmaps if they exist.	Lighting identical to that of the version used to create the database.	Recover the lighting behavior of a scene created in a version before Patchwork 3D 2025.

Mode	Goal	Lighting	Behaviour	Example
Environment	Control lighting via an HDRI environment only.	The Environment material lights the scene with its values	Lightmaps are ignored, even if present.	Illuminate the scene only through the HDRI environment.
Lightmaps	Isolate baked lightmaps.	Only the lightmaps of the 3D model illuminate the scene	The light emission from the HDRI environment material is ignored.	Illuminate an interior scene in which detailed shadows are baked with lightmaps. Additional HDRI environment lighting would create inconsistencies.
Environment and lightmaps	Combine the HDRI environment lighting with lightmaps.	HDRI environment + Lightmaps	Both the HDRI environment material and the lightmaps light up the scene.	Illuminate a scene where a vehicle's headlights enhance the setting, along with the ambient light from the HDRI environment.

Apply a lighting mode to the scene

1. In the right sidebar of the Patchwork 3D interface, display the tab **Material Library**  and double-click on an Environment material in the materials list.
2. In the **Materials** window that appears, select the desired lighting mode between **Legacy**, **Environment**, **Lightmaps**, or **Environment and lightmaps** in the **Lighting** dropdown menu.

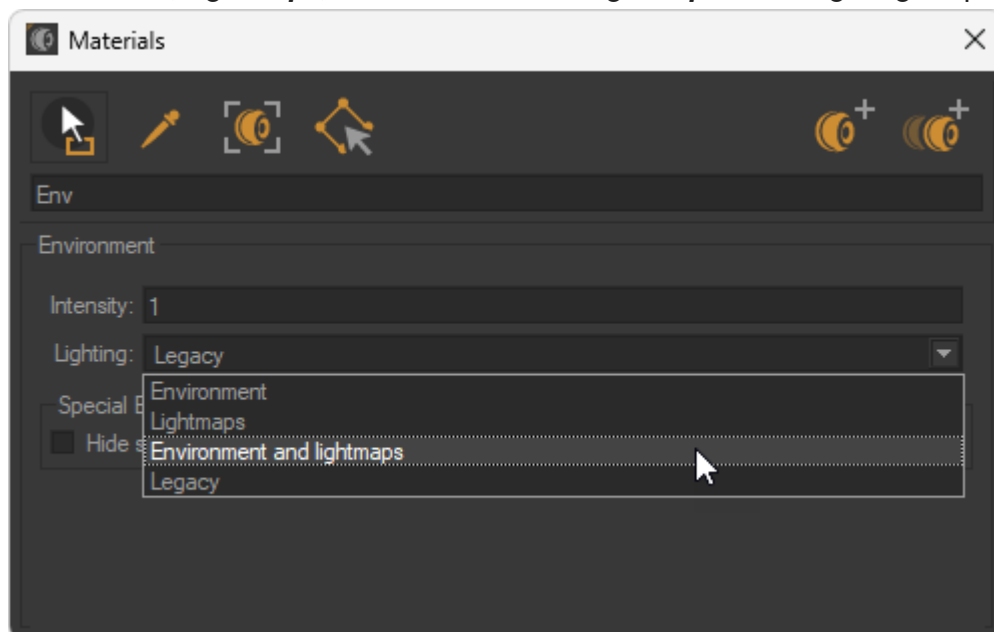

3. Check the lighting rendering.

Media

In the video below, visualize the different lighting behaviors depending on the mode selected.

<https://www.youtube.com/embed/4rquCUcm5Wg>

Using an Alternate Background Texture as an Environment Material

In order to reduce the resources used by the graphics card as well as the size of .kdr files, a high-dynamic range, average resolution (typically 1024×512 pixels) environment may be coupled with a low-dynamic range, high-resolution (4096×2048 pixels) texture instead of using a high-dynamic range, high-resolution environment.

This modification applies to an environmental material. The most common use of this material is to create in **Shaper** a **Hemisphere** primitive enveloping the whole scene (typically with a diameter of 5 to 10 meters), and applying the environment material on it in **Matter**.

To couple a high-dynamic range, average-resolution environment to a low-dynamic range, high-resolution texture, the following steps must be performed:

1. In **Matter**, import an HDR or EXR file of reasonable resolution (1024×512 or 2048×1024) and apply it to the product.
2. Open the **Environment Properties Editor** for this environment. The **Background** box indicates that no alternate background texture has been defined.
3. Select a texture with a higher resolution in a low dynamic range format (JPG, PNG...) and couple it with the active environment by drag-and-drop onto the **None** button in the **Alternative Background Map** box. The texture is automatically applied to the environment material. The filename replaces the mention **None**.



TIP

The environment and the texture chosen must be in the same format, which means they must use the same projection (**Longitude-Latitude**, **Angular** or **Vertical cross**). In general, the most appropriate texture is a version of the environment on which a tone mapping is applied and used as an omnidirectional plate.

The **Alternative Background Map** has the following functions:

- The button  is for deleting the active alternative background texture.
- Clicking on the button tagged **None** or the name of the file defined as an alternative background texture opens the Matter sidebar's texture library and selects the texture associated with the background chosen.

Matte Material

The matte material in Matter makes it possible to view only the shadow of an object. It is generally applied to a plane placed under your object. It will allow you to compose your 3D object on a 2D background; it will help to "set" this object in the scene.



Mirror Material

The mirror material is necessarily applied to a plane. It will allow you to simulate a mirror or a pane of glass in which the other surfaces in the scene will be reflected.

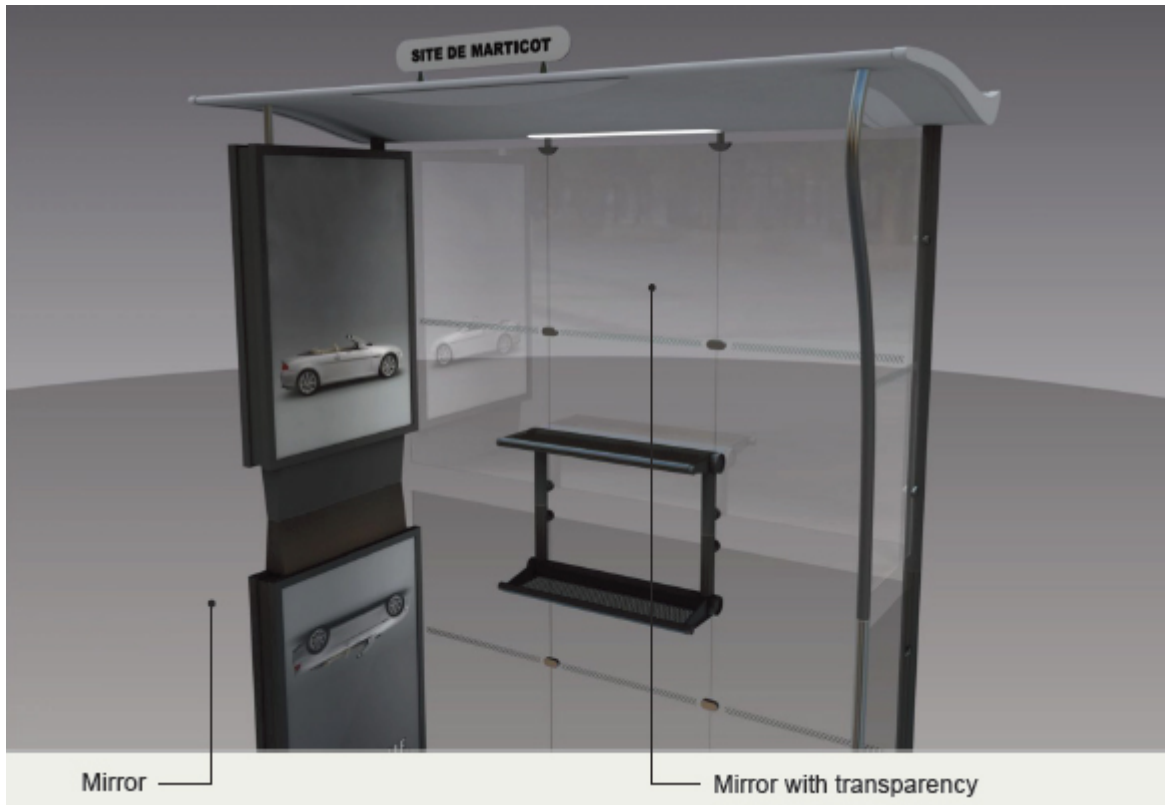

In these sections, you will learn how to create a mirror material using the **Diffuse**, **Reflection**, and **Bump** tabs.

Diffuse

Diffuse Color

The color **Filter** setting corresponds to the color perceived when the material is lit by white light. As the material reacts like a filter, it reflects part of the light it receives. The perceived color of an object is thus greatly influenced by the lighting environment. If we consider that white light is made up in equal parts of green, red and blue (empirical computer model), then a black body absorbs all these components, a white body reflects them without alteration, a red body absorbs the green and blue, etc.

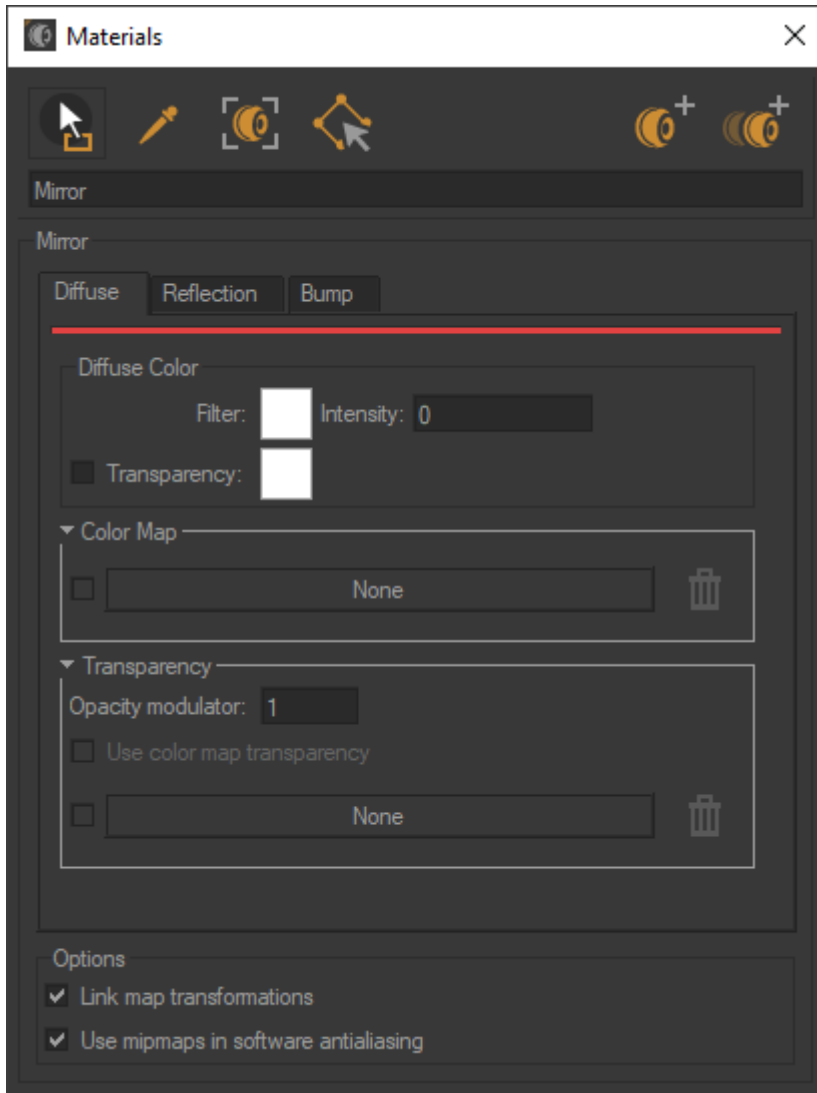

The parameter **Intensity** allows you to amplify or attenuate by a multiplicative factor the effect of the light environment on the material.

Color Map

Some materials have a pattern or motif that is created by repeating or not an image across the surfaces to which the material is assigned. The **Color Map** settings are used to assign, resize, and position the first instance of such an image.

Color maps are image or video textures. To use a texture as a color map, drag it from the sidebar texture library and drop it in the **color map** zone. To be shown, the color map must also be enabled by ticking the checkbox next to the color map zone.

The texture dimensions are used by default for an image texture.

For a video texture, the longest edge of the format is scaled to one meter by default. The format's aspect ratio is respected. Any texture used as a color map will repeat.

You will find in the collapsible box named **Mapping** the following parameters **Allow repeat in U** and **Allow repeat in V**, which allow you to choose to repeat the texture in U and/or V. By checking the **Mirrored** checkbox, you can reflect the texture in U and/or V.

Reducing moiré on high-frequency textures

Available in: **Matter** > **Material Library**  > material > **Diffuse** > **Color Map** > **Resolution offset**

Principle

The **Resolution offset** parameter deliberately reduces the sampling level to eliminate moiré on dense patterns (houndstooth, tweed, technical weaves), at the cost of lowering the perceived detail.

The setting can vary from -15 to 15 to control the level of detail of the textures shown.

- Negative values (e.g., of **-1** to **-15**): These values simulate a closer camera. This allows the texture to be displayed in greater detail, making it sharper than it would be by default.
- Value **0**: The default, which displays the texture in its normal level of detail, based on the distance from the camera.
- Positive values (e.g., of **1** to **15**): These values simulate the distance between the camera and the textured surface. This has the effect of making the texture more blurry, as if seen from a distance

In summary, the **Resolution offset** adjusts the sharpness of textures to make them more detailed or blurry, simulating a change in camera distance.



NOTE

It is important to note that this setting does not change the original texture's resolution; rather, it adjusts the level of detail displayed. Negative values can improve perceived sharpness, while positive values can improve performance by reducing detail

When to use it?

To be used for:

Symptom	Action on Resolution offset	Expected behaviour
Visible moiré	Increase the value slightly.	Stable pattern, attenuated interference.
Texture perceived as too soft after adjustment.	Reduce the value and reevaluate at several distances.	Stability/sharpness compromise restored.
Persistent artifacts with sharp angles.	Refine the value and check the result.	Additional reduction in directional flicker.

Adjusting the Resolution offset for Diffuse

1. Starting from the **Material Library** , double-click on the material that needs adjustment to reduce the moiré effect. The **Materials** editor opens.
2. In the **Diffuse** tab, locate the **Color Map** collapsible box and click on the **None** button to open the

Texture Library .

3. Starting from the **Texture Library** , drag and drop the desired texture onto the **None** button.
4. Collapsible boxes **Color Map**, and **Mapping** unfold. In the latter, select the desired value for the **Resolution offset** parameter.
5. Increase the **Resolution offset** gradually until the pattern is stabilized, without superfluous blur.
6. Validate on several angles and distances to highlight a possible Moiré (before and after comparison if necessary).

Media

Use case for reducing the moiré effect on the upholstery of the seat of a chair using the Resolution Offset parameter.

<https://www.youtube.com/embed/G66wFe7kMcY>

Transparency of the Diffuse Layer

The **Transparency** of the mirror manages the transparency rate depending on the color depth from colored to black (non transparency) and its refraction color.

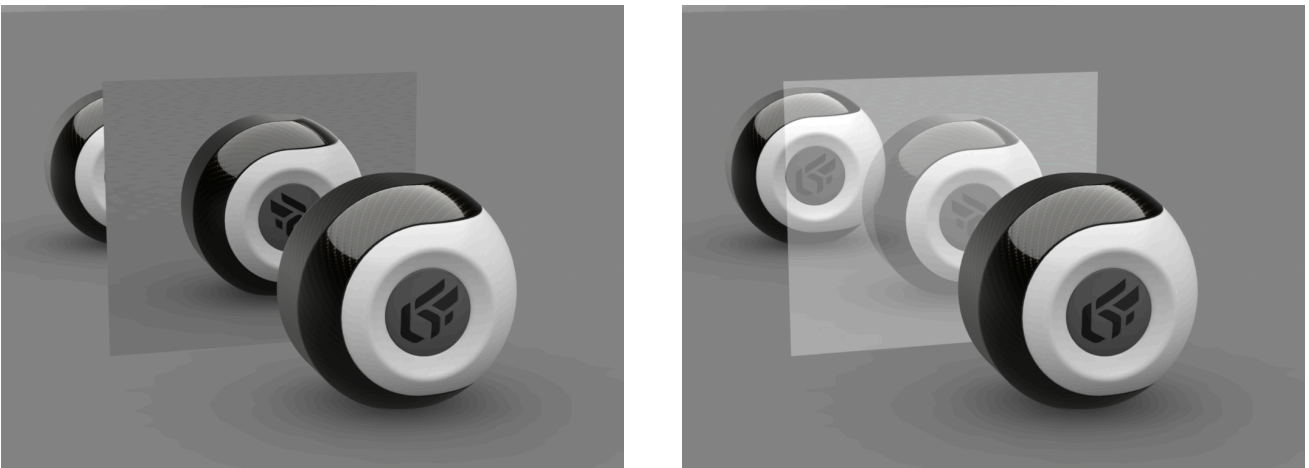

On the left, Mirror material without transparency color. On the right, Mirror material with transparency color. Selected transparency color: white #FFFFFF

The **Transparency** collapsible box lets you use a texture to control the transparency of the material. The alpha layer contained in the images (PNG format) is used to define the transparency of the texture.

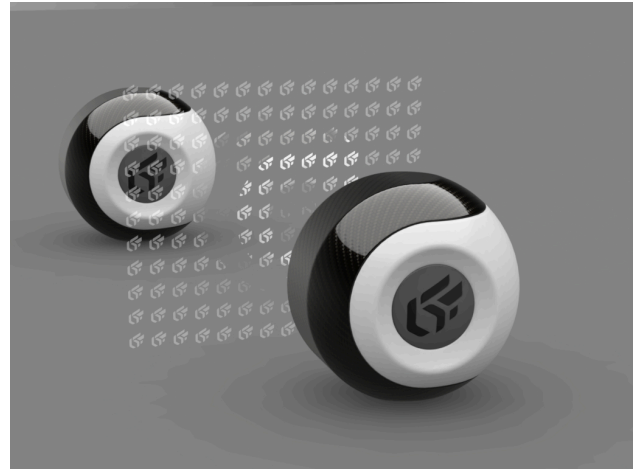
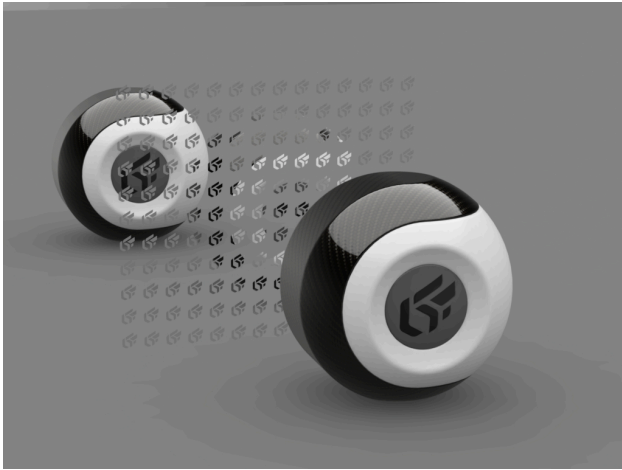

On the left, Mirror material with transparency texture. On the right, Mirror material with texture and transparency color (white #FFFFFF) Selected transparency color: white #FFFFFF

If the texture used as image alpha does not have an alpha channel (JPG image), it is the alpha or the luminosity of the image color map that is used as the alpha channel. In this case, check **Use color map transparency**. The darkest colors correspond to the most transparent areas:

You will find in the collapsible box named **Mapping** the following parameters **Allow repeat in U** and **Allow repeat in V**, which allow you to choose to repeat the texture in U and/or V.

By checking the **Mirrored** checkbox you can reflect the texture in U and/or V.

Reflection

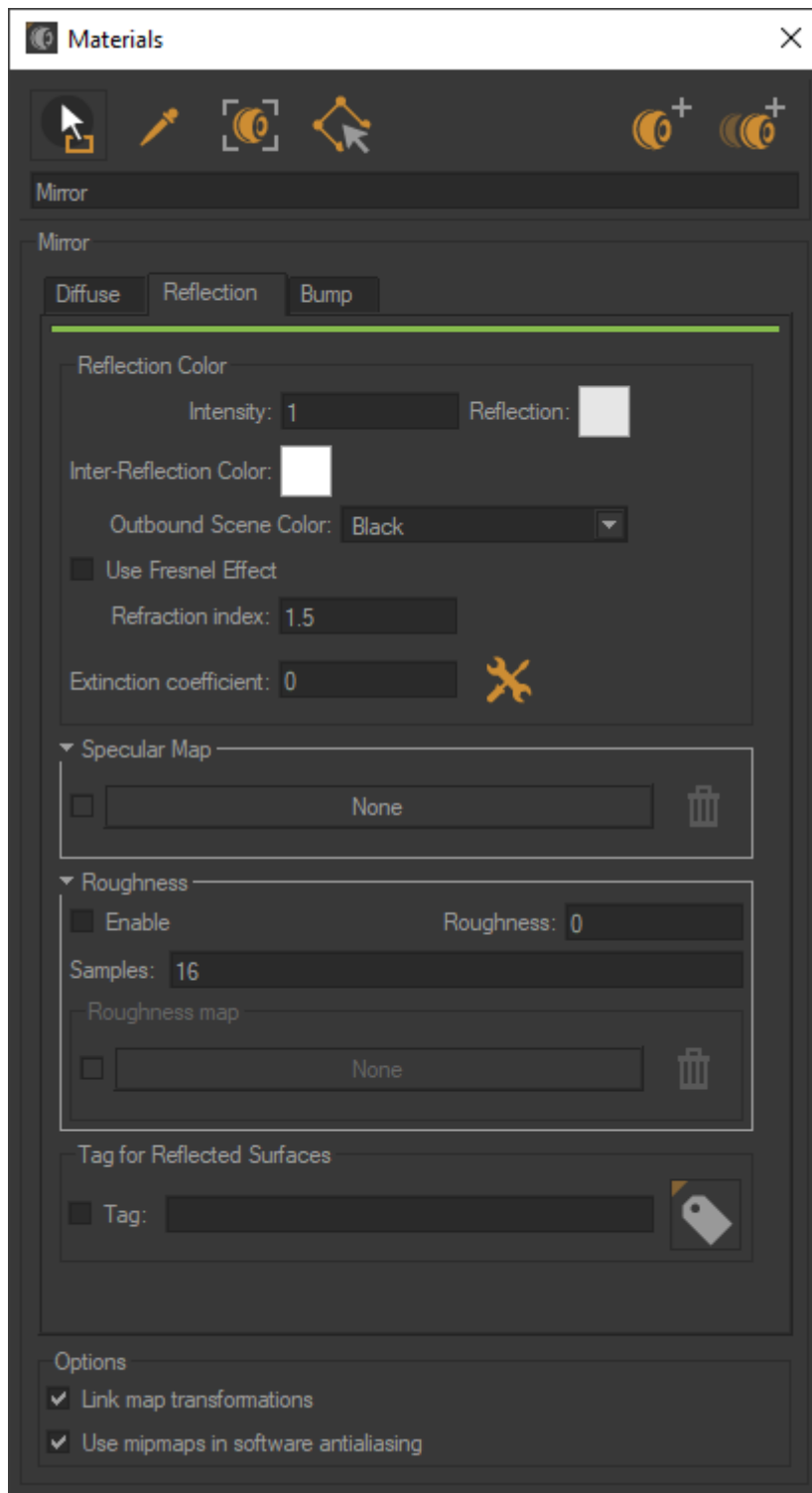

You can filter the surfaces that will be reflected using the **Tag for Reflected Surfaces** option. This option uses the tags assigned to surfaces in **Shaper** to limit the surfaces that are reflected. In a complex scene, this can significantly improve rendering time.

For more information on tags, see [Tag Manager \[186\]](#).

Reflection color

To set mirror reflection properties, use the following options:

- The **Reflection** of the mirror manages the reflection rate according to the color depth, from light to black (no reflection), and the color saturation, from white to saturated color (colored reflection). The **Intensity** parameter allows you to adjust the reflection intensity emitted by the material. The **Intensity** value varies in principle between 0 and 1, but a higher value makes it possible to counterbalance a rather dull lighting environment.
- The **Inter-reflection color** gives color to a mirror when viewed through another mirror.
- The **Outbound Scene Color** allows you to choose the reflection color of the scene between black, background, or environment. More precisely, this determines what happens when the reflection from the mirror does not encounter any surface.

The Fresnel is an optical effect. The greater the oblique angle at which a glossy surface is observed, the less visible will be the color of the surface, which forms a white reflection.

In the case of a glossy transparent material, the Fresnel will make the surface increasingly opaque the more the viewing angle is reduced.



NOTE

Preset parameters let you allocate the **refraction index** and **extinction coefficient** values corresponding to common materials such as aluminum, silver, chrome, copper, gold, etc. Custom presets can be added to this list from the **User Presets** tab in the Patchwork 3D **Settings**.

The **extinction coefficient** is a feature specific to the metals; this parameter can be left at 0 in the other cases.

Specular Map

You can also restrict per pixel the intensity of the specular reflection of a material by using specular texture modulation (STM). This colored texture encodes the attenuation factor for each pixel the attenuation factor to be applied to the reflection (reflection = STM * specular).

A value of 255 encodes a maximum reflection and 1 encodes a virtual absence of reflection. This approach makes it possible, for example, to simply simulate embroidered fabrics. The value 255 is attributed to the pixels corresponding to the embroidery pattern, and the value 1 to the fabric.

In the collapsible box, you will find **Projection** :



NOTICE

The **Resolution offset** parameter deliberately reduces the sampling level to eliminate moiré on dense patterns (houndstooth, tweed, technical weaves), at the cost of lowering the perceived detail.

The settings of the **Resolution Offset** parameter follow a procedure similar to that described for [Adjusting the Resolution offset for Diffuse \[330\]](#), with the difference that the parameter concerned is in another tab: **Diffuse** with the **Transparency** collapsible box, **Reflection** with the **Specular Map** and **Roughness** collapsible boxes, or **Bump** with the **Bump Map** collapsible box.

- The **Allow repeat on U** and **Allow repeat on V** parameters allow you to repeat the texture on U and/or V. By checking the **Mirrored** checkbox you can reflect the texture in U and/or V.

Roughness

The reflection of a frosted or brushed material is always hazy and coarse, the details disappear, and the reflection runs and spreads over the surface of the material. Only the silhouettes of the reflected objects are still apparent. This diffusion of the reflection on the surface of the material is due to a very perturbed surface state. The **Roughness** parameter replicates this behavior.

The roughness describes the surface irregularities that cause differentiated diffusion of light. The reflected light varies randomly depending on the roughness of the surface. This change the direction of the light without affecting its intensity because it remains constant. The rougher surface have a larger and variable highlights than smooth surfaces that have concentrated specular reflections. Smooth surfaces may look brighter with the same amount of reflected light.

The **Samples** parameter reduces noise, but it also affects rendering speed. By increasing the number of samples, the noise decreases and the rendering quality becomes sharper and more precise, but it takes more time.

The **Roughness map** is a grayscale texture where the black corresponds to a roughness of 0 (smooth) and white corresponds to a roughness value of the material.

In the **Roughness map** collapsible box, check **Enable** and then click on the **None** button to load the texture that will serve for the roughness or glossiness of the material.

On the other hand, the **Gloss map** is a grayscale texture where the black corresponds to a value of the material roughness and the white corresponds to a roughness of 0 (smooth).

In the collapsible box, you will find **Projection** :



NOTICE

The **Resolution offset** parameter deliberately reduces the sampling level to eliminate moiré on dense patterns (houndstooth, tweed, technical weaves), at the cost of lowering the perceived detail.

The settings of the **Resolution Offset** parameter follow a procedure similar to that described for [Adjusting the Resolution offset for Diffuse \[330\]](#), with the difference that the parameter concerned is in another tab: **Diffuse** with the **Transparency** collapsible box, **Reflection** with the **Specular Map** and **Roughness** collapsible boxes, or **Bump** with the **Bump Map** collapsible box.

- The **Allow repeat on U** and **Allow repeat on V** parameters allow you to repeat the texture on U and/or V. By checking the **Mirrored** checkbox you can reflect the texture in U and/or V.

Media

Example of a scene using the Roughness map in the Mirror material.

<https://www.youtube.com/embed/cXyYpUCI-b4>

Bump

In the **Bump** tab, the parameter **Depth** adjusts the depth of the unevenness encoded in the **Bump Map**. It is a surface state roughness, i.e. not very deep. From a geometrical viewpoint, the surface is not altered and remains perfectly smooth.

The **Reflection** parameter adjusts the depth of the hollows and bumps encoded in the **Bump Map**.

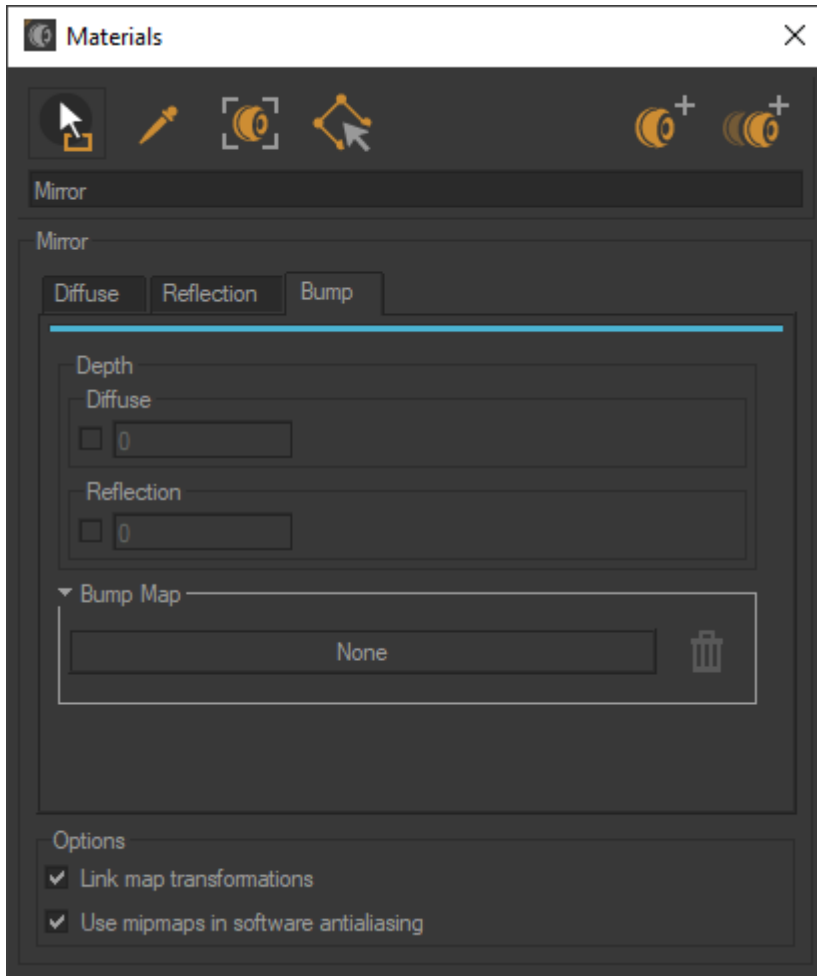

In the **Bump Map** collapsible box, click the **None** button to load the texture, which will serve as a reference for the bump or the glossiness of the material.

In the collapsible box, you will find **Projection** :



NOTICE

The **Resolution offset** parameter deliberately reduces the sampling level to eliminate moiré on dense patterns (houndstooth, tweed, technical weaves), at the cost of lowering the perceived detail.

The settings of the **Resolution Offset** parameter follow a procedure similar to that described for [Adjusting the Resolution offset for Diffuse \[330\]](#), with the difference that the parameter concerned is in another tab: **Diffuse** with the **Transparency** collapsible box, **Reflection** with the **Specular Map** and **Roughness** collapsible boxes, or **Bump** with the **Bump Map** collapsible box.

- The **Allow repeat on U** and **Allow repeat on V** parameters allow you to repeat the texture on U and/or V. By checking the **Mirrored** checkbox you can reflect the texture in U and/or V.

Multilayer Materials

Multilayer materials allow you to combine effects which previously required the use of stickers. Thus you can easily create metallic and pearlescent paints, carbon fiber, varnished wood, perforated leather, etc., which can be assigned directly as a single material.

The technique to assign a multilayer material on a surface is identical to that of a single material.

Layers are created one after another in the upper part of the **Materials** editor.

When a layer is created, using the **New Layer** button, you have the choice of three different types: **diffuse layer**, **specular layer**, **illumination layer**, **flakes layer**.

The order of the layers is important: if a completely opaque layer is on top, it will mask all layers beneath it. You can move a layer in the list by clicking and dragging.

Each type of layer is represented by a different icon: a top-lit ball for a diffuse layer, a luminous ball for an illumination layer, and a mirror-finish ball for a reflective layer.

Types of Layers: Diffuse Layer

In general, this is the first layer created, the one giving the basic color. For a standard material, the parameters are given under the **diffuse** tab. The same semi-transparency options as those for the standard materials apply.

In fact, there are only two differences: the illumination parameter has disappeared (an illumination layer must now be created) and the diffuse grain is incorporated directly.

The diffuse layer parameters operate in the same way as those of the **diffuse** tab for the standard material.

Mixing the diffuse layer is standard: if the diffuse layer uses a see-through image, the layer underneath is shown in proportion through it.

Diffuse layers can accept a video texture as a **Color Map**.

In the collapsible box, you will find **Projection** :



NOTICE

The **Resolution offset** parameter deliberately reduces the sampling level to eliminate moiré on dense patterns (houndstooth, tweed, technical weaves), at the cost of lowering the perceived detail.

The setting of the **Resolution offset** follows a procedure similar to that described for [Adjusting the Resolution offset for Diffuse \[330\]](#), except that the parameter in question is in another layer: **Diffuse** with the **Color Map**, **Bump**, and **Transparency** collapsible boxes, or **Specular** with the **Specular Map**, **Roughness**, and **Bump** collapsible boxes.

- The **Allow repeat on U** and **Allow repeat on V** parameters allow you to repeat the texture on U and/or V. By checking the **Mirrored** checkbox you can reflect the texture in U and/or V.

Types of Layers: Specular Layer

In the same way that a diffuse layer incorporates its own diffuse grain, a specular layer incorporates its own specular grain. This approach provides better hierarchy of the layer parameters and provides more options. The specular layer is parameterized in the same way as the parameters under the **reflection** tab for the standard material.

A specular layer operates in additive mode: the reflection is added to the combination of lower layers, but provides overall filtering of the lower layers and variable attenuation according to the Fresnel reflection. If the **Transmission attenuation** option is ticked, then some of the reflected light on the surface is not transmitted to the lower layers, making the light behave realistically.

You will find in the **Roughness** collapsible box, the **Roughness map** parameter, and the **Gloss map** only after enabling the roughness and then dragging and dropping a texture from the texture library on the **None** field.

- The **Roughness map** is a grayscale texture where the black corresponds to a roughness of 0 (smooth) and white corresponds to a roughness value of the material.
- On the other hand, the **Gloss map** is a grayscale texture where the black corresponds to a value of the material roughness and the white corresponds to a roughness of 0 (smooth).

In the collapsible box, you will find **Projection** :



NOTICE

The **Resolution offset** parameter deliberately reduces the sampling level to eliminate moiré on dense patterns (houndstooth, tweed, technical weaves), at the cost of lowering the perceived detail.

The setting of the **Resolution offset** follows a procedure similar to that described for **Adjusting the Resolution offset for Diffuse [330]**, except that the parameter in question is in another layer: **Diffuse** with the **Color Map**, **Bump**, and **Transparency** collapsible boxes, or **Specular** with the **Specular Map**, **Roughness**, and **Bump** collapsible boxes.

- The **Allow repeat on U** and **Allow repeat on V** parameters allow you to repeat the texture on U and/or V. By checking the **Mirrored** checkbox you can reflect the texture in U and/or V.

Types of Layers: Illumination Layer

The **illumination color** is found in the standard material under the **diffuse** tab and allows a certain luminosity to be generally added to the material. The brightness may be greater than 1.

The **velvet effect** in the standard material is found under the **reflection** tab, but also acts as a light addition, this time depending on the viewing angle on the surface. The added luminosity is given by a gradient ramp multiplied by a specifiable factor, which may be greater than 1.

If a modulation image is activated, it filters the modulation color on the surface. If the velvet effect is used, ticking the **Use modulation image** box modulates the effect so as to provide a more realistic appearance.

Note that an illumination layer includes a grain, which affects only the velvet effect if activated. The grain reinforces the realism, especially of fabrics.

An illumination layer operates in additive mode: its contribution is added to the lower layers.



TIP

Most standard materials may be recreated in the form of multilayer materials with a single diffuse layer and a single specular layer.

For more complex materials, nothing prevents you from using several layers of the same type. For example, a 3D open mesh fabric may use one diffuse layer for the lower textile and another diffuse layer, made visible using the transparency effect, for the top layer. If the underside is glossy, then the latter diffuse layer will be on the specular layer of the lower layer. The organization of the material would thus be:

- Specular layer, upper textile
- Diffuse layer, upper textile
- Specular layer, lower textile
- Diffuse layer, lower textile

If you also want to use the velvet effect because the surface of the fabric is partly soft or textured, inserting an illumination at the right place will do the job:

- Specular layer, upper textile
- Illumination layer, upper textile
- Diffuse layer, upper textile
- Specular layer, lower textile
- Diffuse layer, lower textile



NOTE

The number of layers that can be used is limited only by the capacity of your graphics card. If you want to go further, the system will still operate but at a cost of slowing down the display.

Flakes layer

The flakes layer is particularly useful when you want to reproduce, for example, the effect of glittering paint of car paint type like on a car body.

The car paint type material is a multilayer material (diffuse, specular and flakes). The flakes layer is generated using the Flakes Layer Editor. To add a flakes layer, click **Add Flakes Layer**.

All flakes can have the same color, or follow a distribution given by a color palette available in the [Flakes](#)

[Color Editor \[452\]](#) . See the **Multiple Colors** parameter. Random variations of the same color are possible between the flakes via the **L +/-** (Luminance) or **a +/-** or **b +/-** (chrominance) parameters which define a standard deviation according to the Normal distribution.

Flakes can also vary in size thanks to the **Size** parameter. The **Orientation** is expressed in degree with variations via the standard deviation +/- of the Normal distribution.

The visibility of the flakes can be dimmed according to their angle which is defined by the combination of a depth value and the texture of the Normal distribution.

The **Sides** parameter defines the number of sides of a flake (from 3 to 8 sides): eg. triangle, square, octagon.

The **Texture Size** parameter sets the size of the texture in pixels.

- The higher the texture size, the better the definition with longer generation time and more data to store.
- The smaller the texture size, the less good is the definition with a short build time and less data to store. The greater the probability of seeing pattern repetitions of textures.

The **Seed** parameter is used to generate a different texture from the same parameters. To avoid the redundancy of a texture the **Seed** parameter randomly generates a new texture according to a value.

You have the option to generate a texture with glitter randomly distributed on the texture **Flakes Distribution > Random** or evenly distributed **Flakes Distribution > Even**. Choose the flakes distribution according to the result you want. For a more realistic rendering of the generated texture, the random distribution of flakes is recommended for a texture composed of a lot of flakes.

If you enable the **Automatically update textures** parameter, after each change to the flake texture settings, the layer will automatically update. If instead the box has not been checked, which is the case by

default, it is necessary to click on this icon  after each modification of the texture parameters.

The features available in the **Reflexion Color [333]**, **Fresnel [334]**, and **Roughness [335]** collapsible boxes are described in their dedicated section.

In the collapsible box, you will find **Projection** :



NOTICE

The **Resolution offset** parameter deliberately reduces the sampling level to eliminate moiré on dense patterns (houndstooth, tweed, technical weaves), at the cost of lowering the perceived detail.

The settings of the **Resolution Offset** parameter follow a procedure similar to that described for **Adjusting the Resolution offset for Diffuse [330]**, with the difference that the parameter concerned is in another tab: **Diffuse** with the **Transparency** collapsible box, **Reflection** with the **Specular Map** and **Roughness** collapsible boxes, or **Bump** with the **Bump Map** collapsible box.

- The **Allow repeat on U** and **Allow repeat on V** parameters allow you to repeat the texture on U and/or V. By checking the **Mirrored** checkbox you can reflect the texture in U and/or V.

The features in the **Advanced** collapsible box are explained in the **specular layer [357]** section above in this chapter.

Enhanced Relief

Multilayer materials using a height map can be rendered with textural relief that is even more realistic. This option offers an enhanced perception of depth thanks to the way it handles parallax.

The use of enhanced relief is best suited to contexts where a standard material uses a texture that requires more visual depth than that which can be rendered using bump maps in diffuse and specular layers.

The **Parallax Bump Mapping** tab gives access to settings that provide a rendering which, while robustly real-time, requires more time to calculate. It is therefore recommended to use this option where appropriate, without overloading a scene.

Enabling Enhanced Relief



NOTE

Enhanced relief is not compatible with the use of bumpmaps to create the impression of relief. Enabling enhanced relief for a layer will disable the bump for that layer, if it was enabled, and vice-versa.

Enhanced relief must be enabled:

- globally for the material in the **Parallax Bump Mapping** tab,
- then for the required layers in the **Layers** tab. By default, it is disabled in all layers.



Enable enhanced relief in the **Parallax Bump Mapping** tab of the **Materials** editor for a standard material:

1. Drag and drop a texture from the texture library to the field **None** making sure it is a bump map. Switch to the **Layers** tab:
2. For the layer or layers that should use enhanced relief, tick the **Use Parallax Bump Mapping** checkbox in the **Bump** zone.

Disabling one of these elements will also disable the enhanced relief.

Settings

The settings for enhanced relief are found in the **Parallax Bump Mapping** tab of the **Materials** editor:

Setting	Description
<p>Depth</p>	<p>The depth defines the distance between the white and the black zones of the height map. The white zones are aligned on the mesh of the surface.</p> <p>Because the perceived depth of the map's black zones is set using this parameter, the height map should make use of the full range of elevation available, from white to black. When this is not possible, make sure that the map's maximum elevation will be aligned with the modeled surface, that is, that it is represented in white on the height map.</p> <p>A negative value will invert the depth of the texture: depth is rendered as rising from the surface instead of as incisions carved into the surface. While possible, this rendering is not optimal and is not recommended.</p> <div data-bbox="437 696 1453 913" style="background-color: #e0f2f1; padding: 10px;"> <p> TIP Values between 0 and 10 are usually sufficient. Using values that are too high can create visual deformations when viewing surfaces at low angles or when viewing curved surfaces.</p> </div>
<p>Height Map</p>	<p>A height map is required. This map is a black and white texture that is assigned to the material as a Bump map.</p> <p>The texture to be used as a height map can be square or rectangular. The height and the width of the texture in pixels must both be powers of two.</p> <div data-bbox="437 1128 1453 1384" style="background-color: #e0f2f1; padding: 10px;"> <p> TIP Although Patchwork 3D will resize height maps whose dimensions are not useable, choosing textures with dimensions that are powers of two is highly recommended in order to preserve the particularities of the height map.</p> </div>
<p>Dimensions and Transformation of the bump map</p>	<p>These settings are modifiable as normal to adjust the dimensions, the orientation, and the position of the height map on the surface.</p>

Seam Material

The **Seam** material simulates lines of stitching. The **Seam** material is transparent, except where the threads are visible. This material is generally applied to a thin, straight surface that has been superimposed over the main surface.

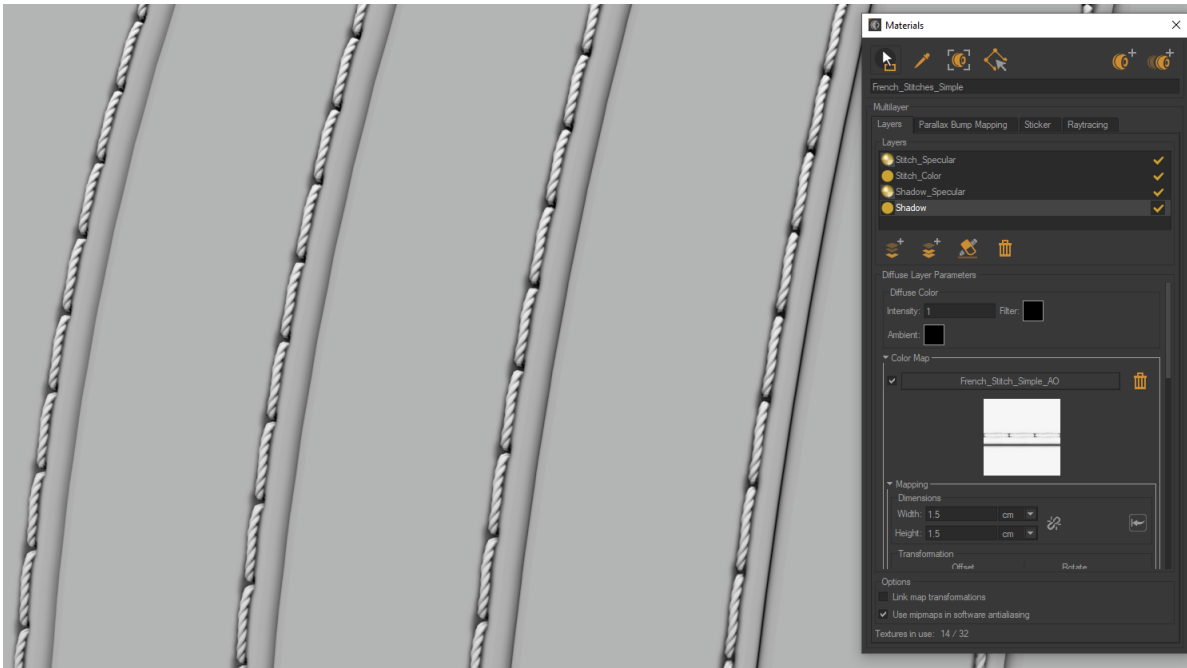

Lines of stitching created with a seam material.

The structure of this material is similar to that of the standard material. It is composed of two layers, a diffuse layer and a reflection layer, and it has texture properties.

Diffuse

The diffuse parts of the seam material represent the thread.

The **Diffuse Color**, which is principally given by the **Filter** color, is the thread color.

The **Color Map** gives the pattern of stitches. It is generally the same as the image used for the **Seam Map** in the **Bump** tab.

Reflection

Based on the type of thread used, the stitches can appear more or less shiny. As for a standard material, the **Reflection Color** as an additive value, the **roughness**, and the **diffuse filter** can be adjusted.

Bump

The realism of the stitching's appearance is due, in part, to the bump texture.

The texture of this type of material is assembled from two different image maps: a **Pleat Map** and a **Seam Map**.

The **Seam map** gives the pattern for the individual stitches. Without this map, the material would be entirely transparent. The color of the diffuse filter will fill in the lighter areas of this image. The zones with an alpha background will remain transparent, showing the material assigned to the surface below the seam surface.



Example of a seam map. The checkered zones represent an alpha background.

If the material is gathered or pleated under the stitching, use the **Pleat map** settings to impose the texture.

Sticker Material

A sticker is a material pattern that can be applied to a surface and oriented, similarly to a physical sticker.

The surfaces of **Matter** may receive an unlimited number of stickers. These stickers are used to position product graphical elements such as a logo, documentation, a mark, iconography, and so on, interactively on model surfaces.

Any standard, multilayer, seam or environment material can be applied in sticker mode. In fact, the sticker material is a standard material for which the sticker mode (**Always use as a sticker**) is imposed by default. In this mode, the textures defining the material are no longer repeated on the surface. The stickers are overlaid in successive coats according to their order of creation on the surface. This order can, however, be modified later in the **Surface Properties Editor**.



Successive layers of stickers.

Furthermore, if the alpha coat of the diffuse texture is present, it defines the transparency zones of the sticker. A value of zero in the alpha coat encodes a transparent pixel.



Left: with alpha zones. Right: without alpha zones (RGB only).

Managing Applied Stickers

You have access to the list of stickers of a surface, of which you can modify the order, the transformation, and the name.

This function is available via the contextual menu of the selected surface. Right-click on the surface then select surface, **Edit the properties**, and then select the **sticker** tag.



TIP

To click on a surface, the surface must be visible. Display all surfaces by right-clicking within the viewport and choosing the option, **Show All (Ctrl+Shift+R)**

The sticker placed at the top of the list in the **Stickers manager** is the one perceived in the foreground in the active view.



The up and down arrows allow you to change the layer order of the stickers. Select the sticker and click on the arrows according to the desired arrangement.

You have the possibility of renaming the stickers by entering a new name in the input field located at the bottom of the **Stickers** zone.

The U and V **Offset** and the **Rotation** parameters of the **Transformation** zone allow the sticker to be placed more precisely by entering numerical values directly or by using the keyboard cursor arrows.

Assigning a Material to a Surface

To assign a material to a surface, you can:

- Drag and drop from the editor **Materials**,
- Drag and drop from active element in the **Matter** sidebar's material library,
- Drag and drop from a selected element in the **Matter** sidebar's material library.

The use of the key modifies, **Ctrl**, **Alt**, and **Shift**, can optimize the assignment of materials to one or several surfaces of the active model.



From right to left: Starting scene; CTRL = replace on all surfaces with the same material; MAJ = apply as sticker.

Ctrl: The **Ctrl** modifier replaces a given material with a new material on all of the product surfaces to which the first material was assigned. The new material will thus be identically assigned to all of the same surfaces as the previous material had been.

Alt: The **Alt** modifier resets the position of a material in the scene. This reset is carried out according to the surface mapping that was calculated in **Shaper**. If you have transformed the surface by the rotation or translation operating modes, using the **Alt** modifier will recalculate its original position. This command can also be combined with the **Shift** modifier to position a material according to an absolute grid determined by the surface mapping.

Ctrl+Shift: Combining the **Ctrl+Shift** modifiers gives access to the context menu containing advanced assignment options:

- Apply the material to:
 - this surface, in the visible aspect layer,
 - this surface, in the active aspect layer,
 - all of the surfaces that are currently using the same material as this surface,
 - all of the surfaces that have the same tags as this surface.
- Apply as a sticker on active aspect layer to:
 - this surface, with the choice among the mappings calculated for this surface,
 - all of the surfaces using the same material on the same mapping,
- Replace a sticker applied to this surface,
- Replace a sticker applied to this surface and to all of the visible surfaces where that sticker is also used.

Assigning Materials as Stickers

Shift: The **Shift** modifier assigns a material as a sticker. To assign a sticker to a surface, you can:

- **Shift** + drag and drop from the **Materials** editor,
- **Shift**+drag and drop from the active element in the **Matter** sidebar's material library. If multiple UV mapping have been assigned to the surface targeted by your cursor, a drop-down menu will appear allowing you to select the UV channel.

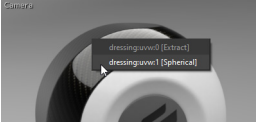



- **Shift**+drag and drop from a selected element in the **Matter** sidebar's material library. The center of the sticker is placed exactly at the location where you drop the material. Precise positioning of the sticker on the surface is accomplished using the two interactive modes.

Positioning and Orienting Materials

When a material positioning mode is enabled, it applies to all viewports. The interactive positioning begins when you click to begin to drag a material or a sticker.

The mode:

- **Translate a material**  moves the material or the sticker on the surface in an intuitive way.
- **Rotate a material**  pivots the material or the sticker around the point where you have clicked.

LIGHTING ENVIRONMENTS

A lighting environment is an omnidirectional image (360 x 360 degrees) that memorizes the incident lighting at a particular point in space.

Patchwork 3D supports the light probe, latitude-longitude, and vertical cross formats of HDR images for use as environments.



HDR Environment formats: light probe, lat-long, and vertical cross.

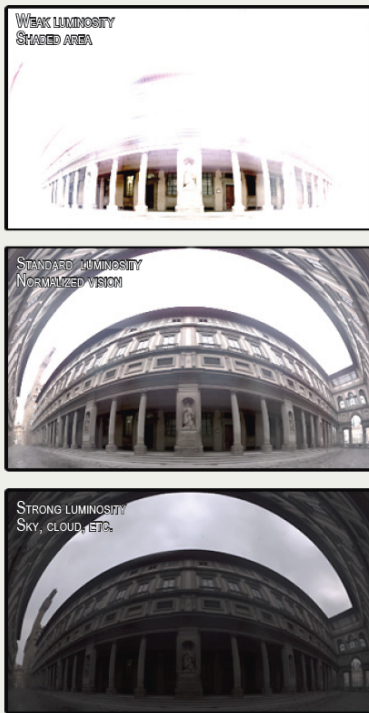

Patchwork 3D environments are HDR environments (High Dynamic Range). The data stored in an environment are encoded in order to maintain the full range of light dynamics, at multiple orders of magnitude.

The measured physical quantities of the lighting allow image details to be maintained, even within a single image, in the full range of lighting dynamics, from very dark areas to very bright ones.







With the aid of an environment, the **Matter** module computes the diffuse global lighting environment that serves to render the lighting on the surfaces and generates visible reflections in the reflection coat of the materials.

Environment Library















In the **Matter** sidebar's  library tab, the  environment library manages the groups of environments and the environments available in your database.

Groups of environments are listed in the upper part of the library:



Icon	Description
	Create a new group.
	Duplicate the selected group.
	Rename the selected group.
	Delete the selected group.











Double-clicking on the texture thumbnail makes it active and opens the texture editor.

The list of environments shows all of the existing environments in the selected group. Using the buttons below the list, you can:



Icon	Description
	Create a new environment using the HDR Light Studio Live plug-in. For more information on this plug-in, see HDR Light Studio Plug-In [243] .
	Open the HDR Light Studio Live plug-in to edit the selected environment.
	Get an HQ environment for the selected environment.
	Create a new local environment.
	Refresh all visible local environments.
	Open the Environment properties of the selected environment.
	Open the Textures editor to view the selected environment as a texture.
	Rename the selected environment.
	Refresh the selected environment.
	Import environments that you have previously saved.
	Export the selected environments. You can then choose the folder where the environments will be saved, the type of file to save (Patchwork 3D Environment , Radiance HDR or OpenEXR Bitmap) and the desired environment format (Longitude-Latitude , Vertical Cross or Light Probe).
	Duplicate the selected environment.
	Delete the selected environments.
	Purge environments that have not been used (environments that are not applied to any surface of any product).
	Modify the way in which the list is displayed.

Right-clicking on an environment opens a context menu offering the following options:

Icon	Function	Description
	Edit	Edit the selected environment by opening the HDR Light Studio Live plug-in.
	Refresh	Refresh the selected environment.

Icon	Function	Description
	High Quality Environment	Switch to a high quality environment.
	Set active	Makes the environment you have clicked active and shows it in the lower part of the library.
	View	View the environment as a texture in the Textures editor.
	Edit	Edit the selected environment by opening the Environment Properties .
	Replace with	Replace the selected environment(s) with another environment from the environment library.
 TIP This functionality is available if at least two materials already exist in the environment library.		
	Duplicate	Duplicate the selected environment.
	Rename	Rename the selected environment.
	Usage list	Show a list of all sensors to which this post-processing has been assigned.
	Export	Export the selected environment. Then choose the folder where the environment will be saved, the type of file to save (Patchwork 3D Environment , HDR radiance or OpenEXR Bitmap) and the desired format (Longitude latitude , Vertical cross or Light Probe).
	Delete	Delete the selected environment.

The active environment is shown in the lower part of the library:

Icon	Description
Thumbnail	Double-clicking on the thumbnail opens the Environment Properties editor.
	Use the eyedropper to grab an environment in a view and activate it.
	Open them Environment Properties for the active environment.
	Select the active environment in the list of environments.

Manipulating the Environment

In addition to the standard operations provided in the **Matter** sidebar's environment library, the Matter interface provides other actions, such **Environmental orientation**, **Link diffuse environment rotation**, or **Initialize environment orientation** in the environment in the **Environment Properties** editor.

- **Environmental orientation**: Found in the **Mode** menu. This tool allows you to move the environment about the product. Since the environment enables lighting of the product, it can thus be positioned so as to bring out the areas of interest, for example.
- **Diffuse environment rotation**: this operation is available from the **Product > Environment** menu. It allows the lighting to be rotated at the same time as the environment.

Manipulating the Environment from Editors

The editors **Surface Properties** (in Matter), **Product Environments**, and **Environment Properties** allow the orientation of the environment to be specified as a modification along the three axes X, Y, and Z.

Examples of Environments with a Product

We present here an object lit by two different environments, a studio environment, and an illuminated environment. Notice that even though the same geometry is represented, the environment plays a major role in the lighting of the model.



Studio type environment.

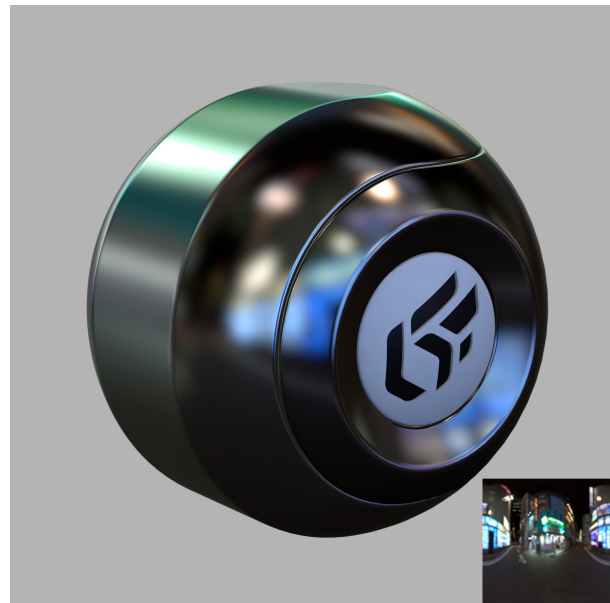

An illuminated street type environment.

It is also possible to set up a background environment. To do this, activate the **Camera** menu > **Background > Environment**. By default, the active environment is chosen.



TIP

To use an environment as a background, a sensor must be assigned to the camera in the viewport in which you want to use the environment as a background. If this is not the case, you will first need to create a sensor and drop it on the viewport.

Local Environments

Patchwork 3D supports local environments so that materials used by certain geometries can reflect their immediate, or local, surroundings.

The button **Create a local environment**  allows an environment of the **Local Environment** type to the list of available environments.

To assign this local environment to a group of surfaces, just hold the **Shift** key down and drag-and-drop the local environment onto the desired surfaces (see section Multiple Environments).



NOTE

By default, the local environment initializes at scene coordinate 0,0,0 and captures its immediate environment.

Depending on the scene, a plane or a surface can hide the environment nearest to the initial point of capture, in which case the local environment will appear dark and very few elements will be discernible.



Setting Local Environment Parameters

To show the environment around a gear lever knob in the reflection of chromed material, parameters have to be set for the local environment.

To do this, open the **Environment Properties** by double-clicking on the Active Environment thumbnail.

1. Select the **Pick the capture origin** tool  then click on a point on the gear knob to position the origin of the capture point.

2. The **Display and move the capture box** tool  allows the capture box to be displayed and moved, showing the zones from which the local environment images are going to be captured.



It is possible to adjust the size of the capture box by changing the value of the **Radius** parameter.





TIP

Capture of the environment must be consistent with the object to which the local environment is assigned.

It is therefore necessary to exclude from the capture the surfaces relating to the object:

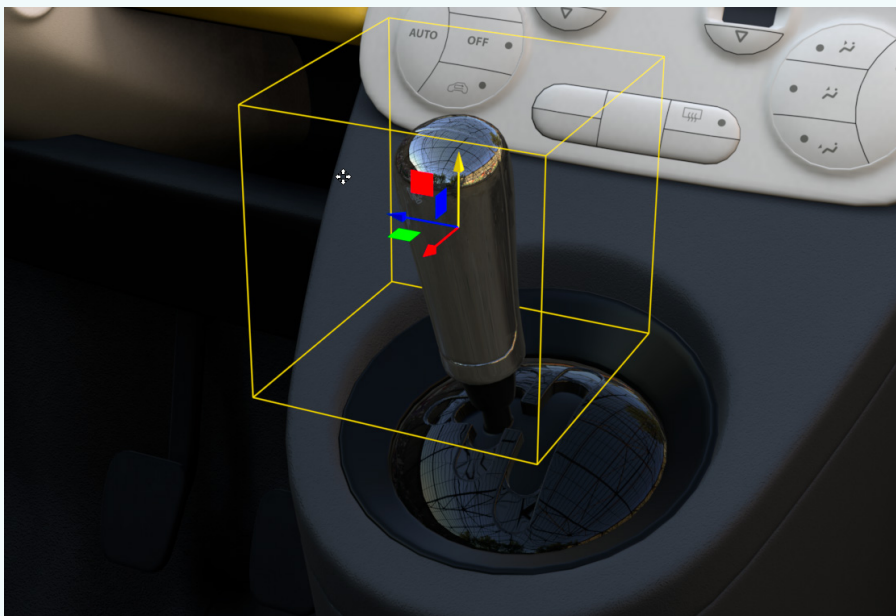
- either by using the tool for exclusion of surfaces and entering the name of the surface.
- or by ensuring that the box is larger than object in question.



- The **Refresh environment** button  allows the environment to be updated by recalculating the images captured by the local environment box.

The environment thumbnail then displays the captured environment.

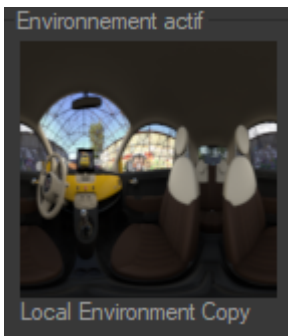

The chromed material applied to the gear lever knob reflects this new environment.



- The reflection of the environment on the material can be adjusted with precision by manipulating the value of the adjustment parameters in the **General properties** zone.

Multiple Environments

It is possible to simulate separate environments on different surfaces. To do this, drag and drop environments of your choice onto a surface while holding down the **Caps Lock** key.



TEXTURES

A texture is an image or video file used to provide a visual pattern in many different contexts.



The following image formats are supported:

- *.ktx
- *.png
- *.jpg, *.jpeg
- *.tif, *.tiff
- *.bmp
- *.tga
- *.xpm
- *.hdr
- *.exr



Video files under 1GB in the following formats are supported:

- *.avi
- *.mkv
- *.mpg, *.mpeg

Texture Library







In the **Matter** sidebar's  library tab, the  texture library manages the groups of textures and the textures available in your database.





Groups of textures are listed in the upper part of the library.

Icon	Description
	Create a new group.
	Rename the selected group.
	Delete the selected group.

Double-clicking on the texture thumbnail makes it active and opens the texture editor.

The list of textures shows all of the existing textures in the selected group. Using the buttons below the list, you can:





Icon	Description
	<p>Import textures (images or videos saved on your hard drive or on your network).</p> <p>Please find below the list of the files formats that you can import into the Texture Library:</p> <ul style="list-style-type: none"> • *.ktx (Patchwork 3D texture) • *.png • *.jpg, *.jpeg • *.tif, *.tiff • *.bmp • *.tga • *.webp • *.xpm • *.hdr • *.exr • *.avi • *.mkv • *.mpg • *.mpeg • *.mov • *.mp4
	<p>Create a new text texture by opening the Text Image editor.</p>
	<p>Duplicate the selected text texture.</p>
	<p>Edit the selected texture by opening the Textures editor or the Text Image editor, depending on the type of texture selected.</p>
	<p>Rename the selected texture.</p>
	<p>Update the selected texture.</p>





Icon	Description
	Export the selected textures. Please find below the list of the files that you can export into the Texture Library: <ul style="list-style-type: none"> • *.ktx (Patchwork 3D texture) • *.png • *.tif • *.bmp • *.tga • *.webp • *.xpm • *.hdr • *.exr
	Delete the selected textures.
	Purge textures that are not currently in use.
	Modify the way in which the list is displayed.

**TIP**

To add a texture to material just drag and drop a texture from the **Texture Library** to the Materials Editor in the dedicated field to a texture. For example **Color map, Bump, Transparency, Gradient map**. If a field already has a texture, Patchwork 3D allows you to adjust the texture size with **Absolute** or **Relative** to previous texture parameters when replacing it.

Right-clicking on a texture opens a context menu offering the following options:

Icon	Function	Description
	Edit	Edit the selected texture by opening the Textures editor or the Text Image editor, depending on the type of texture selected.
	Refresh	Update the selected texture.
	Rename	Rename the selected texture.
	Usage list	Show a list of all resources, such as textures and backgrounds, that use the selected texture.

Icon	Function	Description
	Replace with	Replace the selected texture(s) with another texture from the texture library.
<div style="background-color: #e0f2f1; padding: 10px; border-radius: 5px;">  <p>TIP This functionality is available if at least two texture already exist in the texture library.</p> </div>		
	Import	Import textures from your hard drive or from a network location.
	Export	Export the selected textures.
	Delete	Delete the selected textures.

Use text as texture

A series of characters of text can be used in all of the same contexts as an image, thanks to the internal editor that generates an image based on the text provided.

For additional information on using this function, please refer to the following sections:

- [Text Image \(Editor\) \[194\]](#)
- [Texture Library \[376\]](#)

Use video textures

Video textures can be integrated as the image used by [background \[112\]](#), the [diffuse color map in standard type materials \[326\]](#), or as [the color map of a diffuse layer in multilayer materials \[356\]](#).

To view the playback of video textures, the texture must be present in a background being used or in a material applied to a surface of a product. The texture must then be added to a [Textures \[142\]](#) track in a timeline. When a timeline containing texture clips is played, the corresponding videos are animated for the background and for all materials using those textures that are present in the active viewport.

Use animated textures

An animated texture is a sequence of images (normal textures) displayed in a loop to create the illusion of a lapping water movement, for example.

To view the playback of video textures, the texture must be present in a background being used or in a material applied to a surface of a product. The texture must then be added to a [Textures \[142\]](#) track in a timeline. When a timeline containing texture clips is played, the corresponding videos are animated for the background and for all materials using those textures that are present in the active viewport.

Patchwork 3D supports animated textures in the following materials.

Materials	Color Map	Modulation Texture	Opacity Modulator	Specular Map	Roughness Map	Bump Map
Standard	✓		✓	✓	✓	✓
Mirror	✓		✓	✓	✓	✓
Multilayer - Diffuse	✓		✓			✓
Multilayer - Specular				✓	✓	✓
Multilayer - Illumination		✓				✓

Table 1. List of materials that support animated textures.

BACKGROUNDS

A background is a 2D visual placed behind the objects in the 3D world. It does not move when you navigate in the 3D world, but remains stationary with regard to the screen.

Backgrounds are associated with camera sensors. For more information on how backgrounds are created and applied, see [Backgrounds \(Editor\) \[112\]](#) and [Sensors \[400\]](#).

In **Matter**, two types of backgrounds are available:

- **Environment** type: displays the lighting environment used to calculate the reflections and the diffuse lighting of the materials.
- **Gradient** type: replaces the uniform background of a view with a color gradient or with an image. The gradient is defined by a **Start** color and an **End** color, which are respectively associated with the top and bottom edges of the viewing zone.





Left: Gradient type background - Right: Environment type background

Assignment





To assign a **Gradient**-type background, you can:

- Drag and drop it from the start zone  in the **Backgrounds** editor.
- Drag and drop it from the active background at the bottom of the **Matter** sidebar's background library.
- Drag and drop it from the selected item of the **Matter** sidebar's background library.

Background Library









In the **Matter** sidebar's  library tab, the  background library manages the groups of backgrounds and the backgrounds available in your database.

Groups of backgrounds are listed in the upper part of the library:

Icon	Description
	Create a new group.
	Duplicate the selected group.
	Rename the selected group.
	Delete the selected group.









Double-clicking on the background thumbnail makes it active and opens the backgrounds editor.

The list of backgrounds shows all of the existing backgrounds in the selected group. Using the buttons below the list, you can:



Icon	Description
	Create a new background.
	Duplicate the selected background.
	Edit the selected background by opening the Backgrounds editor.
	Rename the selected background.
	Import backgrounds that you have previously saved.
	Export the selected backgrounds.
	Delete the selected backgrounds.
	Purge backgrounds that have not been used (backgrounds that are not assigned to any camera sensor).
	Modify the way in which the list is displayed.

Right-clicking on a background opens a context menu offering additional the following options:

Icon	Function	Description
	Set active	Make the background you have clicked active and shows it in the lower part of the library.

Icon	Function	Description
	Edit	Edit the selected background by opening the Backgrounds editor.
	Duplicate	Duplicate the selected background.
	Rename	Rename the selected background.
	Replace with	Replace the selected background(s) with another background from the background library.
 TIP This functionality is available if at least two materials already exist in the background library.		
	Usage list	Show a list of all sensors to which this background has been assigned.
	Import	Import backgrounds that you have previously saved.
	Export	Export the selected backgrounds.
	Delete	Delete the selected backgrounds.

The active background is shown in the lower part of the library:

Icon	Description
Thumbnail	Double-clicking on the thumbnail opens the Backgrounds editor.
	Use the eyedropper to pick a background from a viewport and render it active.
	Open the Backgrounds editor for the active sensor.
	Select the active background in the list of sensors.

OVERLAYS

An overlay is a 2D image (often a logo) that is displayed in front of the objects in the 3D world. It does not move when you navigate in the 3D world but remains stationary on the screen.

Overlays are associated with camera sensors. For more information on how overlays are created and applied, see [Overlays \(Editor\) \[240\]](#) and [Sensors \[400\]](#).

Overlays are managed in the **Matter** sidebar's overlay library.

Enabling Overlays

Overlays are enabled by default. They can be disabled and re-enabled using the button in the toolbar at the top of the **Matter** module.

- : Enable or disable overlay display.

Overlays in Configurations

The layers of each overlay can be used in configurations in the same manner of other types of layers in Patchwork 3D.

Configuration rules accept one or more overlay layers as targets. When a user chooses such a configuration, the configuration rule is met and the layers that are targets of the rule are displayed. The other configurable layers of the overlay are hidden.

For the effects of overlay configuration to be visible, the overlay containing the configurable layers must be assigned to an active camera sensor and overlay display must be enabled.

For more information, see the following sections:

- [Product configurations \[415\]](#)
- [Configurations \(Editor\) \[176\]](#)

Overlays in Animations



Overlay display can be handled in a timeline animation by using channel animations.

Configurations containing layers of an overlay can also be animated. To do so, use configuration keys positioned in the **Configurations** track of a timeline.



For more information, see the following sections:

- [Timelines \[449\]](#)
- [Timelines \(Editor\) \[135\]](#)
- [Channels \(Editor\) \[154\]](#)

Overlay Library









In the **Matter** sidebar's  library tab, the  overlay library manages the groups of overlays and the overlays available in your database.

Groups of overlays are listed in the upper part of the library.

Icon	Description
	Create a new group.
	Duplicate the selected group.
	Rename the selected group.
	Delete the selected group.











Double-clicking on the overlay thumbnail makes it active and opens the overlays editor.

The list of overlays shows all of the existing overlays in the selected group. Using the buttons below the list, you can:



Icon	Description
	Create a new overlay.
	Duplicate the selected overlay.
	Edit the selected overlay by opening the Overlays editor.
	Rename the selected overlay.
	Import overlays that you have previously saved.
	Export the selected overlays.
	Delete the selected overlays.
	Purge overlays that have not been used (overlays that are not assigned to any camera sensors).

Icon	Description
	Modify the way in which the list is displayed.

Right-clicking on a overlay opens a context menu offering the following options:

Icon	Function	Description
	Set active	Make the overlay you have clicked active and shows it in the lower part of the library.
	Edit	Edit the selected overlay by opening the Overlays editor.
	Duplicate	Duplicate the selected overlay.
	Rename	Rename the selected overlay.
	Usage list	Show a list of all sensors to which this overlay has been assigned.
	Replace with	Replace the selected overlay(s) with another overlay from the overlay library.
		 TIP This functionality is available if at least two materials already exist in the overlay library.
	Import	Import overlays that you have previously saved.
	Export	Export the selected overlays.
	Delete	Delete the selected overlays.

The active material is shown in the lower part of the library:

Icon	Description
Thumbnail	Double-clicking on the thumbnail opens the Overlays editor.
	Use the eyedropper to pick an overlay from a viewport and render it active.
	Open editor Overlays for active overlay.
	Select the active overlay in the list of overlays.

How to Make an Overlay

To create an overlay, you must have previously created a texture image (for example, in Photoshop) of the logo or the text you wish to display.

Begin by opening the **Overlays**  editor from the **Matter** editor toolbar.

Next, create a new layer and adjust the position of your overlay. This is managed in the **Transformation** zone, which allows you to indicate the horizontal and vertical position, and the overlay offset.



TIP

The offset of the overlay on X, Y axis can be expressed in different units and relative to the size of the image with the following parameters % **width**, % **height** and % **default**. % **default** uses height or width depending on the default orientation of the active camera.

You can also add a background color by adjusting the parameters of the **Gradient** field.

Finally, apply the texture image by drag-and-drop to the part of the Map field.

The overlay is now created, and by dragging and dropping it from the sidebar library to the viewport, you can add the overlay to the product.

There are three actions in the **Camera > Overlay** menu that allow you to hide (or display) the overlay, to edit it or to remove it from the camera sensor, namely: **Overlay visibility**, **Edit overlay** and **Delete overlay**.

Examples

Here are a few examples of overlays prepared with the same texture image, in this case the Lumiscaphe logo.





Different styles of overlay.



NOTE

For the last example, we have varied the **Alpha** parameter (transparency) for each color. It is also possible to adjust it at the start in the **Global Parameters**. In this case, the same Alpha parameter value is applied to both the background colors.

POST-PROCESSING

Post-processing filters an image to produce a certain look or effect. Patchwork 3D has a powerful 2D post-processing tool for creating, combining and inventing spectacular rendering effects. Because Patchwork 3D's post-processing is real-time, you can continue navigating in the viewport; the filter will remain in place and navigation will still be fluid.

Post-processing is managed in the **Matter** sidebar's post-processing library.

Enabling Post-Processing

Applied post-processing is displayed by default. This setting can be disabled and re-enabled using the button in the toolbar at the top of the **Matter** module.



: Enable or disable the display of 2D post-processing blends.

Post-Processing Effects

Patchwork 3D offers 17 basic effects as well as three types of tone mapping. Each has programmable properties. Effects can be added one after the other or blended together using the options in the **Advanced** sub-menu to produce a unique result.

The different basic effects are:

- Gaussian blur.
- Film grain.
- Hand drawing.
- Negative.
- Black and white.
- Sepia.
- Grayscale.
- Color filter.
- Adjust color.
- Bloom.
- Sharpen.
- Edge detector.
- Erode.
- Dilate.
- Vignetting.
- Camera response.

You will find examples of the main effects below.

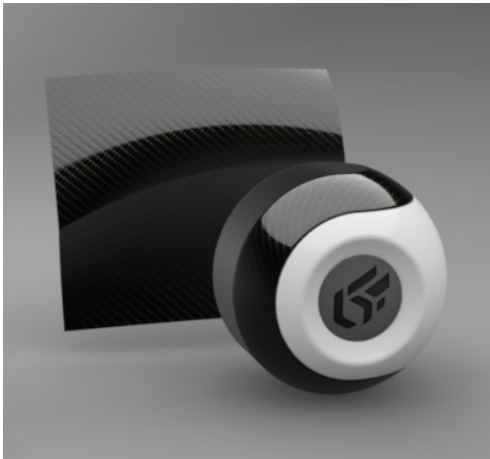

Initial image.

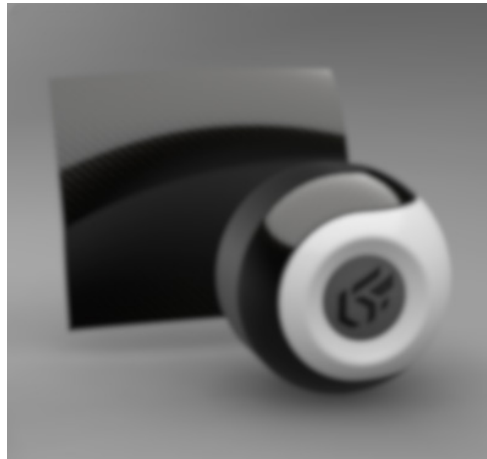

Gaussian blur.

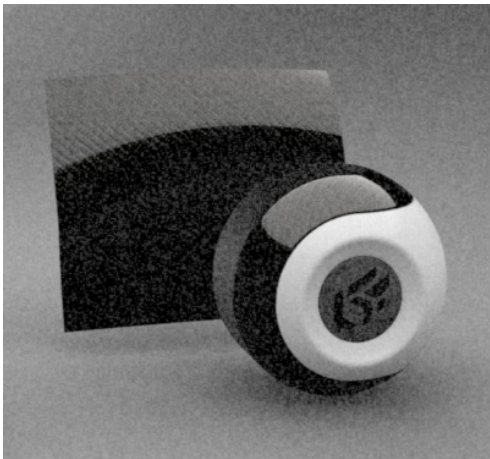

Film grain.

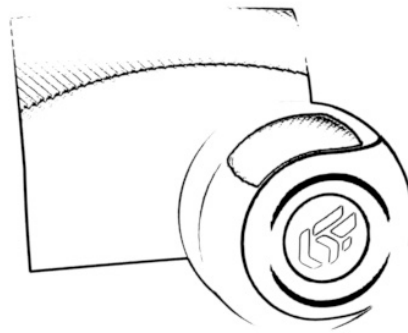

Hand drawing.



Negative.

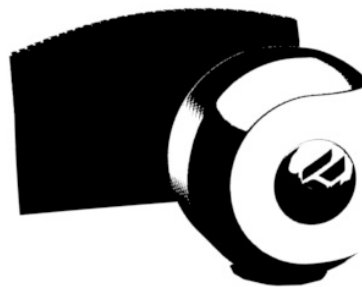

Black and white.

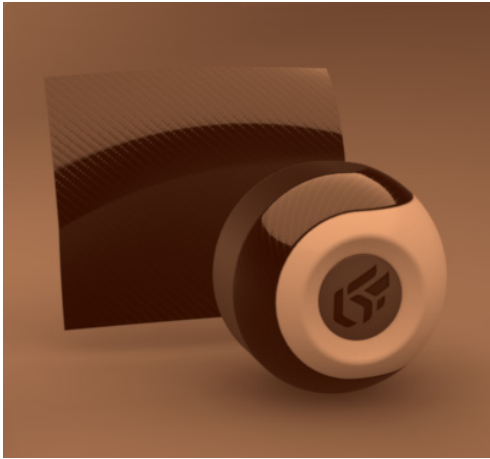

Sepia.

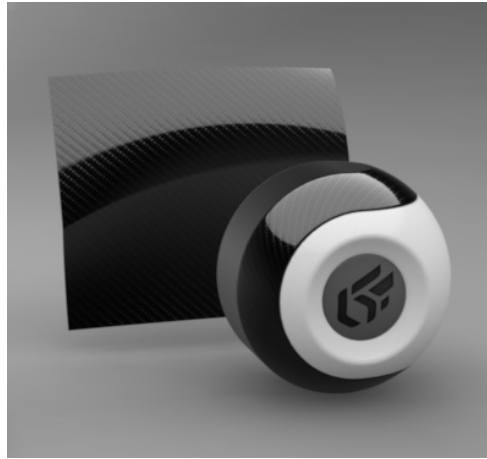

Grayscale.



Color filter.

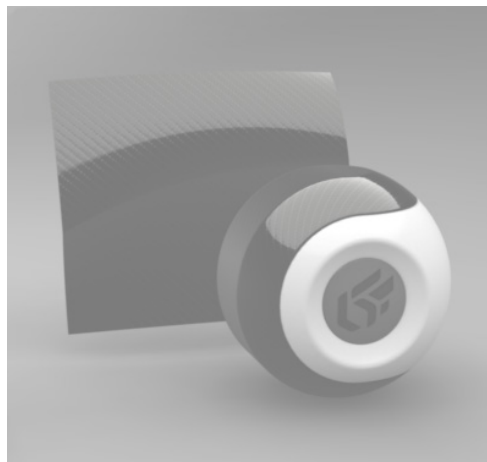

Adjust color.

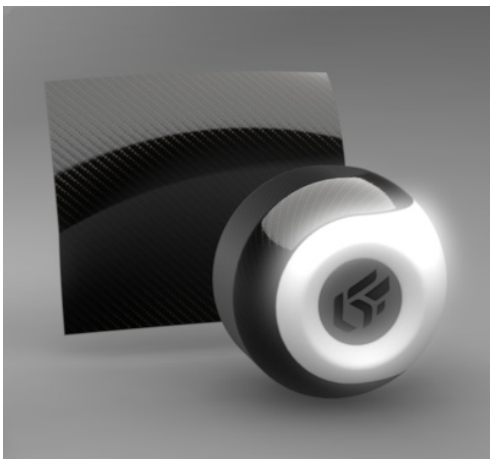

Bloom.

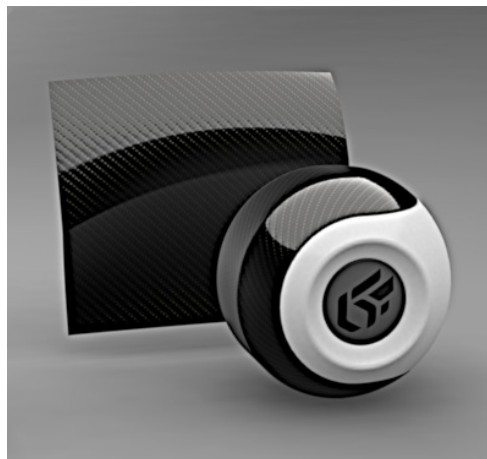

Sharpen.

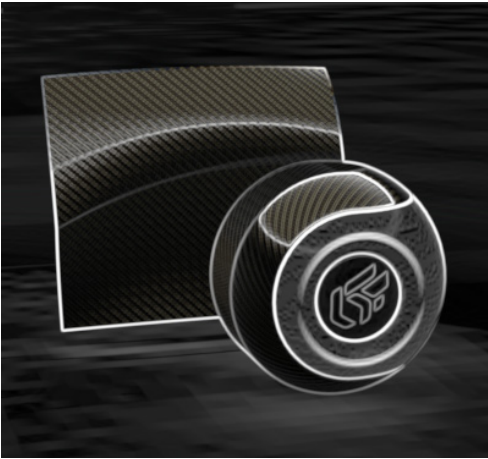

Edge detector.

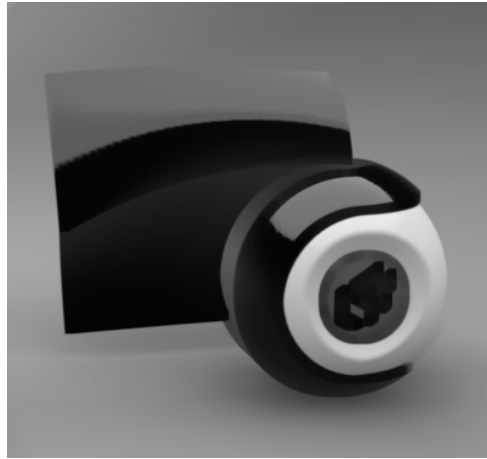

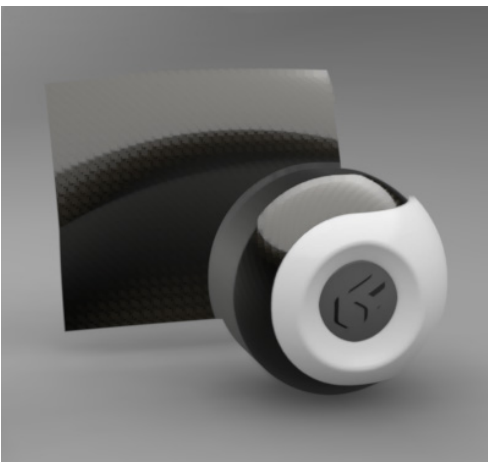

Erode.







Dilate.

Post-Processing Library









In the **Matter** sidebar's  library tab, the  post-processing library manages all post-processing effects. From this sidebar library, you can create, duplicate, save, import, and delete the post-processes you have generated.

Post-Processing Groups: Find below the available actions.



Icon	Description
	Create a new group.
	Duplicate the selected group.
	Rename the selected group.
	Delete the selected group.

Double-clicking on the post-processing thumbnail makes it active and opens the post-processing editor.



Post-Processing is the list of the available post-processing blends. Using the buttons below the list, you can:









Icon	Description
	Create a new post-processing blend.
	Duplicate the selected post-processing blend.
	Edit the selected post-processing blend by opening the Post-processing editor.
	Rename the selected post-processing blend.
	Import post-processing blends that you have previously saved.
	Export the selected post-processing blends.
	Delete the selected post-processing blends.
	Purge post-processing blends that have not been used (post-processing blends that are not assigned to any camera sensor).
	Modify the way in which the list is displayed.

The active post-processing blend is shown in the lower part of the library:

Icon	Description
Thumbnail	Double-clicking on the thumbnail opens the Post-processing editor.
	Use the eyedropper to pick a post-processing blend from a camera sensor used in a viewport and render it active.
	Edit the selected post-processing by opening the Post-processing editor.
	Select the active post-processing blend in the list of sensors.

Right-clicking on a post-process opens a context menu offering the following options:

Icon	Function	Description
	Set active	Make the post-processing you have clicked active and shows it in the lower part of the library.
	Edit	Edit the selected post-processing by opening the Post-processing editor.

Icon	Function	Description
	Duplicate	Duplicate the selected post-processing blend.
	Rename	Rename the selected group.
	Usage list	Show a list of all sensors to which this post-processing has been assigned.
	Replace with	Replace the selected post-processing with another post-processing from the post-processing library.
<div style="background-color: #e0f2f1; padding: 10px; border-radius: 5px;">  <p>TIP This functionality is available if at least two materials already exist in the post-processing library.</p> </div>		
	Import	Import post-processing blends that you have previously saved.
	Export	Export the selected post-processing blends.
	Delete	Delete the selected post-processing blends.

Tone Mapping

A tone mapping operator is a tool for displaying a High Dynamic Range image (with no intensity limitation) on a Low Dynamic Range screen (with an intensity limited to 1), which is unable to manage the range of light intensities present in the image. Using a tone mapping operator to display HDR images can reveal details otherwise invisible. However, tone mapping operators can change the appearance of the colors, shadows, and lights.

The three tone mapping effects are detailed below.



Automatic tone mapping.

PBR Neutral Tone Mapping

Available in: **Matter** module > sidebar's  library tab > **Post-Processing library**  > **New**  >
New effect  > **Tone Mapping** > **PBR Neutral Tone Mapping**

Principle

PBR Neutral Tone Mapping stabilizes tonal response and maintains color accuracy in a PBR stream, especially on reflective and emissive materials.

The PBR Neutral Tone Mapping ensures accurate material rendering that aligns with the requirements of physically based workflows. This post-processing improves the handling of lighting and color in complex 3D scenes while preserving physical realism. The PBR Neutral Tone Mapping post-processing is effective with high-contrast reflective materials, maintaining brightness while preserving color accuracy and realism.





In the use case video above, watch how reflections on the spheres, vehicle body, and ground behave with this post-processing toggled on.

<https://www.youtube.com/embed/JOMw9W2u3H0>

When to use it?

- High contrast scenes (reduced highlight clipping).
- Rendering requiring colorimetric fidelity to the diffuse color of the material.
- PBR renderings for Unity HDRP, Unreal, V-Ray, etc. (cross-engine consistency).
- Calibration/OCIO/ACES requirements (neutral output ready for LUTs).

Creating and applying an effect

1. In the right sidebar of the Patchwork 3D interface, click the **Libraries**  tab and select **Post-Processing Library** .
2. Create a new post-processing from  under the **Post-Processing** box. See also: [Post-Processing Library \[392\]](#) for more details.
3. In the **Post-Processing** editor that opens, add the effect to the active post-processing by clicking **New Effect** . Select **Tone Mapping**, and then **PBR Neutral Tone Mapping**. See also: [Post-Processing \(Editor\) \[211\]](#) for more details.

4. Apply post-processing to the active camera.

- You can activate the camera in edit mode from the **Cameras**  editor using the following procedure: [Camera List \[148\]](#).
- You can also not activate the camera in edit mode and **Apply anyway** the PBR Neutral Tone Mapping effect. However, the addition of post-treatments will not be saved in the database.

5. Check the rendering of highlights and reflective surfaces.

Reinhard Tone Mapping

Two parameters may be set for the **Reinhard Tone Mapping**: these are **Saturation** level and **Brightness** factor.

Saturation level is the input intensity level that will be brought back to 1. Setting this parameter to a high value preserves high-intensity lights.

Brightness factor enables the user to control brightness after processing. Setting this parameter to a high value leads to a light final image.

In order to use **Sub-pixel correction**, the corresponding box must be ticked. The **Sub-pixel correction** option limits aliasing phenomena in the HDR images.

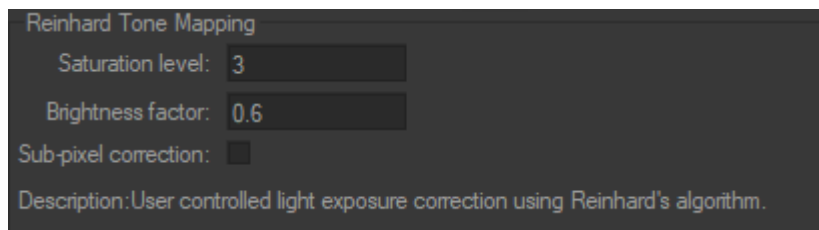

Options for the Reinhard Tone Mapping effect.

The following images show the effect of Reinhard Tone Mapping for different saturation levels and brightness factors.



A Patchwork 3D scene with no tone mapping applied.



Reinhard tone mapping with a saturation level of 0.6 and a brightness of 0.6.



Reinhard tone mapping with a saturation level of 1.5 and a brightness of 0.8.

Drago Tone Mapping

The following parameters can be set for the **Drago Tone Mapping** effect: **Average Luminance**, **Bias** and **Maximum Input Luminance**. The user may also choose to use **Sub-pixel correction** by ticking the corresponding box.

Average Luminance is for controlling the average intensity of the original image. Setting this parameter to low values leads to an overexposure of the final image.

Bias parameter enables users to control the final image contrast.

Maximum Input Luminance parameter is for controlling the maximal intensity in the original image.

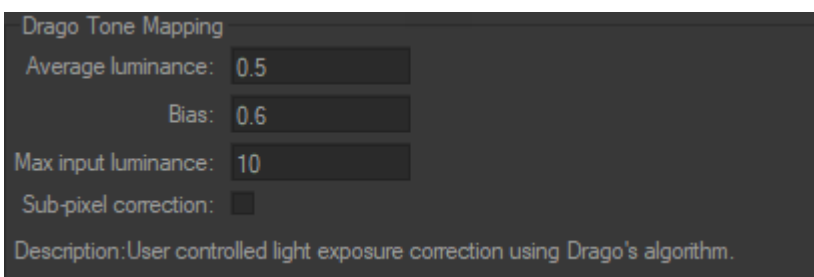

Options for the Drago Tone Mapping effect.

The following images show the effects of Drago Tone Mapping for different average luminance, bias and maximum input luminance levels.



A Patchwork 3D scene with no tone mapping applied.



Drago tone mapping with an average luminance of 0.5, a bias of 0.6 and a maximum input luminance of 10.



Drago tone mapping with an average luminance of 0.5, a bias of 0.6 and a maximum input luminance of 1.



Drago tone mapping with an average luminance of 0.5, a bias of 0.2 and a maximum input luminance of 10.

SENSORS

A sensor is one of the basic resources in **Matter** that allow you to dress a product. Sensors are used to specify view-related information, such as the aspect ratio and type of projection, and to group 2D elements applied to a rendering.

To use a sensor, you must assign it to a camera or to a viewport. Assigning a sensor to a viewport assigns it to the viewport's free camera. You can assign a sensor to as many cameras as you would like.

Sensors are managed in the **Matter** sidebar's  sensor library.

Default Values

When no sensor is assigned, a camera, including the free camera in a viewport, uses sensor default values.



The default values include an aspect ratio of 3:2, equivalent to the full-frame sensor in physical cameras measuring 24x36mm, and the use of a perspective projection. No backgrounds, overlays, or post-processing effects are used.

Attributing a New Sensor to a Viewport's Free Camera



You can attribute a different sensor to any viewport's free camera. This will replace the default sensor values in that viewport until the sensor is deleted or the viewport is closed. Remember that all viewports are closed when you close your database.

Drag the sensor that you want to use from the **Matter** sidebar's sensor library and drop it onto the view in which you would like to use it.

Sensor Library

In the **Matter** sidebar's  library tab, the  sensor library manages the groups of sensors and the sensors available in your database.









Groups of sensors are listed in the upper part of the library.

Icon	Description
	Create a new group.
	Duplicate the selected group.
	Rename the selected group.





Icon	Description
	Delete the selected group.





Double-clicking on the sensor makes it active and opens the sensor editor.

The list of sensors shows all of the existing sensors in the selected group. Using the buttons below the list, you can:



Icon	Description
	Create a new sensor.
	Duplicate the selected sensor.
	Edit the selected sensor by opening the Sensors editor.
	Rename the selected sensor.
	Import sensors that you have previously saved.
	Export the selected sensors.
	Delete the selected sensors.
	Purge sensors that have not been used (sensors that are not associated with an open viewport or with a camera).
	Modify the way in which the list is displayed.

Right-clicking on a sensor opens a context menu offering the following options:

Icon	Function	Description
	Set active	Make the sensor you have clicked active and shows it in the lower part of the library.
	Edit	Edit the selected sensor by opening the Sensors editor.
	Duplicate	Duplicate the selected sensor.
	Rename	Rename the selected sensor.
	Usage list	Show a list of all cameras using the selected sensor.

Icon	Function	Description
	Replace with	Replace the selected sensor(s) with another sensor from the sensor library.
		 TIP This functionality is available if at least two materials already exist in the sensor library.
	Import	Import sensors that you have previously saved.
	Export	Export the selected sensors.
	Delete	Delete the selected sensors.

The active sensor is shown in the lower part of the library.

Icon	Description
Thumbnail	Double-clicking on the thumbnail opens the Sensors editor.
	Use the eyedropper to pick a sensor from a viewport and render it active.
	Open editor Sensors for the active sensor.
	Select the active sensor in the list of sensors.

Using Sensors

Opening a Database from an Older Version

When you open a database created with a Patchwork 3D version prior to v6.0, sensors will be created automatically in order to conserve the settings applied to your products. The sensors created by this conversion include information for:

- Any applied post-processing and the visibility of post-processing blends,
- Any applied overlays and the visibility of overlays,
- The background mode and any applied background texture,
- The depth policy,
- The viewport policy.

Assigning a Sensor to a Camera

A sensor can be assigned to a camera or to multiple individual cameras.

In the **Camera Editor**, switch to **Edit current camera** mode for the camera to which the sensor should be assigned. Drag the sensor from the Matter sidebar's sensor library and drop it onto the **Sensor** field in the **Camera Editor**.

Assigning a Sensor to a Viewport

A sensor can be assigned to the free cameras in individual viewports. Assign a sensor to the free camera by dragging it from the Matter sidebar's material library and dropping it onto the viewport while the free camera is active. Because the free camera for each viewport functions independently, only the sensor for the free camera in the chosen viewport will be replaced.

You can verify the sensor assigned to the active viewport at any time. If a sensor has been assigned to the active camera in a viewport, it is displayed in the upper right-hand corner with the name of the camera. This information is also available in the **Camera Editor**. When a camera is active, its information is displayed on the right-hand side of the editor. The sensor used by the active camera is shown in the **Sensor** field. Click on this field to locate the sensor in the Matter sidebar's material library.

Modifying the Sensor Used in a Viewport

The sensor assigned to the camera that is active in a viewport can be modified without opening the **Sensor Editor**. To replace the sensor's current post-processes, overlays, and environments with new ones, drag and drop the new effects onto the viewport.

GEOMETRY LAYERS

Geometry layers enable the surfaces of a model to be grouped and organized in a hierarchical structure. This facilitates editing. Geometry layers can also be used with the configuration system to hide or display surfaces in a given layer.







The  **Surface** tab in the **Shaper** sidebar contains each of the surfaces contained in the layer you are editing.

Each layer is represented by a zone containing its name and its properties. All the operations that modify the state of a layer are applied by default to the active model that is shown highlighted.





Initially, a model has only one layer. You can create new layers via the **Layer > New menu**. You can then distribute the surfaces into the various layers to form logical assemblies of surfaces.

Operations on Geometry Layers

Each geometry layer is listed with several status indicators:

Indicator	Description
	Visible layer.
	Hidden layer.
	Unfrozen layer.
	Frozen layer.
	Layer that contains the active layer.
	Active layer.
	Select all surfaces in this layer in a single click.

Operations on the layers can be carried out using the buttons below the list of layers:

Icon	Description
	New layer.
	New layer within the selected layer.
	Duplicate the selected layer.
	Rename the selected layer.
	Find and select the surfaces in the selected layer.



Icon	Description
	Delete the selected layer.

Each layer has properties that directly affect the surfaces it contains. These operations are available via a right-click on the name of the layer.

The most commonly used operations are the following:

Operation	Description
Show these layers	<p>Modifies the visibility of the active layer. The surfaces in an invisible layer do not appear in the geometry of the model and cannot be modified in Shaper.</p> <p>You can use the visibility of the layers to momentarily hide the surfaces on which you are not working and to simplify accessing the other surfaces. You can also vary the visibility of the layers to test the geometrical variations of a model.</p>
Freeze these layers	<p>Modifies the editable state of the active layer. The frozen layers are still included in the geometry of the model, but can no longer be modified in Shaper. The frozen surfaces appear differently in the 3D view of Shaper: they are shaded. You should only freeze a layer when the surfaces of the layer no longer need to be edited.</p>
Duplicate	<p>Duplicates the active layer and also all of the surfaces it contains. If the active layer is not the only layer in the model, you can delete it by right clicking on the layer and choosing Delete.</p>

The principal operations on layers are also available via right-click on a geometry layer in the sidebar. The right-click context menu also provides access to the following operations, among others:

Icon	Operation	Description
	Duplicate layer with symmetry	<p>Creates a duplicate of the selected layer but reflects all of its surfaces over a given plane: YX, XZ or YZ.</p> <p>A window will open and you will be asked to choose the plane of symmetry.</p>
	Show child layers	<p>Modifies the visibility state of all child layers in order to make them visible.</p>

POSITION LAYERS

Definition

Position layers allow **Shaper** objects to have multiple positions, one in each layer. Position layers can then be used in the configuration system to create variants of a model or a product in which the position or the presence of certain objects is not the same.

Displaying Position Layers

Surfaces using position layers are displayed taking the layer hierarchy into account. Position layers indicated as visible are analyzed in the same order as they are listed in the **Position Layers** editor. For each surface, the first position assignment found is displayed.

For more information on creating position layers, see [Position Layers \(Editor\) \[147\]](#).

LIGHTING LAYERS

A lighting layer is a grouping of light information that contains multiple lights.

The lighting that is visible on a model is the result of an analysis of the stack of lighting layers. Each surface is lit based on the first visible layer in which an lighting is assigned to the surface.

Lighting layers can be used just like other layers, as targets of configuration rules. This allows, for example, indicator lights, LEDs and other lights to be turned on or off when a configuration symbol is enabled in the configuration browser, or according to the position of configuration keys in an animation timeline.

In the **Illumination**  tab in the **Shaper** sidebar, the **Illumination Layer** zone provides the tools to create, adjust, and delete layers.

Operations on Lighting Layers



TIP







There is a maximum limit to the number of lighting layers. The total number of layers must not exceed 32. Once you have reached this limit, no additional layers can be created.



TIP

To change the position of a layer in the list, drag and drop it on a new position.

The main buttons are available below the list of layers:

Icon	Description
	New lighting layer.
	Duplicate lighting layer.
	Add new lighting color to the layer.
	Rename lighting layer.
	Import lighting layer.
	Export lighting layer.
	Delete lighting layer.

The buttons to rename, duplicate, export or delete a layer affect only the selected layer. When multiple layers are selected, these buttons only affect the leader of the selection. The leader layer has a dotted border and is highlighted in light gray.

Each lighting layer has its own set of active values for modulation color, intensity, visibility, and configuration use. The active set of color values is marked with a check in the visibility column in the **Layers** list. When more than one layer is visible, the active values for each layer are combined.

The columns to the right of the name of the layer display the value of each of these properties. To change the value, click on its representation in the corresponding column.

Property	Description
Modulation color	The color of the lightmap is multiplied by the color of the layer. This color is always white by default. Click on the colored rectangle to open the color chooser and modify the color.
Intensity	The intensity of the lighting can be modified. You can set it to 0 or to any positive decimal value. By default, the intensity is set to 1, which represents a normal lighting.
Visibility	Illumination layers can be visible or hidden. During the analysis of the stack of layers, hidden layers are skipped. New layers are visible by default. Lights in a visible layer are shown in blue in the viewport. Lights in an invisible layer produce no effect and are displayed in red in the viewport.
Configuration	If the layer is used as a target of a configuration rule, the icon  displayed. Clicking on this icon will select the corresponding rule in the Configuration Editor .

You can also right-click on a lighting layer in order to copy its lightmaps to another layer in the list.



TIP

When you open a database created with a version of Patchwork 3D prior to version 6.0, each lighting set is converted to a lighting layer. To maintain the original settings, the layer that corresponds to the active lighting set is visible; all of the other layers are hidden.



TIP

When a new lightmap is first calculated for a surface, the other lightmaps for this surface may also need to be recalculated if they were generated with a version of Patchwork 3D prior to version 6.0.

Using Lighting Layers

Illumination layers can require significant computing power. To limit this, lighting layers have been optimized for certain uses.

Substitution

Use a lighting layer when you have multiple geometric versions of your model. For example, you might be working on a seat that can be marketed with or without a headrest. Without a lighting layer, you must calculate the lightmap for the whole model. When you view the version with no headrest, however, the zone where the headrest would have been remains black: no lightmap was calculated for this zone.

To correct this, use a lighting layer.

Configuration

Use a lighting layer when your light sources need to be animated or configurable.

Put only the lights that must be turned on or off together in a separate layer.

The activation of layers is configurable. As with other types of layers, lighting layers can be dropped onto the **Configurations** editor.

The set of color and intensity values of each layer is also configurable. The lighting color set can also be dropped onto the **Configurations** editor.

Recommendations

To improve performance, follow these recommendations:

- Put all related lights in the same layer.
- Make sure that it isn't possible to have multiple layers containing sky lights active at the same time.
- Use the minimum number of layers that you can.
- Avoid using multiple sky lights to create the effect of an exterior environment. This effect can be created in **Matter** with a [lighting environment \[367\]](#) and a [real-time sun \[235\]](#).

Settings for a Lighting Layer

Select a lighting layer by clicking on it. The light sources in this layer are now shown in white in the viewport. They are also listed below in the **Lighting Settings** zone.

In addition to the lights contained in the layer, layers also contain additional settings that determine the aspect of their illumination. These settings are found in the **Lighting Settings** zone. They apply to all lights in the layer.

- **Exposure**
- **Gamma**
- **Lightmap format:**
 - **Color:** To obtain shadow rendering that takes the lighting colors into account, choose the **Color** format.
 - **Luminance (8 Bits):** Use the **Luminance (8 bits)** format to obtain a relatively rapid rendering.
 - **Luminance HQ (16 bits)**
 - **Luminance HDR (16 bits):** The **Luminance HDR (16 bits)** lightmap texture format is designed for the shadow rendering of HDR images and manages light sources significantly more intense than the **Luminance (8 bits)** and **Luminance HQ (16 bits)** formats.
- The  lighting settings:
 - The **resolution** of the textures to be produced,
 - The size of **shadowmaps**,
 - The choice to render the unlit surfaces using **Environment**-type lighting.

ENVIRONMENT LAYERS

Environment layers allow for the creation of several product variants with different environments and can be used in configurations.

You may be interested in learning more about:

- [Product Environments \(Editor\) \[183\]](#)
- [Lighting environments \[367\]](#)

Using Environment Layers

The principle of using environment layers is best illustrated through an example.

First, a layer named "Dock Layer" is created in which a global environment is allocated to all surfaces.

A second layer named "Warehouse Layer" is created, in which a global environment is allocated to all surfaces.

Finally, we create a layer "Body Layer" containing an environment assignment specific to the body.

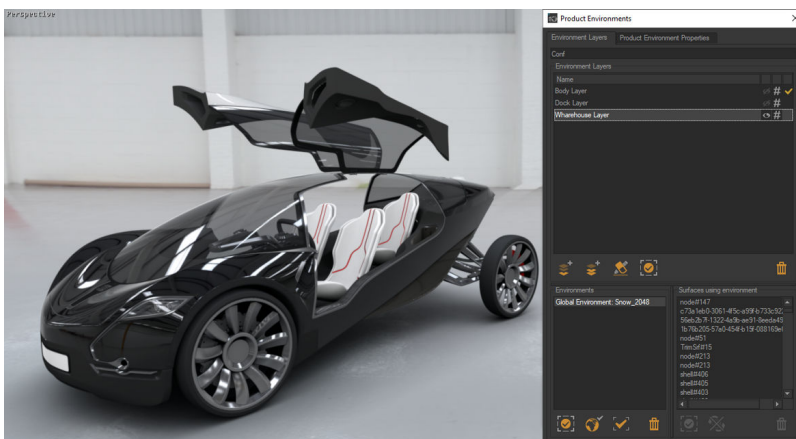
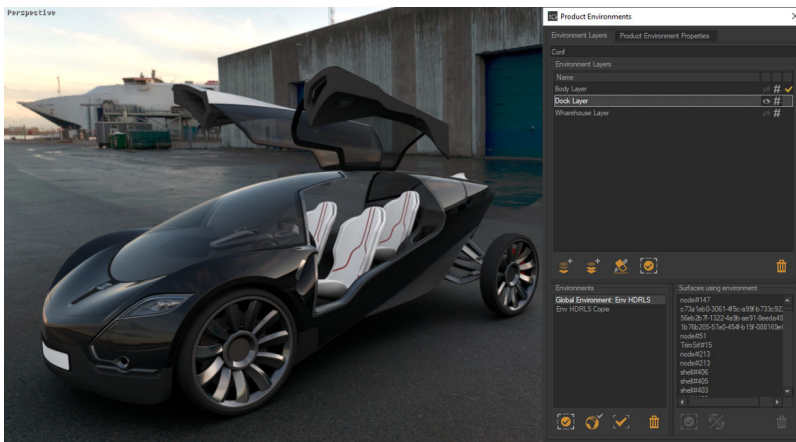

ASPECT LAYERS

Aspect layers allow different materials and their UV mapping projections to be assigned to the same surface in different layers.

Using aspect layers will allow you to create configurations for the materials used to dress your product. This approach makes it easy to create many variants and derived versions of products.

You may be interested in learning more about:

- [Aspect Layers \(Editor\) \[143\]](#)

Accessing All Aspect Layers with Assignments

Once a surface is selected, it is possible to obtain the list of aspect layers in which there's a material or one or more labels assigned to it.

This list may be reviewed in the **Surface Properties** accessed by right-clicking on a surface and selecting **Edit properties**.

For each aspect layer in the list, the following attributes are displayed:

- The aspect layer's name,
- The mention **hidden** if the layer is not visible,
- The number of material assignments for the selected surface in the layer if relevant,
- The number of sticker assignments for the selected surface in the layer if relevant.

Selecting an aspect layer in the list displays the corresponding assignments in the **Layer Assignments** box.

Moving Material and Sticker Assignments

Material and sticker assignments may be moved from one aspect layer to another.

Moving a material or sticker assignment is performed by selecting the source aspect layer in the **Layer** drop-down list of the **Surface Properties** accessed by right-clicking on a surface and selecting **Edit properties**.

Material and sticker assignments defined in the selected layer are displayed in the **Layer Assignments** box. The assignment to be moved must then be selected and the destination aspect layer chosen from

the list opened by clicking the **Move Assignment** button .

LIVE MODE

Available in: **Matter**: main toolbar >  **Live Mode**

The **Live Mode** is a visualization and presentation mode that allows you to interact with digital aspect mockups and explore different product configurations.

In this mode you will be able to:

- View your products.
Patchwork 3D has different views allowing you to interactively inspect the design of a product.
- Compare different 3D products or different configurations of a single product.
Several view configurations (**Viewport** menu) are available to view products side by side. This approach allows the simultaneous comparison of several elements of a product line. The [links between views \[94\]](#) are provided to facilitate this 3D comparison.
- Interact with elements of your products using animation triggers.



TIP

It is necessary to have previously created at least one clip or a timeline in the **Timelines** editor to be able to create triggers.

Please refer to the chapter on [Live Mode \(Editor\) \[197\]](#) for how to create triggers.



TIP

To exit the Live Mode, click the button  in the main toolbar of **Matter**.

PRODUCT CONFIGURATIONS

The product configuration system in Patchwork 3D is designed to offer the possibility of displaying product variants in real time. The configuration tools allow you to elaborate a complete product range. This range can then be used directly by our configuration exploration software programs, such as Patchwork Explorer and Web Render.

The configuration system requires the use of geometry, aspect, position, environment, illumination, or lighting color layers. A minimum level of knowledge is necessary to manipulate and use the configuration features of Patchwork 3D to the best effect.

To obtain a configuration system, you should build [geometry \[404\]](#), [illumination \[407\]](#), [lighting color \[408\]](#), [aspect \[143\]](#), [position \[147\]](#), [overlay \[240\]](#), and [environment \[183\]](#) layers and create combination rules by dividing a model into several layer groups, that is to say, by partitioning it. Product variants are combinations of these layers.

Definitions used in Configurations

- **Partition:** A partition is an element or aspect of a product that can have several alternatives. A partition includes all of the possible states, either "enabled" or "disabled," or a user-defined list of states.



The truck's bin color is a partition with three states: red, gray, and blue.

- **Symbol:** A symbol is a variable that represents a selection state in the *Configuration Browser* [199]. Symbols are not created directly; they are automatically extracted from rules.
- **Defining a symbol:** The *Configuration Browser* [199] allows a set of symbols to be chosen via checkboxes and drop-down lists. Only one symbol per partition can be "defined" (selected) at a given time.

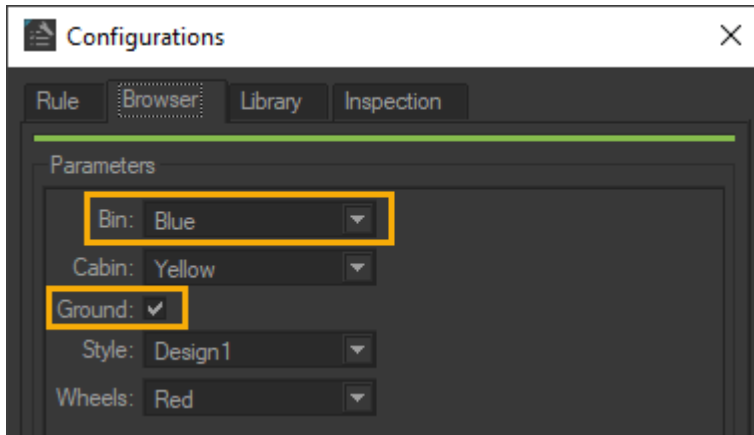

Two defined symbols in the Configuration Browser: Bin.Blue and Ground.

- **Rule:** A rule is a logical expression that links user selections in the *Configuration Browser* [199] to the visibility state—displayed or hidden—of layers. Rules are conditions that depend on a set of symbols being defined (selected in the *Configuration Browser* [199]). When the condition is fulfilled, the layers associated with the rule are visible. If one or more symbols needed to validate the rule are not defined, the layers will not be visible.
 - **Simple rule:** A rule is called "simple" when a single symbol is necessary to validate it and the only operator used is "defined".
Ground (defined "Ground")
 - **Complex rule:** A rule is called "complex" when its validation depends on the analysis of a Boolean operation.
This rule is validated when "Ground" is defined, that is, when it is selected by the user in the *Configuration Browser* [199].
`Roof_Rails(and (defined "Roof_Accessories")(not (defined "Convertible")))`
This rule is validated when "Roof_Accessories" is defined, that is, selected in the *Configuration Browser* [199], and "Convertible" is not.

Preparing a Model

A configuration, or product variant, consists of a set of layers.

Creating a variant can be thought of as defining which layers among those you have prepared will be visible and which will be hidden. Consequently, creating configurations depends on having prepared product layers before you define the configuration rules.

Sections *Understanding Partitions* [417] and *Using Meaningful Layer Names* [417] will help you think about layers used in configurations, and how to name and group layers in order to create configurations.

If you need more information on creating layers, documentation dedicated to aspect, position, and environment layers is available.

Understanding Partitions



A partition with three possible states.

To create a configurable model, begin by identifying the partitions within which several alternatives are possible. In the above image, the truck's bin can exist in multiple colors. The bin color is an example of a partition. Partitions can be related to model surface geometry, aspect or position, or the environment of the model. In this example, for ease of understanding, aspects, and colors are used to illustrate the principles of configurations.

There are two types of partitions. Some can be enabled or disabled, while others require an element to be chosen from a list of multiple alternatives. Partitions are listed in the Configuration Browser, where you or your end user can select their state:

Next, the partitions must be associated with rules.

In the above image, the partition "**stickers**" can be enabled or disabled. By ticking the checkbox "stickers" (on the left in the image), you define the corresponding symbol. The associated rule, "stickers" (on the right), states that when the symbol "stickers" is defined, the aspect layer containing the stickers is visible.

In this image, the partition "**paint**" refers to the color of the paint, which can be any one of several options: red, blue, yellow, black... By making a selection in the drop-down list (on the left of the image), you define one of the symbols "**paint.red**", "**paint.blue**", "**paint.yellow**", "**paint.black**" in accordance with your choice. The associated rules (on the right), "**paint.red**", "**paint.blue**", "**paint.yellow**", "**paint.black**," state that if the corresponding symbol is defined, the layer with the right color is visible.

This example, therefore, contains a total of five symbols and five rules (one for the **stickers** and four for the **paint**), but only two partitions ("stickers", and "paint").

Using Meaningful Layer Names

It is highly recommended that you give your geometry, position, illumination, aspect, overlay, and environment layers meaningful names. A meaningful name expresses the layer's function clearly. This will greatly simplify the procedure of creating target layers for the rules governing your configurations.

Where configurations are concerned, using meaningful names does not only mean using names that allow you to remember what the layer is and does. It also means using names that allow you to make the connection between the layers themselves and the eventual configuration symbols and partitions that you will create.

Name your layers according to the partition they will belong to.

Give the same prefix to all layers referring to the same configurable element, or partition. If the layer is part of a group of options in a single partition, like the paint partition in the example above, we recommend using a multi-part name constructed as follows:

- use the partition name as a prefix,
- followed by a point (.),
- followed by a meaningful descriptor.

This will lead to layer names such as "**paint.red**" for an aspect layer with red paint, or "**lever.raised**" for a position layer in which a lever is in the up position.

When you create configuration rules, you will be able to use meaningful layer names to **automatically generate simple rules [420]** and their symbols in the appropriate format.

If you wish to rename an aspect layer, Patchwork 3D will then suggest that you rename the configuration rules and the linked symbols for you. Patchwork 3D will also offer to rename the symbols when a configuration rule changes its name.

Configuration Rules

The configuration system is based on user-defined rules. These rules establish the visibility of the layers that they are associated with. These associated layers are called target layers. Consequently, your model must be **organized into meaningful layers [416]** before you set up your configuration rules.

Definition of a Rule

Configuration rules are the expressions that determine which options to display, and under which conditions to display them.

Configuration rules are expressed as Boolean expressions. A rule consists of:

- The definition of one or more symbols in the form "**partition**" or "**partition.value_n**". Each symbol represents a condition that can be true or false based on selections made by the end user.
- Optionally, the logical operators (AND, OR, NOT, XOR) that express relations between the symbols.
- The assignment of target layers.

Rules are evaluated logically. This evaluation leads to one of two values: true or false. When a rule is true, the rule's target layers are visible. Otherwise, they are hidden.

Using the **Configuration Browser** in this software and other display software, you or your end user can select the options to display. This selection determines which simple rules are defined, and which are not defined. The evaluation of complex rules is carried out based on these user-indicated definitions.

You can create as many rules as necessary in order to create a complete range from a base product.

Understanding Functional Principles of Symbols

All symbols follow one of two functional principles:

- **Activation/Deactivation Principle**

These symbols take the form "**partition**". They are activated or deactivated individually.

- **Exclusion Principle**

These symbols take the form "**partition.value_n**". They are grouped by their prefix "**partition.**". Activating a symbol in the same group excludes all other symbols.

When creating a rule, you determine which principle will be followed by giving the appropriate format to the symbol used in the rule.

Activation/Deactivation Principle: "partition" Symbols

All "**partition**" symbols follow the activation/deactivation principle.

They represent partitions that can be activated or deactivated. You might have symbols **armrests** and **headrest** and **footrest** for a seat product. Any, all, or none may be selected at a given time: your product variants could include a seat with both a footrest and a headrest without causing a conflict.

Each "**partition**" symbol may be either defined (true) or undefined (false) independently from other "partition" symbols, unless restricted by a complex rule. Many "**partition**" symbols may be defined, or selected, at the same time. The visibility of the target for each of the rules is activated or deactivated separately.

Once your simple rules for defining "**partition**" symbols are set up, the **Configuration Browser** will present you with a sticker "**partition**" and a check box to activate or deactivate the symbol for each rule of this type.



Checkbox for a "**partition**" sticker in the **Configuration Browser**

Exclusion Principle: "partition.value_n" Symbols

All "**partition.value_n**" symbols follow the exclusion principle.

They represent partitions that can have many values, such as the color of paint or the position of a moving part. You might have paint symbols **paint.red**, **paint.blue**, **paint.yellow** or position symbols **position.up**, **position.middle**, **position.down**.

Only one of these symbols can be selected at a given time: the paint cannot be both red and yellow at the same time; the part cannot be in both its up position and its middle position at the same time. Only one "**partition.value_n**" symbol can be defined, or selected, at a time.

The **Configuration Browser** will group these symbols by their "**partition.**" prefix. For each prefix, it will present you with a sticker "**partition**" and a choice from a drop-down list for all of the corresponding "**value_n**" rules. You may choose only one "**value_n**" to activate at a time.

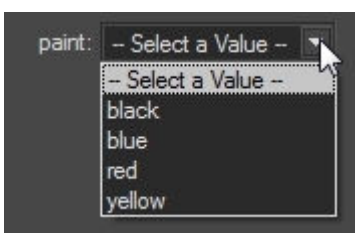

A drop-down list of "value_n" values in the *Configuration Browser*.

Creating Simple Rules

A simple rule is a rule that is evaluated as true when the symbol it uses is selected by the user. If the simple rule is evaluated as true, its target layers are displayed.

Simple rules contain only one symbol. They do not contain logical operators or relationships between symbols.

Creating Simple Rules by Dragging and Dropping

Creating "*partition*" Rules by Dragging and Dropping

To create a "*partition*" rule with a symbol that follows the activation/deactivation principle, drag and drop a single target layer onto the rule list in the *Configuration Editor*. It will follow the [activation/deactivation principle \[419\]](#) by default.

1. Open the *Configuration Editor*. Go to the *Editors* menu > *Create configurations* .
2. Select a layer that you want to use as a target layer from any of the following:
 - *Shaper*: the model's *Geometry Layers* list in the sidebar,
 - *Shaper*: the model's *Illumination Layers* and their colors from the list in the sidebar,
 - *Shaper / Matter: Position Layers* editor,
 - *Matter: Aspect Layers* editor,
 - *Matter: Environment Layers* list in the *Product Environments* editor.
 - *Matter: Overlay Layers* list in the *Overlays* editor,

3. Drag the selected layer onto the **Rules** box in the **Configurations** editor. The **Simple Rules** editor will appear.

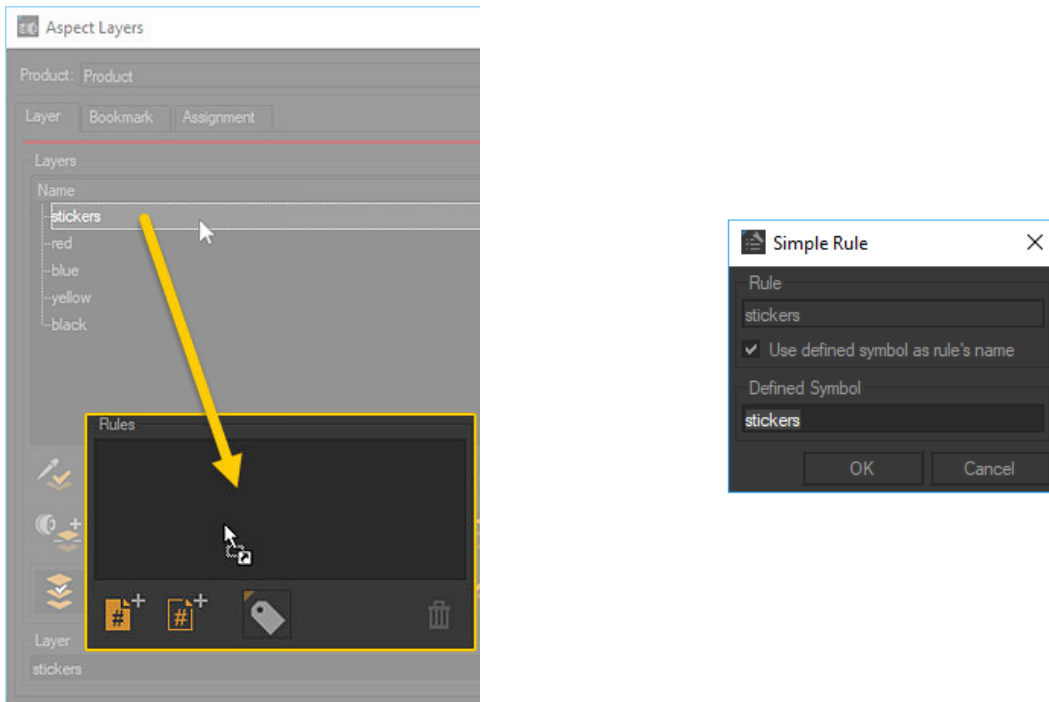

Dragging and dropping an aspect layer into the Rules zone makes the Simple Rules editor appear.

4. In the **Simple Rules** editor, you can rename the symbol that will be automatically added to the **Configuration Browser**. The name of the layer is proposed by default. You can also rename the rule itself by unticking the checkbox **Use defined symbol as rule's name**. Even if you rename the rule or the symbol, the name of the layer itself will remain unchanged.



NOTE

This method creates a single simple rule for a "**partition**" symbol that will follow the activation/deactivation principle.

It is not possible to create multiple simple rules for multiple "**partition**" symbols at the same time. Dragging and dropping a selection of layers will create a group of rules for "**partition.value_n**" symbols that follow the exclusion principle.

Creating "**partition.value_n**" Rules by Dragging and Dropping

To create a set of simple rules for "**partition.value_n**" symbols that follow the exclusion principle, drag and drop multiple target layers together onto the rule list in the **Configurations** editor. This will create multiple rules simultaneously. They will follow the **exclusion principle** [419] by default.

1. Open the **Configuration** editor. Go to the **Editors** menu > **Create configurations**.



2. Select a group of layers that you want to use as target layers from any of the following:
 - **Shaper**: the model's **Geometry Layers** list in the sidebar,
 - **Shaper**: the model's **Illumination Layers** and their colors from the list in the sidebar,
 - **Shaper / Matter: Position Layers** editor,
 - **Matter: Aspect Layers** editor,
 - **Matter: Environment Layers** list in the **Product Environments** editor.
 - **Matter: Overlay Layers** list in the **Overlays** editor,
3. Drag the selected layer onto the **Rules** box in the **Configurations** editor. The **Parameters** editor will appear.

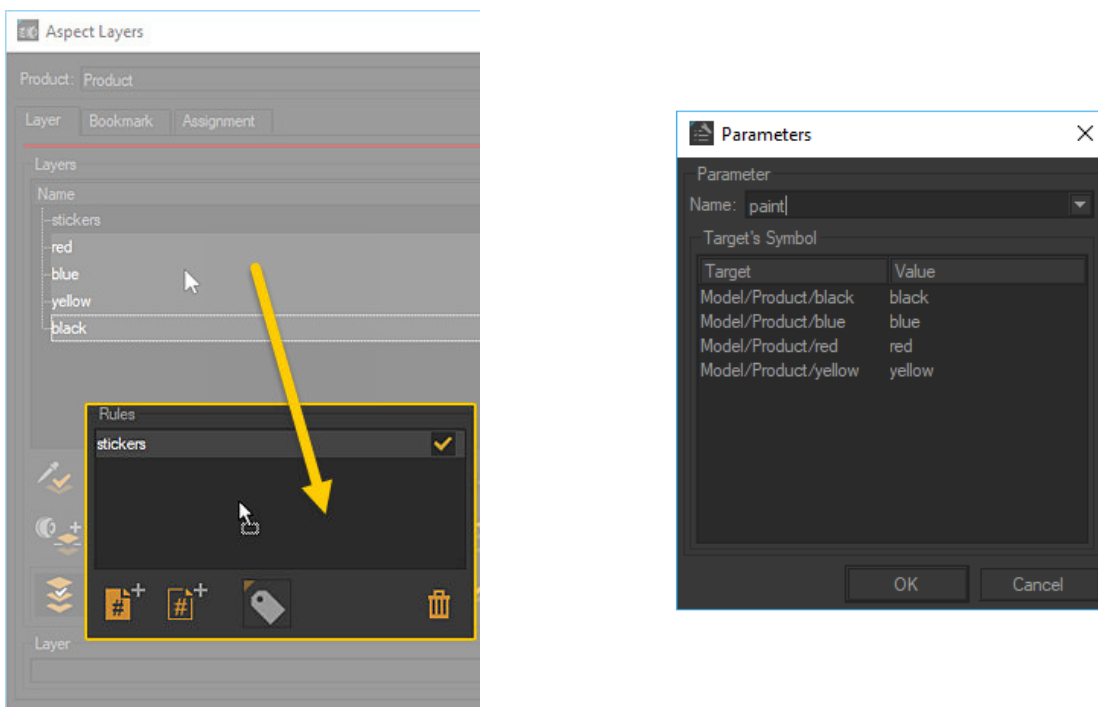

Dragging and dropping a selection of aspect layers into the Rules zone makes the Parameter Editor appear.

4. If the layer names are not in "**partition.value_n**" format, the **Parameters** editor requires that you provide the prefix "**partition**" to use for the set of symbols generated from these layers.



NOTE

This method creates a single partition with a single "**partition.**" prefix for the set of layers being dragged and dropped.

It is not possible to create sets of "partition.value_n" symbols with different prefixes simultaneously.

- Provide value labels for each individual rule. If your layer names were already in "**partition.value_n**" format, the **Parameters** editor will propose the "**value_n**" value for each layer as the value label. The names of the layers themselves will remain unchanged.

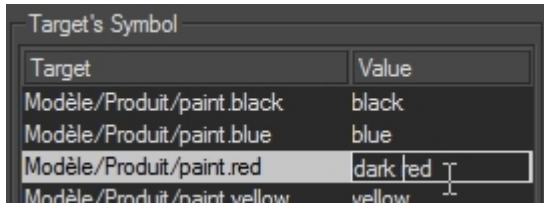

Target	Value
Modèle/Produit/paint.black	black
Modèle/Produit/paint.blue	blue
Modèle/Produit/paint.red	dark red
Modèle/Produit/paint.yellow	yellow

Renaming a value label.

Creating "**partition.value_n**" Rules by Dragging and Dropping a group of layers

To create a set of simple rules for "**partition.value_n**" symbols that follow the exclusion principle, drag and drop multiple target layers together onto the rule list in the **Configurations** editor. This will create multiple rules simultaneously. They will follow the **exclusion principle** [419] by default.

- Open the **Configuration** editor. Go to the **Editors** menu > **Create configurations** .
- Select a group of layers that you want to use as target layers from **Matter: Aspect Layers editor**.
- Drag the selected layer onto the **Rules** box in the **Configurations** editor. The **Parameters** editor will appear.

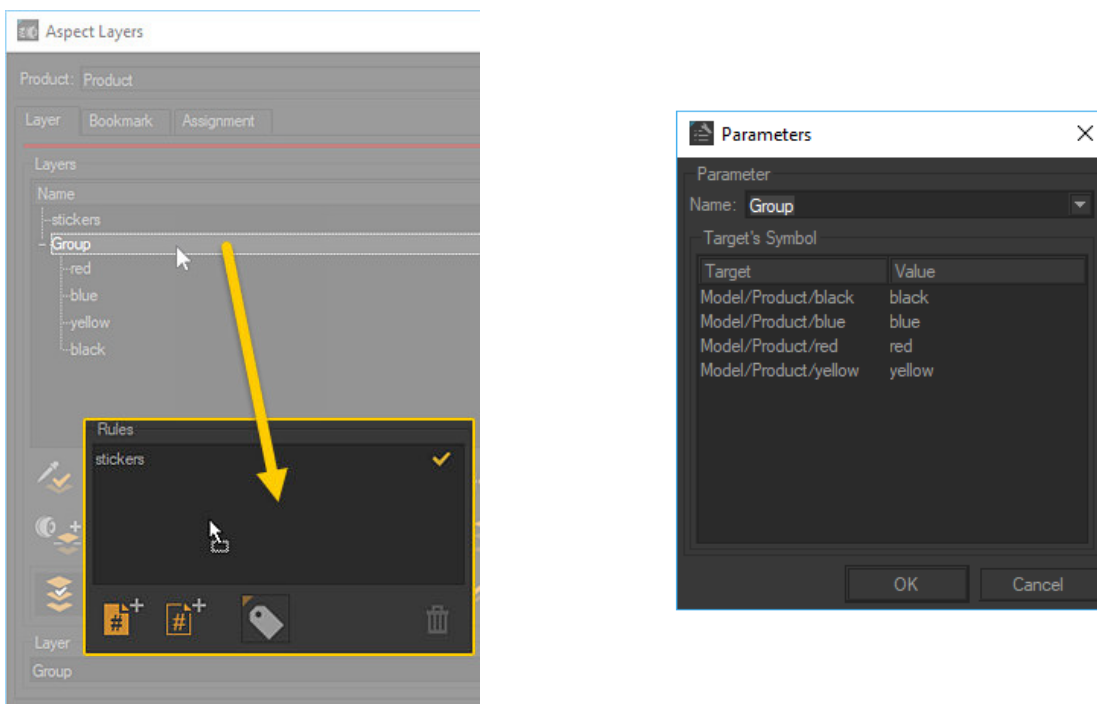

Dragging and dropping a selection of aspect layers into the Rules zone makes the Parameter Editor appear.



TIP

Drag and drop into the box **Rules** create a single partition with a single prefix "**partition.**" for all appearance layers for groups and subgroups.

Adding Targets to Existing Rules by Dragging and Dropping



TIP

Aspect and environment layers are stored at the product level. This means that a given aspect or environment level only affects the product with which it is associated. To apply the rule to several products, add the appropriate target layers for each additional product.



TIP

To ensure visibility of configurations with overlay layers, the overlay in question must be assigned to a sensor used in the viewport camera. Overlay display must be enabled.

Once a rule is created, you can also add additional target layers:

1. In the **rule** list of the **Configurations** editor, select the rule you want to add target layers to.
2. Drag and drop the additional target layers onto the **Target** list.



WARNING

You cannot use a given layer as the target for two different rules.

To express the condition set up in the following case:



- If the symbol "**partition.value1**" is defined, display layer A.
- If the symbol "**partition.value2**" is defined, display layer A.

Use a single complex rule:

- If the symbol "**partition.value1**" or the symbol "**partition.value2**" is defined, show layer A.

Creating Simple Rules Manually

To create a simple rule, use the **New Simple Rule** button in the **Configurations** editor.

1. Open the **Configuration** editor. Go to the **Editors** menu > **Create configurations** .
2. Click on the  **New Simple Rule** button. The **Simple Rule** editor will appear.

3. In the **Defined Symbol** text zone, enter the name of the symbol you want to create.
 - Use the format "**partition**" to create a symbol that will follow the [activation/deactivation \[419\]](#) principle. This will create a partition and add a checkbox in the **Configuration Browser**.
 - Use the format "**partition.value_n**" to create a symbol that will follow the [exclusion principle \[419\]](#). Create multiple rules with symbols that share the same "**partition.**" prefix to add them to the same partition and populate the same drop-down list in the **Configuration Browser**.

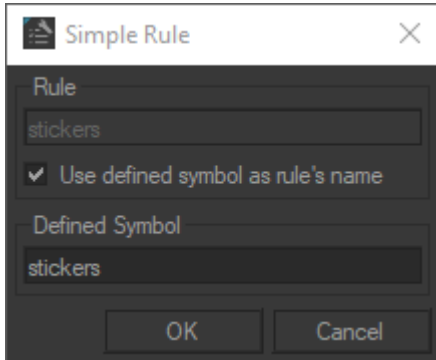

Defining a "**partition**" type simple rule.

4. The name of the symbol is used by default as the name of the rule. To change the name of the rule, uncheck the option **Use the defined symbol as the name of the rule**. Provide a new name in the **Rule** text zone.

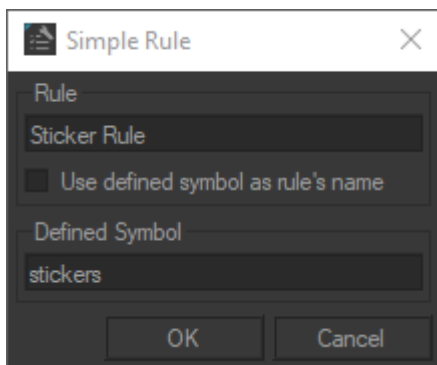

Renaming a simple rule.

5. Confirm by clicking on **OK**.

Your rule has been created, but you still need to assign target layers to it:

1. Return to the **Configurations** editor. In the rules list, select the rule you have just created.
2. Drag and drop your desired target layers onto the **Target** list. You can drag layers from any of the following:
 - **Shaper**: the model's **Geometry Layers** list in the sidebar,
 - **Shaper**: the model's **Illumination Layers** and their colors from the list in the sidebar,
 - **Shaper / Matter: Position Layers** editor,
 - **Matter: Aspect Layers** editor,
 - **Matter: Environment Layers** list in the **Product Environments** editor.
 - **Matter: Overlay Layers** list in the **Overlays** editor,

**WARNING**

You cannot use a given layer as the target for two different rules.

To express the condition set up in the following case:

- If the symbol "**partition.value1**" is defined, display layer A.
- If the symbol "**partition.value2**" is defined, display layer A.

Use a single complex rule:

- If the symbol "**partition.value1**" or the symbol "**partition.value2**" is defined, show layer A.

Creating Complex Rules

A complex rule establishes the relationships between defined symbols using the logical operators "and", "or", "not" and "xor". If the conditions are met, the rule is evaluated as true and the target layers are displayed.

Complex rules are created manually by typing the desired expressions. To create a complex rule, use the **New Complex Rule** button in the **Configurations** editor.

1. Open the **Configuration** editor. Go to the **Editors** menu > **Create configurations**



2. Click on the button  **New complex rule**. The editor **Complex rules** will be displayed.

3. In the first text box, the editor will suggest a default name for your rule. Replace "**Rule**" by an explicit name which clearly expresses the function of the rule.

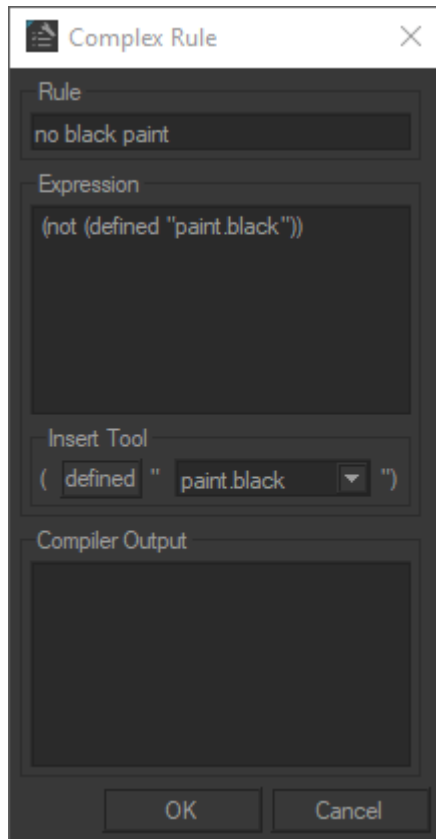

Replacing "**Rule**" with a meaningful rule name.

4. In the **Expression** text box, type out the Boolean expression. Refer to the chapter on [Rule Syntax \[428\]](#) for more information on expression syntax.
5. You can use the **Insert Tool** to insert simple rule expression within your complex rule:
- Select the desired existing symbol from the drop-down list.
 - Click "**defined**" to insert the expression at the current cursor location in the **Expression** text box.

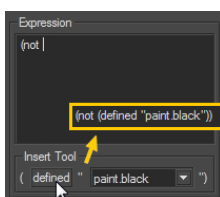

Using the **Insert Tool** to insert the simple expression "(**define** "paint.black")" in a complex expression.

6. Click **OK** to validate your rule. If the rule cannot be validated, the validation problems will be listed in the **Compiler Output** box. These problems must be corrected before you can validate your rule.

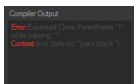

Compiler output error for missing final parenthesis.



TIP

The tools found in the [Inspection \[178\]](#) tab are particularly helpful in analyzing the evaluation of complex rules.

Your rule has been created, but you still need to assign target layers to it:

1. Return to the **Configurations** editor. In the rules list, select the rule you have just created.
2. Drag and drop your desired target layers onto the **Target** list. You can drag layers from any of the following:
 - **Shaper**: the model's **Geometry Layers** list in the sidebar,
 - **Shaper**: the model's **Illumination Layers** and their colors from the list in the sidebar,
 - **Shaper / Matter: Position Layers** editor,
 - **Matter: Aspect Layers** editor,
 - **Matter: Environment Layers** list in the **Product Environments** editor.
 - **Matter: Overlay Layers** list in the **Overlays** editor,



TIP

Aspect and environment layers are stored at the product level. This means that a given aspect or environment level only affects the product with which it is associated. To apply the rule to several products, add the appropriate target layers for each additional product.



TIP

To ensure the visibility of configurations with overlay layers, the overlay in question must be assigned to a sensor used in the viewport camera. The overlay display must be enabled.



WARNING

You cannot use a given layer as the target for two different rules.

Rule Syntax

Rule syntax is based on the following principles:

- All rules have names.
- All expressions are enclosed in parentheses.
- All rules begin with an operator, followed by an operand.

Simple Rules

Simple rules are expressions using the "defined" operator only. This operator takes a single argument, a user-defined symbol, which follows it. The symbol is set off by a space and must be set inside double quotes.

Simple rules are written as:

- Rule (defined "symbol")
- A symbol can take the form "**partition**" or "**partition.value_n**". In the case of "**partition.value_n**" forms, multiple rules will have the same "**partition.**" prefix.

```
Rule1(defined "partition1")
```

```
Rule2(defined "partition2")
```

```
Rule3(defined "partition3.value_1")
```

```
Rule4 (defined "partition3.value_2")
```

```
Rule5(defined "partition3.value_3")
```

Complex Rules

Complex rules are Boolean expressions. They can call on several of the operators available: the operator "defined" and the logical operators "and", "or", "not", "xor".

Each logical operator takes two arguments in any order. The arguments of the logical operators are expressions enclosed in parentheses and can be either the expression of a simple rule or the expression of another complex rule.

Operators are placed before operands in the Boolean expression. Nested parentheses indicate the grouping of expressions and their order of evaluation.

- This rule is true if symbol_p and symbol_q are defined.

```
Rule(and (defined "symbol_p") (defined "symbol_q"))
```
- This rule is true if symbol_p or symbol_q is defined.

```
Rule(or (defined "symbol_p") (defined "symbol_q"))
```
- This rule is true if symbol_p or symbol_q is defined ("or" is evaluated first), and if symbol_r is also defined.

```
Rule(and (or (defined "symbol_p") (defined "symbol_q")) (defined "symbol_r"))
```



TIP

Refer to the [Creating Complex Rules \[426\]](#) chapter for more information.

Example: Creating Configuration Rules



NOTE

This example of configuration rule creation for the color of a truck cabin is based on the database **toy_truck_tuto.p3d**. You can [download it here](#).

First, aspect layers need to be created for the configurable elements.

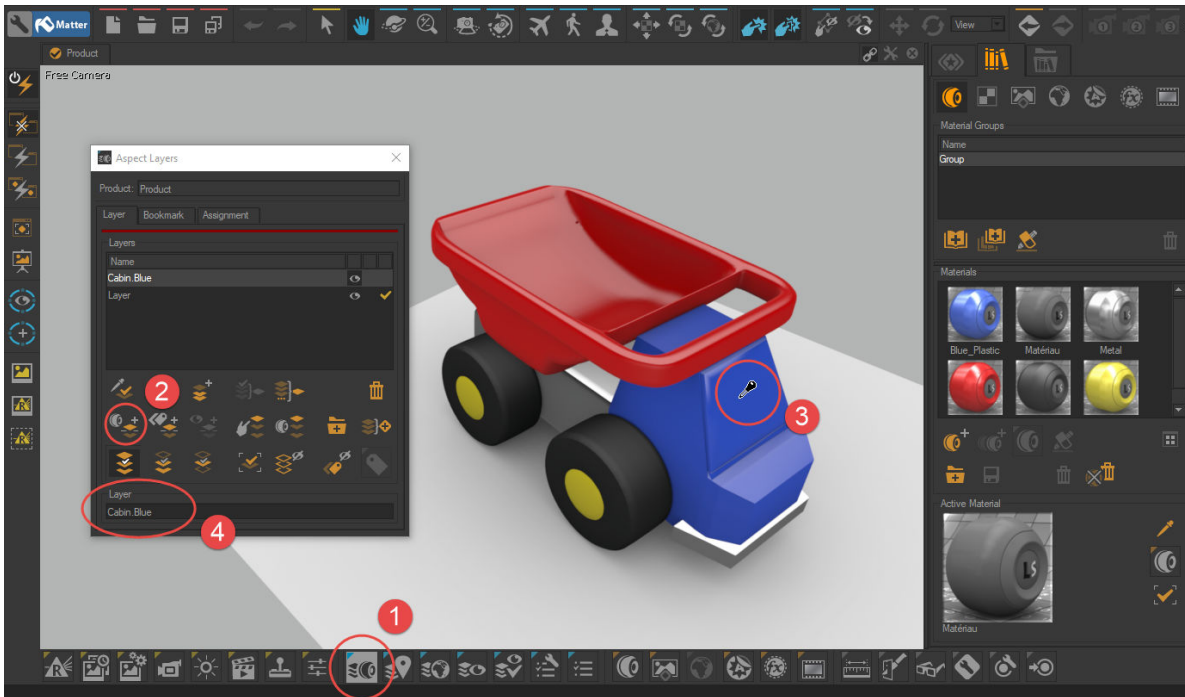

1. In **Matter**, open the **Aspect Layers** window by clicking on this icon  at bottom of the interface.
2. Select the **Split by picked material** tool.
3. Click on an element linked to the configuration to create an aspect layer.
4. Rename the aspect layer created by following the naming principle: "**partition.value**" (for example: **Cabin.Blue**).

The use of this naming system lets you automatically create configuration rules (see next paragraph). Using it therefore saves considerable time.

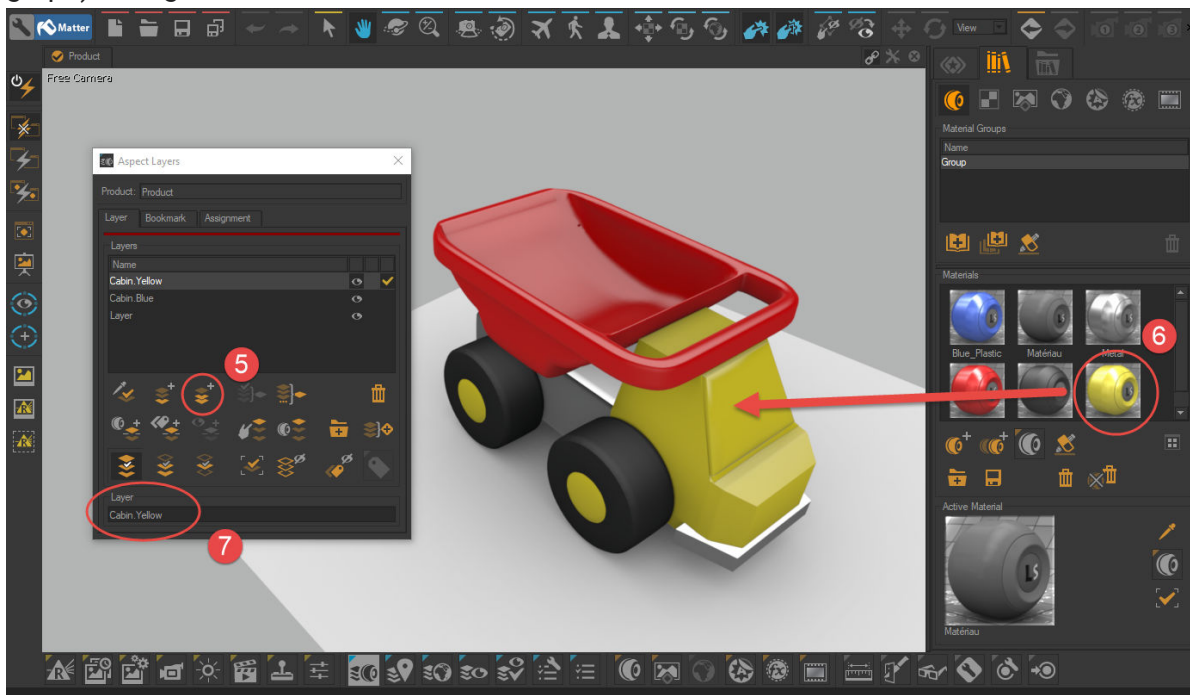

5. Click on the **Duplicate the Aspect Layer** button to create a variant of the element linked to the configuration.

6. Drag-and-drop a new material on the element in order to assign to the aspect layer the new value taken by the element linked to the configuration.
7. Rename the aspect layer according to the newly assigned value (in our example: **Cabin.Yellow**).
 - Create as many variants as necessary by repeating steps 5 to 7.
 - Create new configurable elements by repeating steps 2 to 4, and then create their derivatives by repeating steps 5 to 7.



NOTE

Patchwork 3D also lets you create product derivatives relating to geometry.

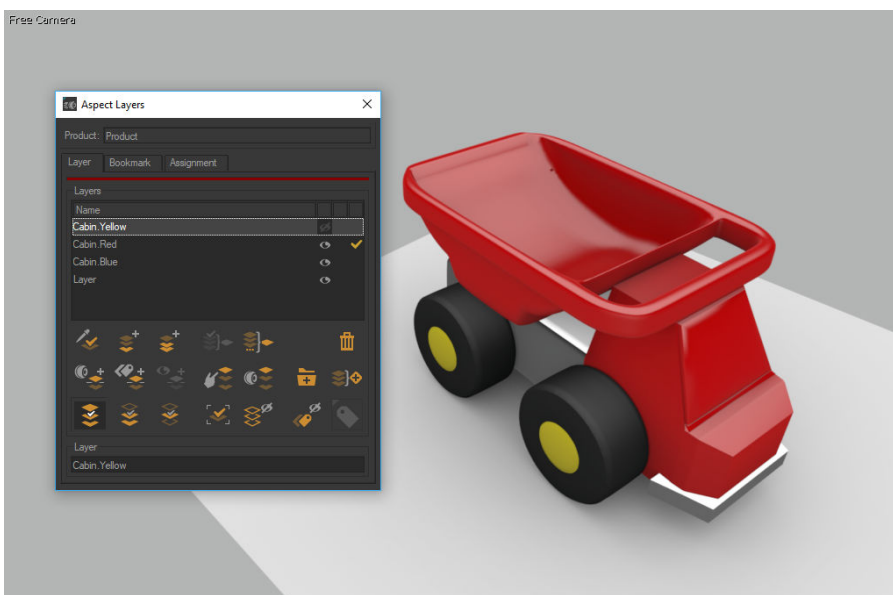
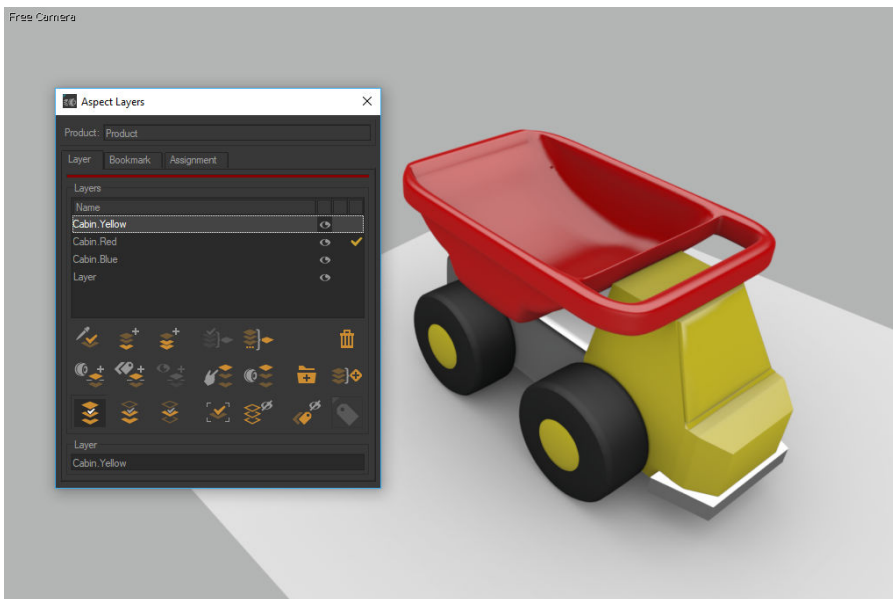

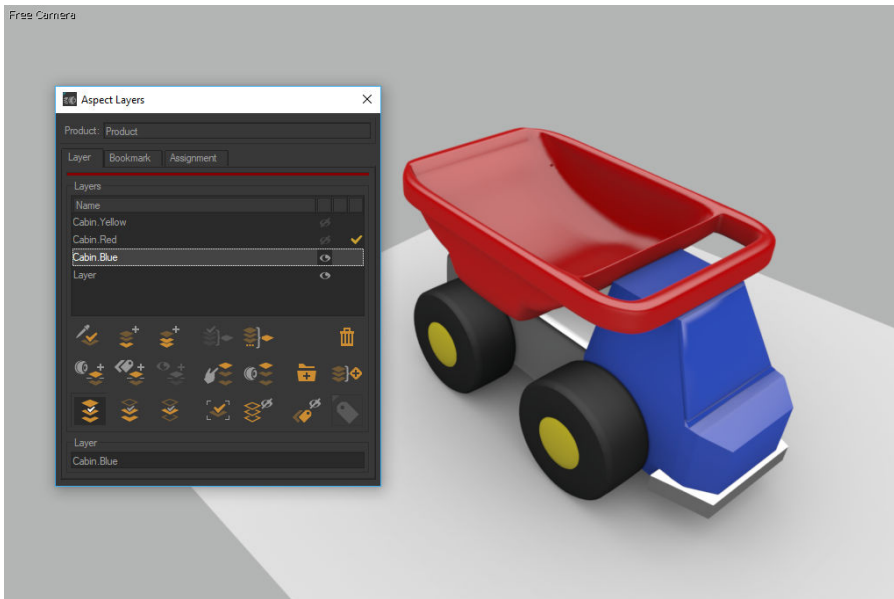

Aspect layers Cabin.Yellow, Cabin.Red and Cabin.Blue.



Click on this icon to show dialog **Configurations**. In the Browser tab, select Yellow in the drop-down list. Name all layers using the same prefix "**Cabin.**", then drag and drop the layer selection into the **Rules** tab of the Configurations editor. The interface builds the following rules:

Cabin.Yellow (defined "Cabin.Yellow")

Cabin.Red (defined "Cabin.Red")

Cabin.Blue (defined "Cabin.Blue")

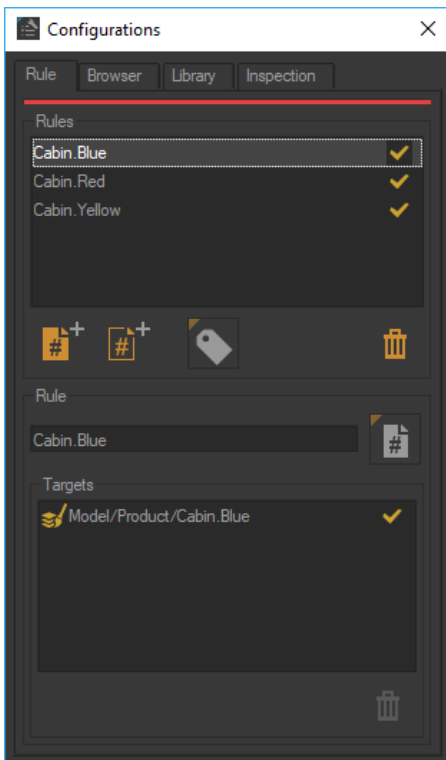

Rule Cabin.Blue determines the visibility of aspect layer Model/Product/Cabin.Blue.

This set of rules follows the principle of exclusion: only one of them is evaluated as true at a time. We check that each of these new rules targets an aspect layer.

This rule set follows the exclusion principle: only one of them is evaluated as true at a time. Each of these new rules targets one aspect layer. Symbols **Cabin.Yellow**, **Cabin.Red** and **Cabin.Blue** are added automatically as a drop-down list to the available symbols in the **Configurations Browser**. Selecting **Yellow** means defining the symbol Cabin.Yellow. Since only one of these symbols can be defined at a time, only one of the new rules is evaluated as true. A partition corresponding to the color of the cabin was created.

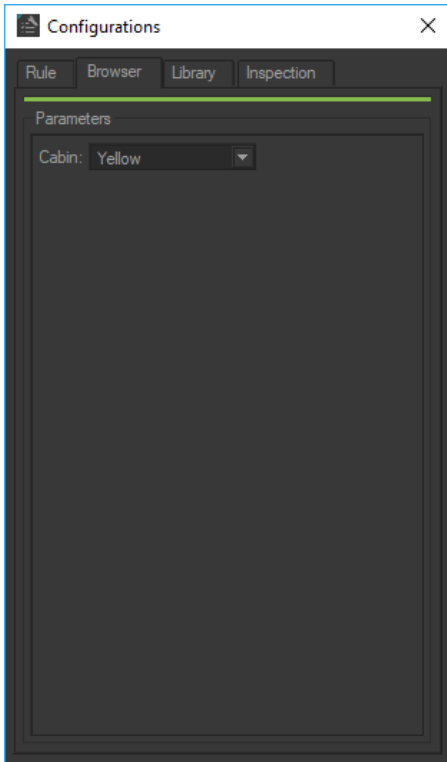

Drop-down list generated automatically from the symbols involved in the new rules.

In the **Browser** tab, select **Yellow** from the drop-down menu. In the **Inspection** tab, the **Cabin.Yellow** rule appears in green because it is true. The aspect layer **Model/Product/Cabin.Yellow** is then visible. The **Cabin.Red** and **Cabin.Blue** rules appear in red because they are false. The target layers of these rules are hidden.

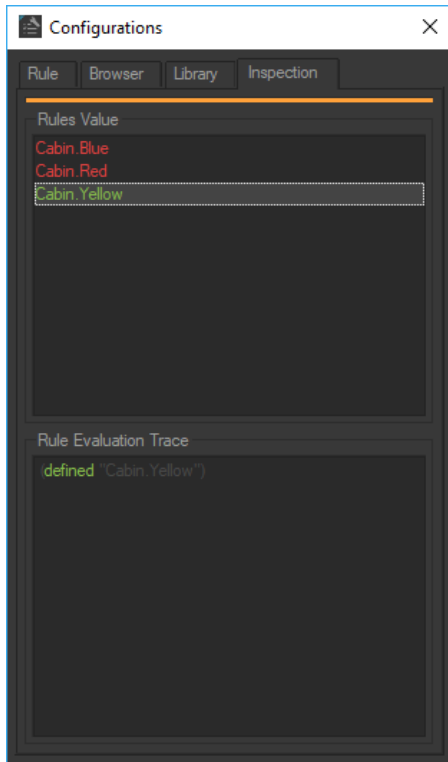

Inspection tab shows the result of rules evaluation.

Create a configuration rule for enabling or disabling the displaying of material on the ground in the same manner. First, create the aspect layer **Model/Product/Ground** corresponding to material assignment on the ground. Generate the rule **Ground** by dragging and dropping the layer from the **Aspect Layers** editor to the **Configurations** editor: the **Simple Rule** editor pops up, allowing for specifying the rule name and the symbol involved.

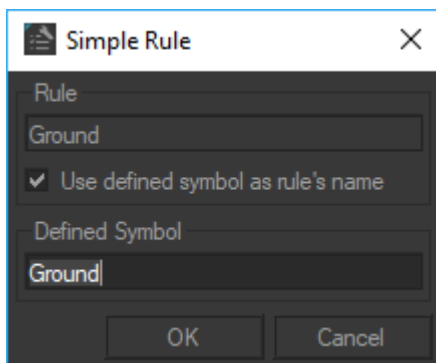

Rule Ground creation using the Simple Rules editor.

The rule "**Ground**" follows the activation/deactivation principle and is written:

```
Ground (defined "Ground")
```

A partition corresponding to the ground was created and a check-box for defining the symbol **Ground** added automatically to the list of available symbols in the **Browser** tab in dialog **Configurations**. Ticking the check-box defines the symbol.

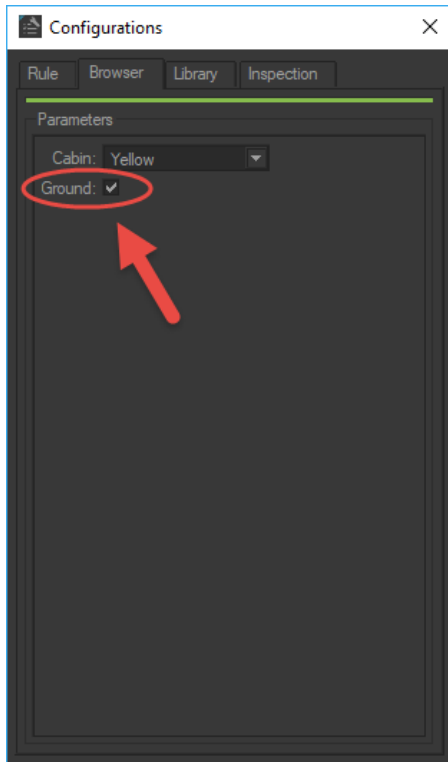

Check-box for defining symbol Ground.

Configuration Annex: Auto-Partitioning

The Concept of Auto-Partitioning Aspect Layers

The geometry, lighting, and position layers belong to the model, whereas the aspect layers belong to the products. As a consequence, aspect partitions defined through configuration also belong to each product and not to the model. They cannot be transferred from one product to another product created from the same model directly.

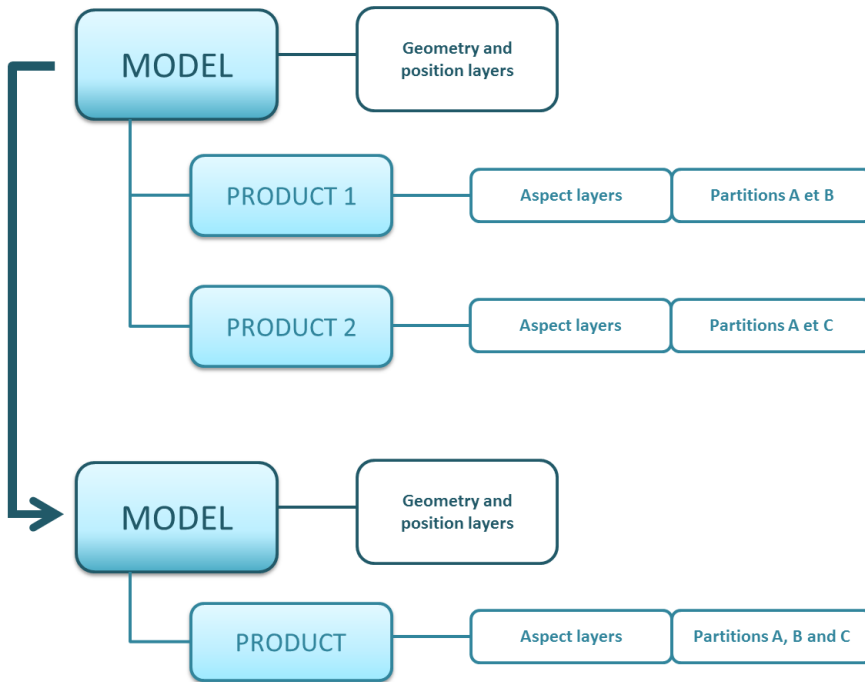

You might find yourself in this situation if you are working on a multi-product database.



Auto partitioning operating principle.

In order to access all product partitions inside a single product, auto-partitioning is required. Auto-partitioning gathers all product partitions related to aspect layers and assigns them to a single product.

To auto-partition a product, use automated functions available in the **Aspect Layers** editor.

1. From the **Matter** module, create a new, blank product.
2. Open the **Aspect Layers** editor. Click on the **Editors** menu > **Aspect Layers**.
3. Click **Import Aspect layers** . This imports all aspect layers into a product.
4. Select all of the imported layers. Click on **Expand Selected Layers Selection by Assignment** . This creates partitions.



TIP

It is best to rename the aspect layers at this point. To simplify this task, you can use the

Replace String function  in the **Aspect Layers** editor.

An example of how to implement auto-partitioning is included below.

Example: Creating a Configured Product with Auto-Partitioning



NOTE

This example of configuration rule creation for the color of a truck cabin is based on the database **toy_truck_tuto.p3d**. You can [download it here](#).

This example uses the database **toy_truck_versions.p3d**. It contains several product versions including a single aspect layer each. The following tutorial explains how to gather all the versions into a single configurable product to create a complete product range.

The product versions available in the database show different colors for the cabin on the one hand and the bin and rims on the other hand. The configured product will then require two configuration rules.

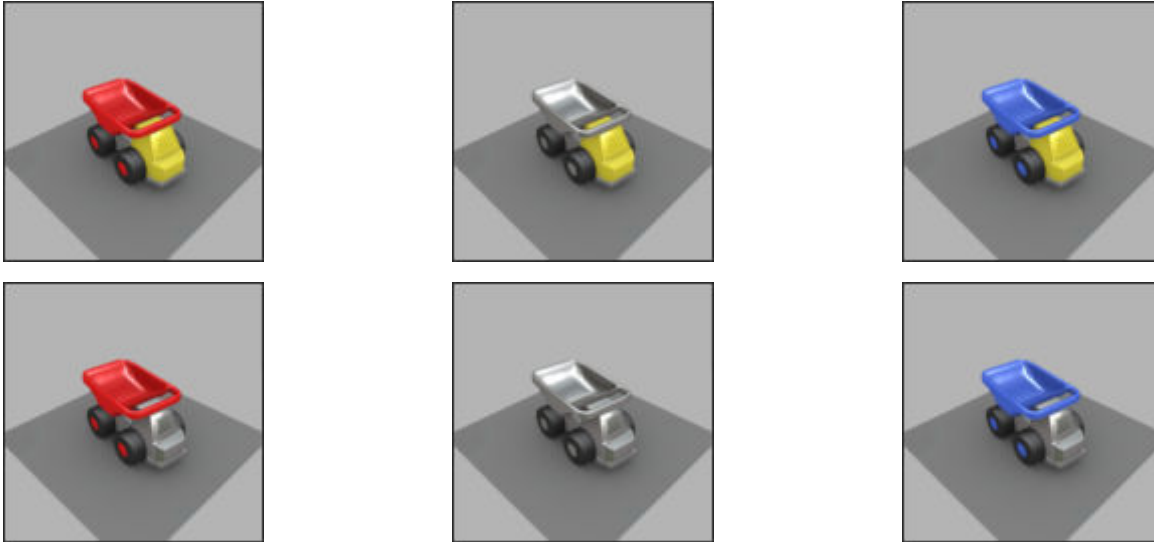

The six product versions created from the same model.

Step 1: Creation of a Blank Product and Layers Import from All Product Versions

Create a new product called **Configured Product**.

Aspect layers belong to the product versions and not to the model. The product created only has a blank base aspect layer. In order to create the configuration system, the aspect layers of the different product

versions must be imported in this product. Use the function **Import Aspect layers**  accessed through the **Aspect Layers** editor to import aspect layers into the new product. The imported layers are displayed in the **Aspect Layers** editor of the **Configured Product** in addition to the base layer.

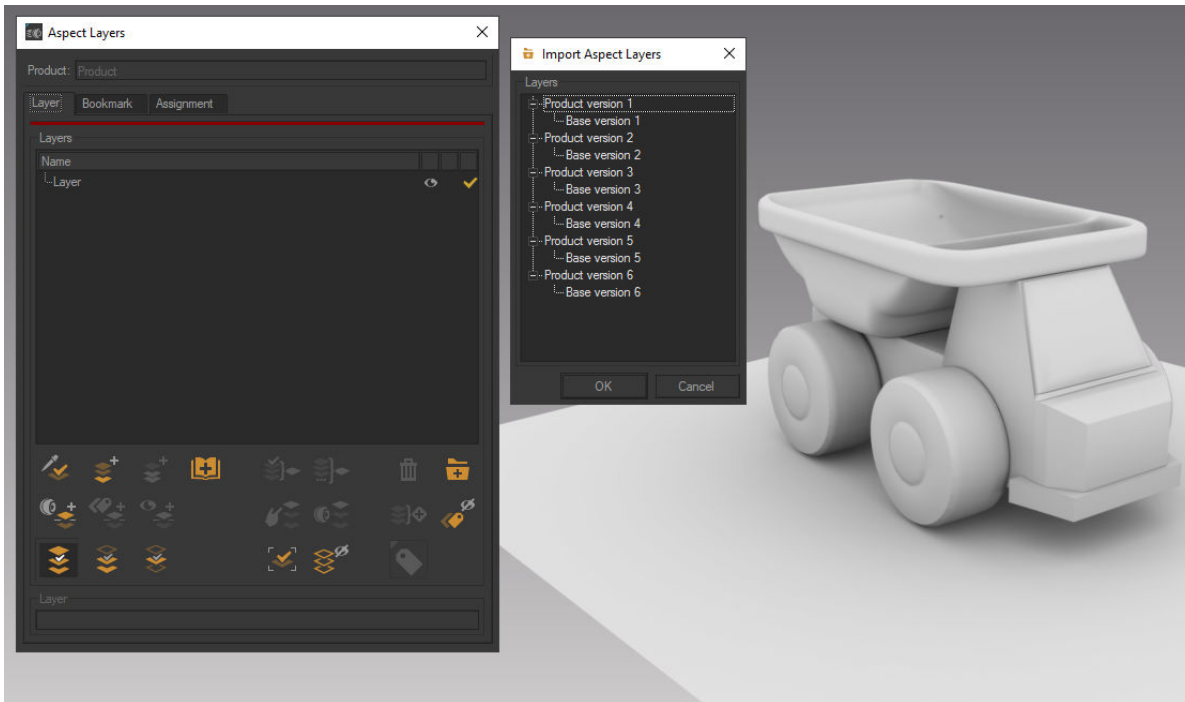

Importing existing aspect layers into the blank product.

Step 2: Auto-Partitioning

Select all imported layers in order to split them by assignment. This operation is performed by using

the **Expand Selected Layer Selection by Assignment** function  from the **Aspect Layers** editor. The partitions obtained are presented below.



Partitions obtained by expanding the layers by assignment.

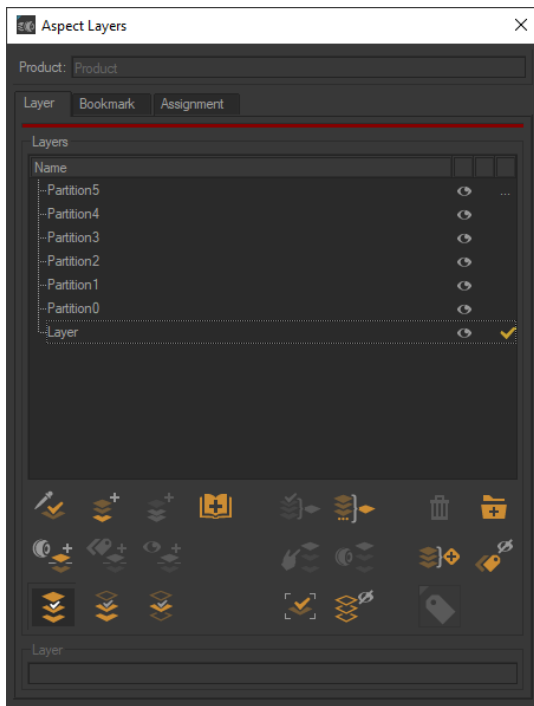

The partitions obtained are listed in Aspect Layers in addition to the base layer of the "Configured Product".

Step 3: Renaming the Layers

Now that partitions have been obtained, configuration rules may be created for the cabin color in one instance and the bin and rims color in the other.

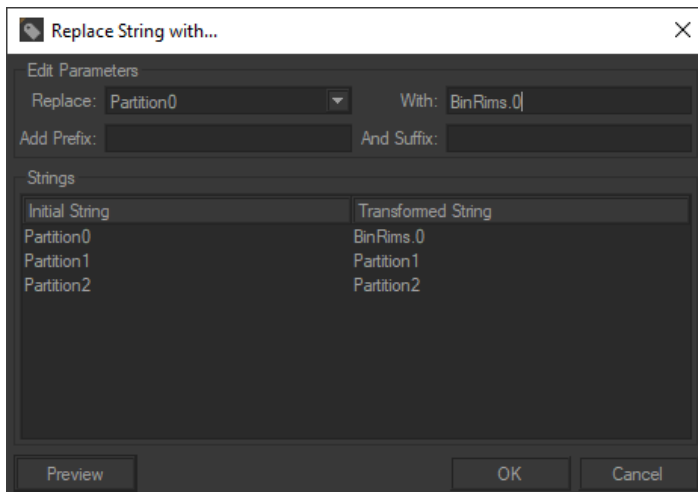

Renaming the layers.

First, rename the layers according to the "partition.value_n" format using the **Replace String** function



of the **Aspect Layers** editor. In this example, rename layers **Partition0**, **Partition1** and **Partition2** into **BinRims.0**, **BinRims.1** and **BinRims.2**. In order to work with explicit names, rename these layers into **BinRims.Blue**, **BinRims.Red** and **BinRims.Silver**. In the same manner, rename layers **Partition3** and **Partition4** into **Cabin.Yellow** and **Cabin.Silver**. Layer **Partition5** is renamed into **Base**. The material assignments in this layer don't require a configuration rule.

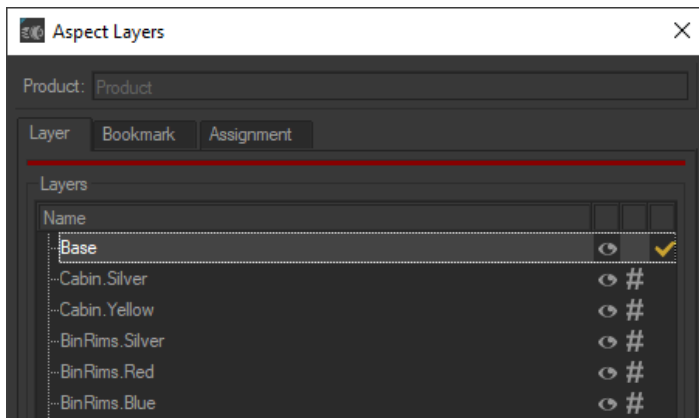

Renamed appearance layers of the product "Configured product".

Step 4: Rule Creation

Create the rules by drag-and-drop of the selection **Cabin.Yellow** and **Cabin.Silver** layers on the one hand, and **BinRims.Silver**, **BinRims.Blue** and **BinRims.Red** on the other hand. The rules created are displayed in the **Configurations** editor. The **Configuration Browser** was also updated.

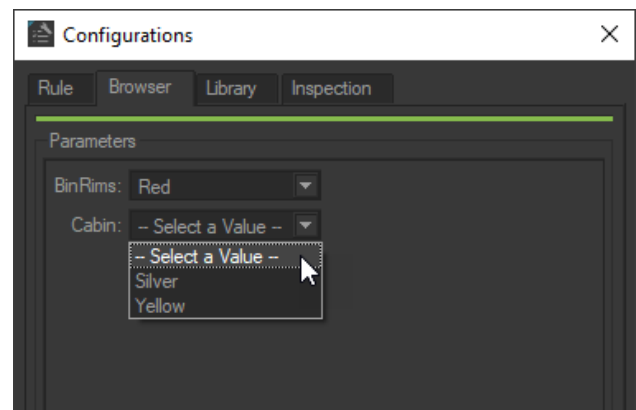
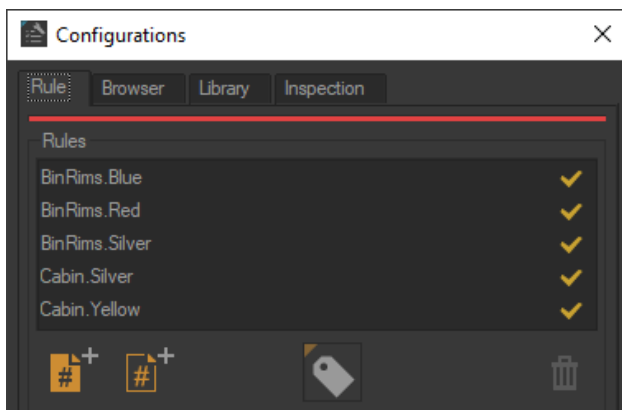

Configuration editor and browser after creating the rules.



TIP

- The different product versions can be deleted.
- In the **Aspect Layers** [143] editor, these product versions are accessible as bookmarks.
- It is possible to create a configuration for each of the corresponding variants in the **Library** of the **Configurations** editor, so that you can easily call it up again for future reference.

CAMERAS

A **camera** is a set of several elements:

- a **sensor**: a set of information concerning the rendering that is applied when the camera is used for viewing. Its modifiable settings include:
 - Sensor size / Aspect ratio,
 - Type of render (post-process, overlays, backgrounds),
 - Type of projection : isometric/perspective ,
- a **lens**: information linked to the position of the object viewed in relation to the camera:
 - Focal distance / Field of view angle (FOVX or FOVY),
 - Depth of field (aperture, focal point distance),
- a **camera position**: the position and the orientation of the camera.

Cameras are used to prepare rendering by setting up a particular view of a product in a viewport. This view can then be saved, recalled, or used to create films and images.

Identifying the Camera Used in a Viewport

The name of the camera that is active in a given viewport is indicated in the upper left corner of that viewport, followed by the name of its sensor, if one is used. In the case of the free camera, if a preset is used, the name of the preset mode is indicated: top, bottom, left, right, front, or back.

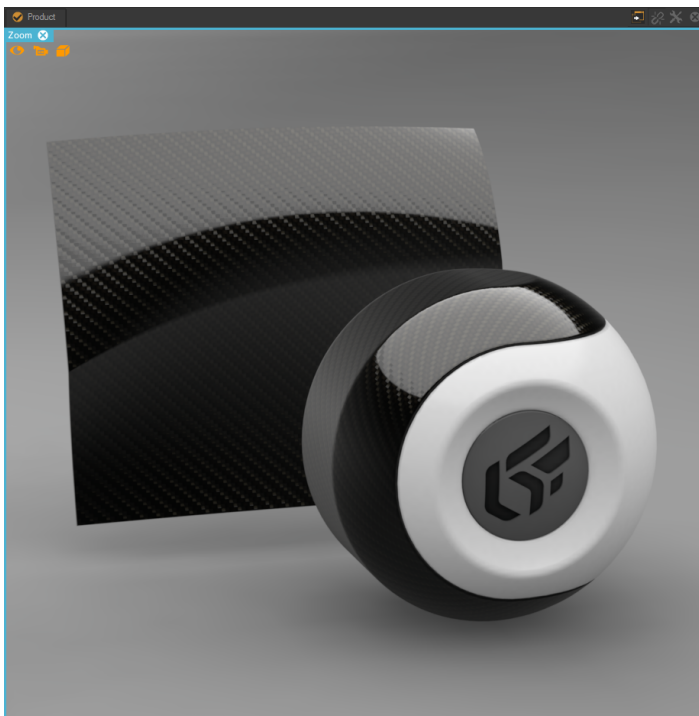

Identifying the camera used in a viewport. In this example, it is the camera named Zoom.

Recalling a Camera's Settings in a Viewport

A camera's settings can be recalled in a viewport. This replaces the current settings of the active camera in that viewport with the settings being recalled. Any of the following actions will recall a camera's settings in the current viewport:

- a click on a camera in the list of the **Cameras** editor;
- a click on the icon  > **Camera View** of the viewport to select a camera view.
- Clicking on one of the **four favorite camera buttons [444]** in the toolbar or using their keyboard shortcuts, if you have assigned favorite cameras for the product in the current viewport.

The position, orientation, sensor effects, and lens properties change instantaneously.

Modifying a Camera's Settings

It is possible to modify the settings of a camera directly from the viewport in **Shaper** or **Matter** or edit them from the editor of cameras.

By directly selecting a camera in the viewport

Assuming that your database has at least one camera in the scene, select it directly in the viewport of **Matter** or from **Shaper** to modify its location in the scene using the translation or rotation gizmos. You can also adjust the camera target in the same way.

To display what the camera frames it is necessary to have at least two distinct viewports, i.e. a viewport attached to a camera listed in the following menu  > **Attach a camera** and a viewport that will be used to manipulate the camera gizmo. A blue frame indicates that the current camera is in edit mode.





NOTE

The way a camera works in edit mode is the same as when attached to the viewport.



NOTE

By default the cameras are hidden in the scene, you can, however, display them from the **Cameras** editor by clicking on this icon  or lock them  in the viewport from the **Cameras Editor [148]**. Refer to the **Cameras [441]** chapter for more details on the overall operation of the cameras.

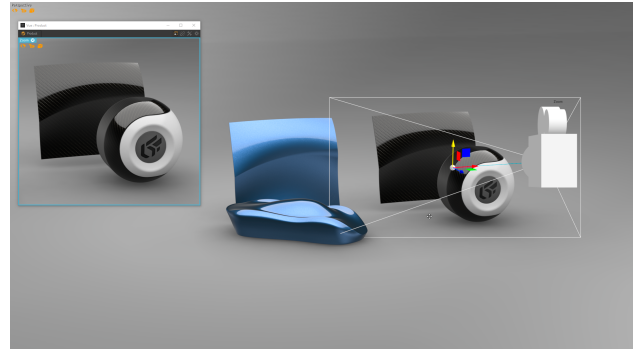
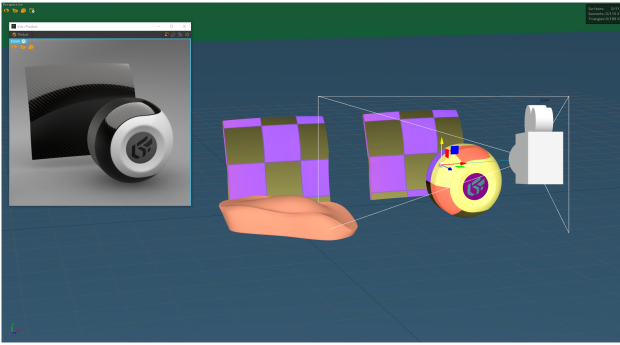

Edit a camera directly in the viewport from **Shaper** (image on the left) or from **Matter** (image on the right) without using the **Cameras editor**.

By selecting a camera from the Cameras list

To modify a camera's settings, the **Edit current camera** mode must be enabled. Enable this mode for the selected camera in the **Cameras** editor by clicking on the  **Edit current camera** button. You can also enable this mode by choosing **Edit camera** from the context menu that opens when you right-click on the camera in the Camera List.

A blue frame indicates the current camera is in editing mode.

The settings shown in the **Cameras** editor are the settings for the active camera in the current viewport. When the camera's settings are displayed on the right of the **Cameras** editor, the viewport shows what is seen by the camera. The name of the camera is indicated in the upper left-hand corner of the viewport.

As you navigate in the world, you modify the camera's position and orientation. To explore the 3D world, you can use the various navigational modes, **Pan**, **Zoom**, **Orbit**, **Fly**, **Walk**, and **Head**, as well as the mouse and keyboard shortcuts assigned to them.

To return to the free camera, disable the **Edit current camera** mode.

Default Camera: the Free Camera

Viewport Free Camera

The free camera exists only in its viewport and is deleted when the viewport is closed. If you have marked a camera as the favorite camera 1 for a product, that camera's settings will be used to initialize the viewport's free camera when the product is loaded.

The free camera's settings can be modified in the **Cameras** editor. They are also edited as you navigate in the viewport.

You can change the sensor used by the free camera by dragging and dropping a new sensor onto the viewport or onto the **Sensor** field in the **Cameras** editor.

Viewport Camera Presets

Each viewport has a series of camera presets: top, bottom, left, right, front and back views.

You can change the preset at any time. Right-click on the name of the active camera, which appears in the top left corner of the viewport. In the contextual menu that appears, select **View**, then choose the camera preset that you would like to activate.

It is not possible to modify these camera presets.

Product Favorite Cameras



Four favorite cameras per product are available via shortcuts in the toolbar.

To mark a camera as a favorite:

1. Use the keyboard shortcuts from the active viewport:
2. Select the favorite camera on which you want to assign the current camera settings from the **Cameras** menu > **Set Favorite Camera**
3. In the **Cameras** editor, select the camera to use as a favorite and click on the corresponding favorite button at the bottom of the editor just below the **Camera list** box.

Shortcut	Function
Ctrl+F9	Use the current camera settings as favorite camera 1.
Ctrl+F10	Use the current camera settings as favorite camera 2.
Ctrl+F11	Use the current camera settings as favorite camera 3.
Ctrl+F12	Use the current camera settings as favorite camera 4.

This creates favorite cameras for the product in the active viewport.

To restore the favorite cameras of a product in a viewport:

1. From the main interface of **Matter**, click on the button corresponding to the favorite camera you would like to restore.
2. Select the favorite camera to be restored from the menu **Camera** > **Restore Favorite Camera**.
3. Use the keyboard shortcuts:

Shortcut	Function
F9	Restore the favorite camera 1 in the viewport.
F10	Restore the favorite camera 2 in the viewport.
F11	Restore the favorite camera 3 in the viewport.
F12	Restore the favorite camera 4 in the viewport.

Generating Bookmarks from a Kam File

Available in: **Matter** : **Editors** menu > **Cameras**

The frames in a *.kam file can be converted to cameras by the **Cameras** editor. To do this, at least one .kam file must already be loaded before you generate bookmarks.

To load a *.kam file:

1. Open **Timelines** under **Matter** > **Editors** menu > **Timelines**.
2. On the right-hand side of the editor, click on the **Camera Animations** library tab. Create a new camera animation using the **New** button below the **Camera Animations** list.
3. In the dialogue box that appears, choose the type **Kam File**. Validate this step.

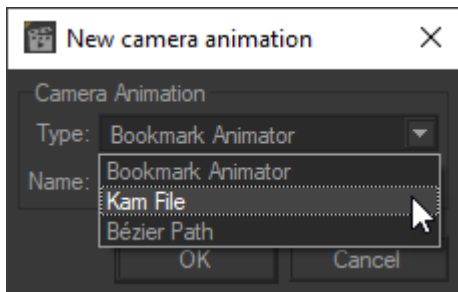

4. Double-click on the name of the animation you have just created. The **Camera Animations** editor will open.
5. In the **Kam Files** zone, click on  **Import a Kam File**. Select your .kam file and validate.
6. You can import several .kam files. You will be able to choose later on which of the open files you want to use to generate bookmarks.

To generate the bookmarks:

1. Open the **Cameras** editor: go to the **Editors** menu > **Cameras**.
2. Select the option  to open a .kam file. The **Import Cameras** window will open. In the first drop-down list, choose **Import from kam file**.
3. In the second drop-down list, choose the group in which the cameras will be placed. By default, the cameras that will be created will be placed at the root of the camera hierarchy. You can choose from among any of the existing camera groups.

4. In the drop-down **Kam file** list, choose the file to use. If you have opened several .kam files, they will all be shown in the drop-down list.

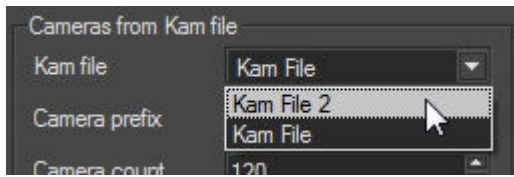

Choosing the .kam file to use.

5. The editor will provide a name for each new camera in the format **<prefix_number>**. By default, it proposes the .kam file name as the prefix. You can change the prefix in the **Camera Prefix** text zone.
6. **Camera count** is the number of cameras to be generated. Each frame of your .kam file can be used to provide a view for a camera. Consequently, you can generate, at most, one camera for each frame. You will manage the offset of the first camera and the frame spacing between cameras in the next steps.
7. By default, the first camera is created from the first frame of the .kam file. If you prefer to change this, use the sliding bar to offset the first camera.



Modifying the offset of the first camera.



NOTE

- **0** offset: the first frame will be used to generate the first camera.
- **N** offset: the frame **N+1** will be used to generate the first camera.

8. Use the **Current camera preview** slider to check each camera to be created. If you are not satisfied with the automatically calculated spacing, you can adjust the frame that will be used to generate each individual camera. Use the **Camera adjustment** tool to move each camera forwards or backwards in the frame sequence.

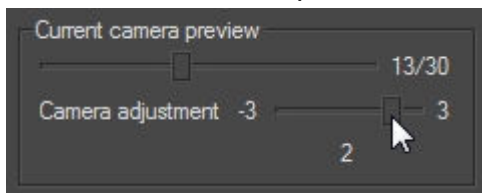

Adjusting a camera within the frame sequence.

9. Once all the settings have been adjusted, click **Import** to begin generating the cameras.

ANIMATION

Animating Geometries

Geometries of models can be animated in Patchwork 3D using the kinematics hierarchy available in *Shaper*.

Nodes, or **parts**, in the hierarchy are animated in one of three ways: freely (by rotation or translation along any of the three principal axes), by rotation along an axis, or by translation along a vector. As part of a hierarchy, child nodes are animated with their parent nodes. This allows you to create functional hierarchies and complex moving parts.

For example, a car door part might rotate along an axis running through its hinges. The range of its rotation is delimited by the angles of its open and closed positions. You might also have a child part for the car window, which is a constituent part of the door but which can also be raised and lowered independently of the door's position. In this example, when the door is opened, the entire door, including the window at its current position, moves. This hierarchical configuration allows you to animate both parts of your model distinctly and simultaneously, though the position and orientation of one has an influence on the position and orientation of the other.

Each part in the hierarchy consists of two elements:

- A null object, a translation vector or a rotation axis for which animation parameters are defined.
- A group of *Shaper* objects associated with the part, to be animated according to the animation parameters of the null, the vector or the axis with which they are associated.

Animating the geometry of your model begins in *Shaper*:

1. To animate the geometry of your model, you will first need to define a functional kinematics hierarchy of parts for your model. This can be accomplished in the **Kinematics** [292] tab of the *Shaper* sidebar. At this stage, you will indicate what type of motion is necessary for each functional part: will it be freely transformed, will it rotate around an axis or will it move along a vector?
2. For each part, you will need to **set the properties that define how it is supposed to behave when animated** [448]. You define the degrees of rotation and the translation distance for each part. You also have precise control over the position and orientation of the null object, the axis of rotation, or the translation vector along which the part will be animated.
3. **A group of surfaces must be selected and assigned to the part** [295] as children.

It is also possible to link animated changes to the position and orientation of a part or a surface to those of another part or surface using the **animation constraints** [296] available in the **Kinematics** [292] tab.

Once the animation has been added in *Shaper*, the *Matter* tools allowing you to visualize this animation on a product will be available. You can:

- Review moving parts using **Animation Sliders** [175] ,
- **Add moving parts to a timeline** [141] using channel animations for real-time playback, use in **Live** [456] mode, or for generating videos.

Animation Utility Objects

The movement of an animated group of surfaces is defined using one of the three utility objects: nulls, rotation axes, or translation vectors.

Nulls, rotation axes and translation vectors possess representations to help you to visualize them and to position them in the 3D space.

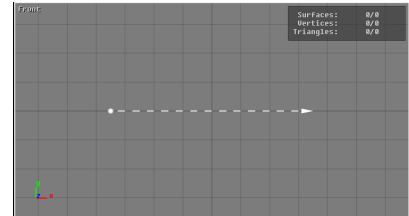
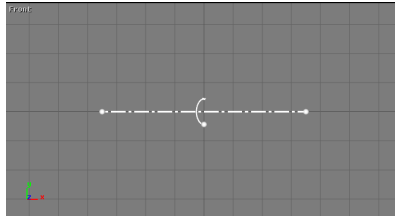
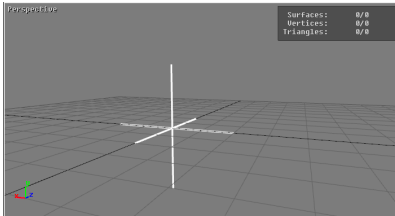

NOTE



The mode , enabled by default, allows objects such as surfaces to be transformed when their parents are transformed. Deselect this mode in order to reposition objects that are already part of a parent-child relationship. This will prevent objects such as surfaces associated with a part from being moved when you reposition the representation of the null, axis, or vector.

Null

A null, is an empty object, invisible in the final rendering, that groups together object that can be affected by a free transformation. A free transformation is one that is not limited to a single type of transformation (rotation or translation), nor is the transformation limited to a single axis or direction in the 3D world.

In the **Shaper** interface, a null is represented by an intersection of axes.

A null object can be selected by clicking on it. The rotation and translation gizmos position and orient it in the world.

Rotation Axis

The rotation axis is a visual representation of the axis around which an animated group of surfaces will turn. To modify the position and orientation of this axis, you will manipulate the representation.

The rotation axis can be selected at one of three points that allow it to be manipulated: its center, and its two endpoints. When it is selected at an endpoint, only that endpoint is moved during a translation to position the axis. This will change the orientation of the axis. If it is selected at its central point, both endpoints are moved during a translation. As a result, the entire axis is repositioned.

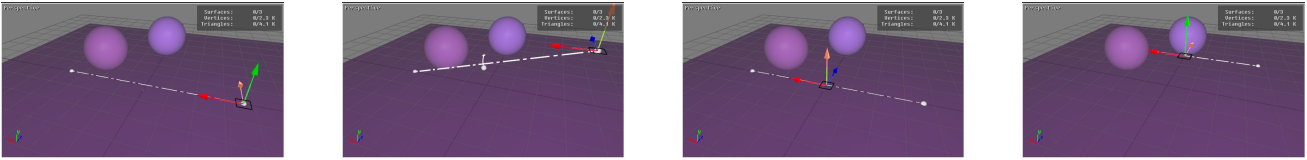

Before (left) and after (right) adjusting the placement of a rotation axis. The top diagram illustrates selection at an endpoint; the bottom diagram illustrates selection at the central point.

Translation Vector

The translation vector is a visual representation of the line along which an animated group of surfaces will move. To modify the position and orientation of this line, you will manipulate the representation.

The translation vector can be selected at one of three points that allow it to be manipulated: its center, and its endpoints. When it is selected at an endpoint, only that endpoint will be repositioned, which will change the direction of the vector. If it is selected at its central point, both endpoints are moved when the position is modified. This results in the entire vector being moved.

Timelines

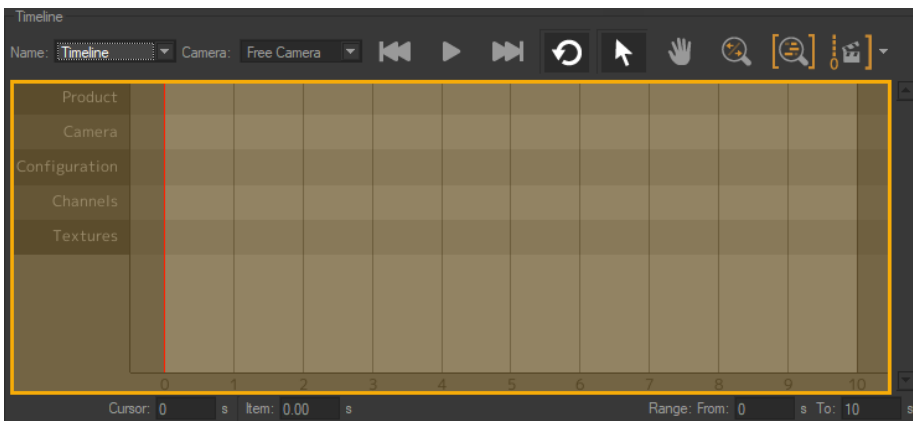

A timeline is a set of animation tracks. Every new timeline is initialized with tracks for **Products**, **Cameras**, **Configurations**, **Channels**, and **Textures**. Each track accepts a given type of animation keys or clips, which are available in the libraries on the right-hand side of the editor. You will find more information about the editor in the corresponding chapter: [Timelines \(Editor\) \[135\]](#).

Tracks accepting channel animation clips and video textures are added below the existing tracks. To simplify creating and deleting additional tracks, the following strategy is applied:

- There will always be one empty track of each kind: if a clip is inserted into the last empty track, a new one is created at the bottom of the list of tracks.
- Only one track of each type is empty: if a track no longer contains any clips, and if another empty track already exists, the newly empty track is deleted.

A slider allows you to scroll through the tracks if the window is not big enough to display them all.

Items in Tracks: Clips and Keys

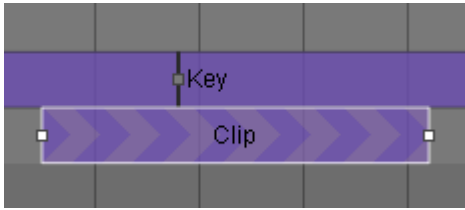

Add clips and keys to the timeline by dragging them from their library tab and dropping them onto their corresponding track.

- **Keys** impose an instantaneous state change. They are positioned at a given point in time. Drop them at the time at which the change should occur.

To help you identify the elements you have loaded, the stretch of time during which the key is active is assigned a solid color and the name of the key is shown. Each key is activated at its position in time and continues to be active until it is replaced by a different key.



NOTE

In a key track, the absence of a key at the beginning of the timeline range is handled differently depending on the type of key.

See the sections on the types of keys ([Product Keys \[139\]](#) and [Configuration Keys \[140\]](#)) for more information.

- **Clips** are sequences of changes over a defined period of time. Drop them at the time when the sequence should begin.

To help you identify the animations you have loaded, each clip is assigned a striped color, and the name of the animation is shown within the clip on the timeline. The length of the clip is a visual representation of the time required to play it. If your clips overlap, the clip that begins first will play until the beginning of the next clip, which will then play instead. The clip that begins last will always have priority.

Some clips contain keys that mark points within the clip. This is the case with bookmarks in a camera animation clip and key frames in channel animation clips. You can reposition a key within a clip. First, select the clip. Then, click on the key and drag it to a new position within the clip.

Once added to a timeline track, items can be:

- Selected,
- Repositioned,
- Removed: Pressing the **Delete** key removes the selection from the timeline.

Selecting Individual Items

Select a single item in any track by clicking on it.

If only one item is selected, its information will be shown and can be edited if the corresponding editor is already open.

To clear a selection, click on an empty area in the tracks.

Selecting Multiple Items

Select multiple items by holding down the left mouse button and dragging to create a selection zone. This zone will select the keys whose central point lies within the zone as well as the clips that are entirely enclosed by the zone.



Using a selection zone to select multiple items.

You can also select multiple items by holding down the **Ctrl** key and clicking on the items in the tracks that you wish to include in your selection.

While the **Ctrl** key is held down:

- Dragging to create a selection zone will add items in that zone to the current selection,
- Clicking on an item that is already part of your selection will remove it from the selection.

To clear a selection, click on an empty area in the tracks.

Repositioning Items

To reposition an item or group of items already in a timeline track, begin by selecting the item or group. Then:

- enter the start time in the **Item** field,
- drag and drop the selection within its track or, in the case of channel animation clips, onto another channel track.

In the case of a multi-item selection, entering a value on the **Item** time zone will align the activation of all of the selected items at the new time value.

A magnet effect allows you snap both keys and clips to the beginning and the end of the timeline range. This magnetism also helps you to position clips one after another with no pause in between. Additionally, you can use it to align the activation times of elements in one track with elements in other tracks.

Resizing Clips



To change the duration of a clip, position the mouse over the left or the right end of the clip. Click and drag the end; this will change the length of the clip.

Resizing a texture clip has no effect on its playback speed. The video will be stopped before its end, or its playback will be looped in order to fit the length of time established by the size of the clip.

You cannot resize selections of multiple clips at once.

Loop, Reverse, and Delete Elements

A right-click on a selected timeline key or clip in a track, or on a selection containing one or more elements, opens a menu from which the following actions are accessible:

-  **Erase** the selection (keys and clips) from the track,
-  **Reverse the playback** (clips only, excluding texture clips),





TIP

The background chevron shading indicates the playback direction of a clip. The chevrons point to the right when the clip is played forwards. When the playback direction is reversed, the chevrons point to the left.

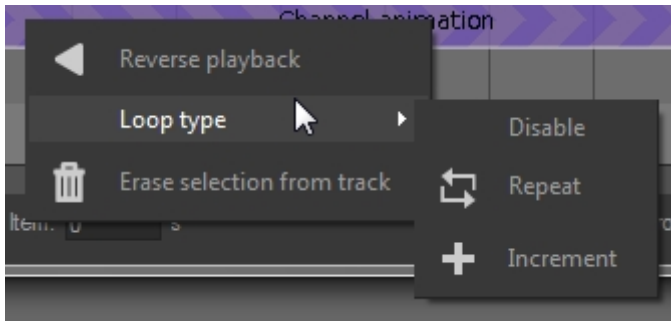
- Loop the playback of the selected clips (excluding texture clips) by selecting the **type of loop**:



-  **Repeat**: This mode repeats individual clips an infinite number of times. At the beginning of each repetition, the values that have been modified are reset to their initial value, and the animation is replayed identically. A clip that rotates an object five degrees will be returned to its initial position and will then move the object the same five degrees again.
-  **Increment**: This mode repeats individual clips an infinite number of times. It is available only for channel animations. Any values that have been modified retain their modification, and each new repetition of the clip adds the new modification to the previous one. A clip that rotates an object five degrees will move it from zero to five degrees on the first repetition, from five to ten on the second, from ten to fifteen on the third, and so on.
- **Disable**: This option removes looped playback for the selected clips.

Bézier Curve Primitives

Available in: **Matter** or **Shaper** via the toolbar:

- **Create Bézier path** 
- **Show Bézier Paths Editor** 

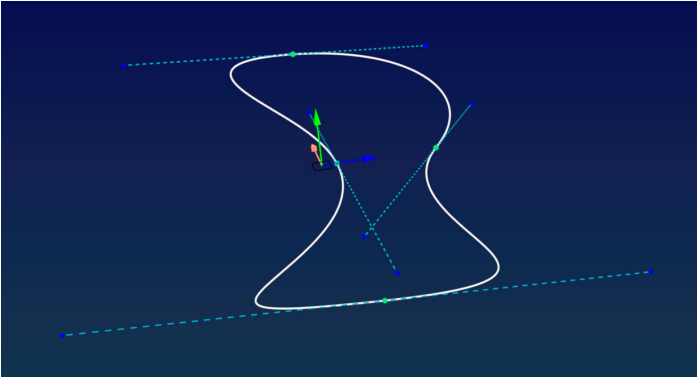

Patchwork 3D Bézier curves are supported for camera and camera target paths in animations. The camera, its target, or both can be animated along any existing curve in your product.



The simplest form of a Bézier curve is a curve calculated between two control points. The shape of the curve is manipulated by modifying the position of the tangents running through these control points. The Bézier curves in Patchwork 3D consist of two or more points, with a curve passing through each pair of points. This chain may have two endpoints (an open curve) or the two ends may meet and join together (a closed curve).

When creating a Bézier curve, you provide the following information:

- The **name** of the curve being created.
- The number of **points** to position along the curve. You can also add or delete points later.
- Whether the curve will be an open or a closed shape. Select **Closed Path** to create a closed curve. This property may be modified later on.

The curve that is created is placed on the grid. An open curve will be placed aligned on the X axis. A closed curve is placed so that its points are positioned equidistantly on an invisible circle centered on the origin in the 3D world.







Modifying a Bézier Curve

You can **Display**  or **Hide**  Bézier curves using the toolbar toggle button. Bézier curves are visible by default.

Modifying a Bézier Curve via the contextual menu

A single click selects the curve. When the curve is selected, the various points and tangents along the curve are displayed.



Right-click on a curve to open the curve's context menu. From this menu you can:









Icon	Function	Description
	Show/Hide Bézier Path	Hides or shows a Bézier path in the 3D Viewport. TIP Process to change simultaneously the state of several Bézier paths. From Bézier Paths Editor , right click on the selection and then click Show/Hide
	Freeze/Unfreeze Bézier Path	Freezes or unfreezes the selected Bézier Path from editing. TIP Process to change simultaneously the state of several Bézier paths. From Bézier Paths Editor , right click on the selection and then click Freeze/Unfreeze
	Insert point	Insert a point on the curve at the location you right-clicked.
	Delete the curve	Deletes Bézier Path(s).
	Close/Open a path	Change the path's shape by deciding to Close path or Open path .
	Place start here	Set the start point for animations along this curve.
	Reverse path direction	Reverse the direction of animations on this curve.

A point can also be added to the curve by **Alt**+clicking on the place on the curve where you wish to add a new vertex. An existing point can be deleted by right-clicking on it and choosing  **Delete point** from the context menu.

Modifying a Bézier Curve via the editor

From the **Bézier Paths Editor**, you can:

Icon	Function	Action
	Show Bézier Path	Freezes or unfreezes the selected Bézier Path from editing. TIP Process to change simultaneously the state of several Bézier paths. From Bézier Paths Editor, right click on the selection and then click Show/Hide
	Hide Bézier Path	

Icon	Function	Action
	Freeze Bézier Path	Freezes or unfreezes the selected Bézier Path.
<div style="background-color: #e0f2f1; padding: 10px; border: 1px solid #ccc;">  <p>TIP Process to change simultaneously the state of several Bézier paths. From Bézier Paths Editor, right click on the selection and then click Freeze/Unfreeze</p> </div>		
	Unfreeze Bézier Path	
	Add a path	Adds a path a Bézier path into the 3D Viewport.
	Hide/Show Bézier Paths	Hides or shows Bézier paths in the 3D Viewport.
	Import Bézier Path(s)	Imports one or multiple Bézier paths from the hard drive of your computer.
	Export Bézier Path(s)	Exports one or multiple Bézier paths into the hard drive of your computer.
	Rename Bézier Path	Renames a Bézier path.
	Delete Bézier Path(s)	Deletes one or multiple Bézier paths.

Bézier Curve Position and Orientation

The position and orientation of the curve, as well as those of its points and tangents, can be modified using the translation and rotation gizmos.

- Use the translation or rotation gizmos to manipulate the entire curve if no specific point or tangent is selected.
- When a point is selected, the translation gizmo moves the point in the 3D space; the rotation gizmo changes the orientation of its tangent.

When a tangent's endpoint is selected, the translation gizmo moves the endpoint in the 3D space; the rotation gizmo has no effect.

**TIP**

By holding down the **Ctrl** key of the keyboard you can move the direction point (end of the tangent) regardless of the other direction point.

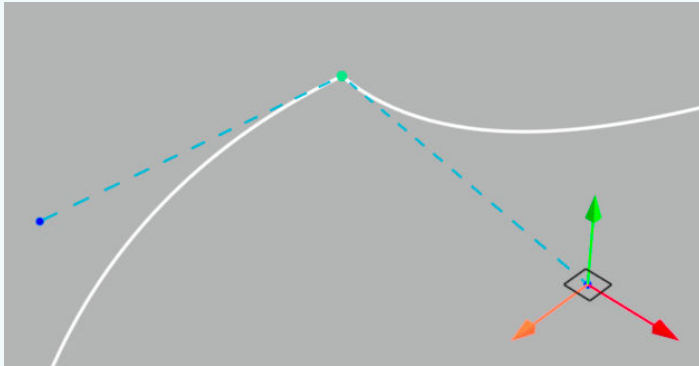
**TIP**

By holding down the **Ctrl + Shift** keys of the keyboard you can change the length of one side of the tangent while keeping the same axis for both sides.

**NOTE**

Multiple points on a single curve can be selected and repositioned at the same time. However, only one curve or only one tangent endpoint may be selected and repositioned at a time.

Live Mode

Live mode is an interactive mode in which you have access both to the navigation modes that allow you to explore your product and its animations and configurations. Animations and configurations can be activated by using triggers, that is, a keystroke or click on a predefined surface.

To make an animation available in Live mode, assign it a trigger in the [Live mode \[197\]](#) editor, then switch to **Live** mode.

When **Live** mode is active, the menus and buttons in the interface are no longer available.

- To leave the **Live** mode, press the **Esc** key.
- Navigate within your scene using the navigation shortcuts.
- Play animations by using the triggers you have defined.

A trigger can be used multiple times while the animation is playing. The playback behavior will depend on the trigger's [play mode \[199\]](#).

Triggers can also be created to cycle through configuration values when a trigger surface is clicked. To create configuration triggers, use the [Tag Manager \[186\]](#) in **Shaper**.

Live mode can be viewed in full screen. To do so, switch the active viewport to full screen (keyboard shortcut: **Y**) before switching to **Live** mode from the editor.



Animating Channels with Advanced Configuration





The **advanced** mode in the **Channels (Editor)** [154] can be used for precise control over one or more channels of animation.





Creating an animation curve using the advanced mode follows these main steps:

1. To the left of the graph, select the curve you wish to edit.
2. Place the time cursor at the time position where you would like to make a change by adding a new key frame.
3. In the active viewport or in the editors associated with the selected channels, make the changes you would like to see at this point in time.
4. Click on  **Capture current values**. This will add a key point in each selected channel, using the values set in the editors and the active view. The new key points are aligned with the time cursor.

You can also add key points by hand: activate the **New key frame**  mode and click on curves on the graph where you would like to place new key frames. Once the key frame has been added, enable one of

the repositioning modes (, , or ) to reposition your key frames interactively by dragging the point with the mouse. If one of these modes is already enabled, you can place a key frame without changing modes by using the function **Alt** + click.

1. By default, the curve which is drawn between two points is of the type **Curve** . In this case, the change in the channel value in this interval of time does not occur at a constant speed. The speed of change of this value on either side of the key point is represented by the angle of tangents to the curve to the left and to the right of the key point. To modify the speed of change, you will need to reposition the tangents. To do so, set the mouse to one of the repositioning modes (, , or ) and click on any key frame to show its left and right tangents.
2. By default, the tangents are horizontal. Clicking and dragging a tangent's end-point modifies the tangent used to calculate the curve. The tangents to the left andR to the right of the key frame are modified independently of one another.

3. To modify the type of progression used between two key frames, open **Key Frames** . Clicking on the option shown next to **Left** or **Right** allows you to modify the progression mode for the curves to the left and to the right of the point, respectively. This opens a list of choices:
- Select **Linear**  to impose a constant (linear) change from the initial value to the final value over the time available between the two points. This appears as a straight line on the curve.
 - Select **Step**  to impose an instantaneous change of value at the key frame's time. This appears as a step (horizontal and vertical lines) on the curve.
 - Leave the **Curve**  form to add ease to the animation slope. Tangents are available at each key frame that has been set to **Curve**. Use them to adjust the shape of the curve.

CLIPPING PLANES

Clipping planes can cut through a model to reveal cross-sections, internal structures, or other details that are usually hidden by outer pieces.

Three customizable clipping planes are available. They can be placed and modified manually, or automated during an animation using a channel animation.

You may be interested in the following topics:

- [Clipping Planes \(Editor\) \[208\]](#)
- [Channels \(Editor\) \[154\]](#)

Animating Clipping Planes

Three types of animation channels exist for clipping planes. These allow you to:

- Enable/Disable the clipping plane
- Position the clipping plane along the X, Y and Z axes
- Orient the normals for the X, Y and Z axes



NOTE

It is strongly recommended that you use all three position or all three normal channels together in the same clip when animating clipping planes.

REAL-TIME SUN

In contrast to the lighting defined in **Shaper**, the real-time sun available in **Matter** provides light that is calculated on a product in real-time. The real-time sun provides light similar to that projected by a sun type light source. The source is not visible. Its beams are infinite and parallel to one another. The source can be positioned in terms that are used to describe the real sun: angle above the horizon, position on a compass, etc.

Data related to the real-time sun is included in databases exported in KDR format.

The real-time sun can be animated using a channel animation.

You may be interested in the following topics:

- [Lighting \[299\]](#)
- [Real-Time Sun \(Editor\) \[235\]](#)
- [Channels \(Editor\) \[154\]](#)

ANTIALIASING

Patchwork 3D includes an antialiasing function for real-time rendering.

Real-time antialiasing can be set up in the **Render Presets** available from the context menu of the 3D viewport.

The effect of the antialiasing is particularly effective in the case of sharp borders and strong contrast between the start and end colors of gradients.

When the point of view changes, artifacts due to high intensities may occur in specular reflections. These artifacts consist in white dots due to highly-localized reflections. Consequently, filtering is deactivated by default during and at the end of interactive phases.

However, as the software antialiasing eliminates the artifacts efficiently and the filtering removes a light blur from the specular reflections, the anisotropic filtering is automatically enabled when the software antialiasing kicks in.

The anisotropic filtering may be set separately for interactive rendering phases, for the end of these phases, and for idle phases. To do so, activate a custom preset in the **Render Quality Settings** of the **Render Presets** submenu of the viewport context menu. Use the **Specular anisotropic filtering** slider to set the level of filtering.

ENHANCED TRANSPARENCY

Enhanced transparency provides improved rendering for transparent surfaces. Rather than using surfaces' bounding boxes to determine their distance from the viewpoint, enhanced transparency utilizes pixel-by-pixel analysis to determine the order in which the surfaces must be rendered.

Using enhanced transparency increases the consumption of GPU memory and reduces the number of images per second. This option is disabled by default.



NOTE

The option Enhanced transparency is not compatible with the use of transparent mirrors. When enhanced transparency is enabled, transparent mirrors are treated as simple transparent surfaces.

Enabling Enhanced Transparency



Use the  button in the **Matter** toolbar to enable or disable enhanced transparency.

Standard versus Enhanced Transparency

This technique for calculating transparency can be costly. In order to improve the rendering of transparency without resorting to enhanced transparency, avoid grouping transparent surfaces together in **Shaper**. A group is treated as a single surface, which can prevent Patchwork 3D from correctly analyzing which geometric elements should be visible through a transparent surface.

	Standard Transparency	Enhanced Transparency
Affected materials	<ul style="list-style-type: none"> Standard materials with alpha, Standard materials of the transparent filter class, Multilayer materials with no diffuse layer, Mirror materials with transparency. 	<ul style="list-style-type: none"> Standard materials with alpha, Standard materials of the transparent filter class, Multilayer materials with no diffuse layer, Mirror materials with transparency (treated as standard materials of the transparent filter class).
Calculation method	Handled surface-by-surface, using the position of the bounding box to determine the order of surfaces from a given point of view.	Handled pixel-by-pixel, analyzing all of the surfaces present at each pixel from a given point of view.

	Standard Transparency	Enhanced Transparency
Advantages	Renders quickly and is suited to most uses of transparency.	Prevents situations where the position of the bounding box is not enough to determine the order of surfaces from the point of view. This can occur with complex transparent surfaces, intersecting transparent surfaces, transparent surfaces that surround other surfaces...

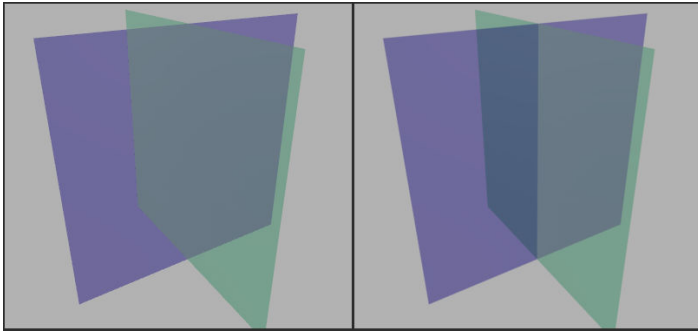

Intersecting transparent surfaces rendered with standard transparency (left) and enhanced transparency (right).

RAYTRACING

The raytracing engine is directly accessible from Patchwork 3D , which makes it particularly easy to use. Each rendered view can be saved in the database, making further operations like applying a post-process easier.

The raytracing engine uses the Patchwork 3D materials from the current product. The render of the materials with the raytracing engine remains true to the one calculated with the Patchwork 3D OpenGL rendering engine. Product views are prepared with the tools available in the Patchwork 3D **Matter** interface. The default environment can be replaced by any environment.

Ray tracing a View

Available in: **Matter** : left side toolbar of the 3D Patchwork interface 





TIP

The default rendering engine selected in Patchwork 3D is the **Path tracing**.

From the **Raytracing Settings**  editor in the left-side toolbar of the Patchwork 3D interface, you can switch between the **Ray tracing** and **Path tracing** rendering engines at any time, even during rendering.

In this chapter, you will find [Raytracing Settings \(Editor\) \[204\]](#) the information related to the settings of the two rendering engines.



Ray tracing a view

To perform ray-traced rendering of the view, use the button **Enable GPU Ray Tracing rendering**  from the side toolbar located on the left side of the Patchwork 3D interface, OR directly in the **Raytracing Settings** editor. Click again  to stop the rendering.



On the left view, a rendering without the **Ray tracing** engine. To the right, a rendering with the **Ray tracing** engine.

Path tracing a view

To perform ray-traced rendering of the view, use the button **Enable GPU Ray Tracing rendering**  from the side toolbar located on the left side of the Patchwork 3D interface, OR directly in the **Raytracing Settings** editor. Click again  to stop the rendering.



On the left view, a rendering without the **Path tracing**. On the right, a rendering with the **Path tracing** with **Global illumination** activated.



TIP

To maintain a natural look with the denoiser, leave enough samples/path traces before activating the denoiser to avoid smoothing too early.

Creating Snapshots using the Ray tracing engine

Available in: **Matter: Snapshot > Snapshot Image / Snapshot Videos / Snapshot Cubic VR Objects / Snapshot Cubic VR Panoramas**

The following types of snapshots may be created using the raytracing engine:

- Image snapshots,
- Video snapshots,
- VR object captures,
- Cubic VR panorama snapshots.



The **Rendering Engine** box of the Snapshot editors.

Below is an example of capturing the Speedster with both renderers: **Ray tracing** and **Path tracing**.



OpenGL snapshot



Ray tracing Snapshot



Path tracing with Denoiser, and Global Illumination

When you create a snapshot, select the proper engine in the **Rendering Engine** box of the snapshot editor. Rendering is started by clicking the **Render** button at the bottom of the editor. Alternatively, it can be postponed for later with the **Snapshot Batcher**. In that case, use the **Add to Snapshot Batcher** button to save the view and its associated parameters to the Snapshot Batcher. You can also replace the current snapshot in the **Snapshot Batcher** with the new view and its associated parameters by clicking on the **Replace Current Snapshot Batcher** Item button.









For additional information, see:

- [Snapshots \(Editors\) \[160\]](#)
- [Snapshot Batcher \[200\]](#)

RENDERING SNAPSHOTS, VIDEOS, AND 3D ENVIRONMENTS

Snapshot Menu

The **Snapshot** menu provides access to the functions that allow you to export the rendering in the active viewport as media content: videos, images, or 3D virtual reality objects or panoramas. It contains the following menu items:

Icon	Tool	Description
	Snapshot Image	Opens the Snapshot Images editor to access the settings and render a view of a product that will be saved as an image file. See: Snapshots (Editors) [160] .
	Snapshot Video	Opens the Videos editor. This editor generates animations or sequences of images based on an initial point of view and a predefined animation. See: Snapshots (Editors) [160] .
	Snapshot Panorama	Opens the Panoramas editor to modify the settings and generate a panoramic 360-degree video. See: Snapshots (Editors) [160] .
	Snapshot VR Object	Opens the VR Objects editor to modify the settings and generate a VR object. See: Snapshots (Editors) [160] .
	Snapshot Cubic VR Panorama	Opens the Cubic VR Panoramas editor to modify the settings and generate a cubic VR panorama. See: Snapshots (Editors) [160] .
	Quick Snapshot	Creates snapshot of the current active viewport. The snapshot is generated by the editor that was most recently used, and the settings of the last snapshot rendered are applied. If no snapshot has been created before, the Snapshot Images editor and its default settings are used.
	Show Info	Enables or disables the Show Info option in any of the snapshot editors. This option displays, along the bottom of the active viewport, a summary of the snapshot dimension settings.
	Snapshot Batcher	Opens the Snapshot Batcher . Use this tool to group snapshots and render them as a batch at the time of your choosing. See: Snapshot Batcher [200] .

PRINTING

Printing Patchwork 3D's printing functionality is used to print the image displayed in a **Matter** viewport on paper or to a digital file. It is available only if a default printer is defined on the computer.

General Print Window

To print the image displayed in the active viewport, open the print menu  accessible from **File > Print** or with the keyboard shortcut **Ctrl + P**.

The general print window is for selecting the printer to use and adding new printers, as well as defining the **Settings** for the printer and the pages to print.

The **Print in a file** function is for saving the image in PDF format. When printing as a PDF a new window will automatically open.

Printing to a File

The **Configure Printers** button recalls the general print window.

When **Print file information** is enabled, the file information in the box is added under images in the *.pdf file generated.

The image **position** on the page is selected by using options **Center**, **Top Left** and **Custom**, for which the margins' width is entered in the fields.

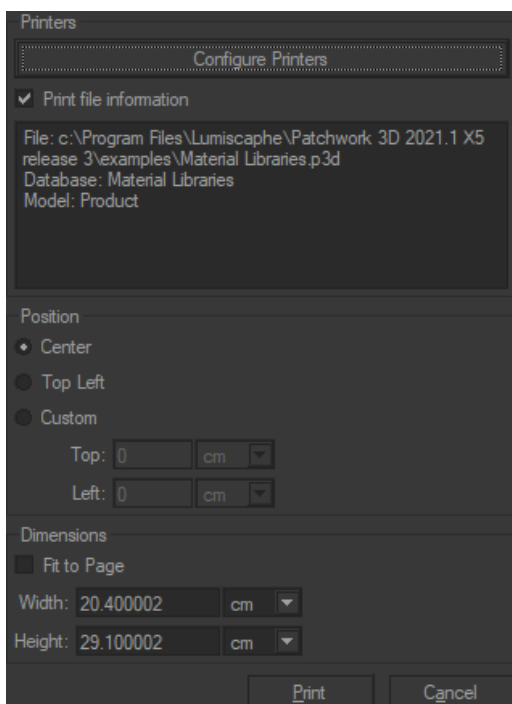

Print in a file window.

The **Dimensions** box contains the image dimension options:

- **Fit Page,**
- Specification of image **Width** and **Height** in the fields and unit selection. The images printed from the **Matter** viewport are considered vector images and will be rendered with the ideal resolution for the required printing dimensions. The renders with raytracing are fixed and will be resized for printing.

SCRIPTING

Available in: **Shaper** or **Matter: Scripting**

Scripting allows you to automate repetitive tasks or to extend the functionalities of Patchwork 3D.

Three operating modes are available:

- The **Console** mode to execute commands interactively. For assistance click the **Documentation** button.



TIP

At any time you can **Interrupt Execution** of the command by clicking on the dedicated button and restart the Python interpreter.

- The **Execute** script mode to execute a .py script stored on your computer.
- The **Start scripting server** mode to launch a server allowing an external Python interpreter to execute commands in Patchwork 3D. The **Local connections only** parameter disallow remote connections. The **Port** allows you to choose the communication port between the server and the interpreter.

Examples of scripts (see the **Scripts library**) were created to help you use Python scripting with Patchwork 3D. Use these examples to familiarize yourself and create new ones.



TIP

At any time you can see the scripting documentation in **Matter** or **Shaper** by clicking the **Scripting** menu > **Scripting Help...**

Workspaces

Thanks to the workspaces you can reorder the Patchwork 3D user interface toolbars according to your use. Workspaces use Python scripting, so please read the [scripting documentation](#) for more details.

ABOUT

This section brings together general information about the software's publisher, this documentation, and the associated legal notices. Here you will find Lumiscaphe, the company that develops and publishes Patchwork 3D, the reading and presentation conventions used throughout this document, as well as the legal notices and the licenses of the third-party components integrated into the software.

About Lumiscaphe

Lumiscaphe helps to strategically connect the design and engineering worlds with marketing and sales support by developing and publishing innovative hybrid solutions employing the Digital Aspect Mockup (DAM) and photorealistic, real-time 3D rendering.

Lumiscaphe provides 3D visualization solutions built on solid experience in real-time rendering technology. Lumiscaphe's range of specialized products includes online and offline 3D product configurators, applications and content created for the web and for mobile devices, as well as tools for publishing and sharing. For creators, a software development integration kit is also available.

Lumiscaphe's clients are found in the automotive, aerospace and luxury goods industries, as well as in the architecture world and in the product design community.

Founded in Bordeaux in 2001, Lumiscaphe has become an innovative actor on the worldwide technology market. With offices today in Paris, Shanghai and Osaka, Lumiscaphe is proud to provide its solutions to its clients directly or through a network of certified partners.

About This Documentation



NOTE

This documentation describes the interface and the functionalities of Patchwork 3D without distinction of version.

It begins with a presentation of the new features, the hardware requirements, and a short section on how to get started with Patchwork 3D.

This document is organized by topic. It does not need to be read in order, and you do not need to read it from cover to cover unless you want to. Instead, use the search function (**Ctrl+F**), the table of contents, and the index to help you find what you are looking for. The chapter and first sub-heading are always listed at the top of the page so that you will know where you are.

Interface Text

Text in the interface and shortcut keystrokes are written differently so that they will be easy to see. They appear like ***this*** in the text.

Links

You will also see hyperlinks in the text. This is an example of a link to the [New features \[20\]](#). If you are reading on screen-based support, you can click on these links to be taken to the related subject. Likewise, the page numbers in the table of contents and the index are links to the pages they indicate. You can click on them to go directly to that page.

Boxes



NOTICE

Boxes like this one are used to indicate novelties for the current software version.



WARNING

Boxes like this one are used to provide a warning.



NOTE

Boxes like this provide additional information. It may be an associated remark or additional explanation.

You may find this information interesting, but it is not essential for understanding the operation or interface being described.



TIP

Boxes like this one give a tip to help you with a better understanding of the concept or with the functionality concerned.

Step-by-Step Instructions

When step-by-step instructions are given, they are formatted as a numbered list:

1. This is the first step.
2. This is the second step.
3. This is the final step.

Images of the Interface

Unless otherwise indicated, all images in this text use the default interface theme, **Dark**. If you are using a different interface theme, the colors on your screen will be different. However, the windows, the interface text, and the symbols on the icons remain the same no matter what theme you choose.